

Suprema

Features

- ◆ 7" user-friendly touch screen control panel
- ◆ Interchangeable hard dough & fluid pump heads
- ◆ Variable speed dosing motor
- ◆ Adjustable nozzle rotation speed
- ◆ Bidirectional advancement of the trays allows you to feed trays from the front or back
- ◆ Adjustable anti-dropping device for cleaner deposits
- ◆ Automatic starting controls
- ◆ Easy to clean quickly and thoroughly
- ◆ Wide range of nozzles and moulds available
- ◆ Optional fluid pump for soft dough and batters
- ◆ Output capacity ranging from 175 to 225 lbs/hr
- ◆ Voltage: 220V/60Hz/1ph/7A



The Ultimate Cookie Depositing System

The new **SUPREMA Cookie Depositor** is designed to be the most versatile wire-cutting and dropping machine available today. With an intuitive, easy-to-use touch screen control panel and a 200 recipe memory capacity the **SUPREMA** is capable of producing 180 trays of consistent, high quality cookies per hour. With a large variety of nozzles and moulds available, the **SUPREMA Cookie Depositor** is extremely flexible; ideal for a wide range of pastries, cookies and biscuits. Its combination of cutting-edge technology and superior design will not only save you significant time and money but it's also sure to satisfy even the most discerning baker.

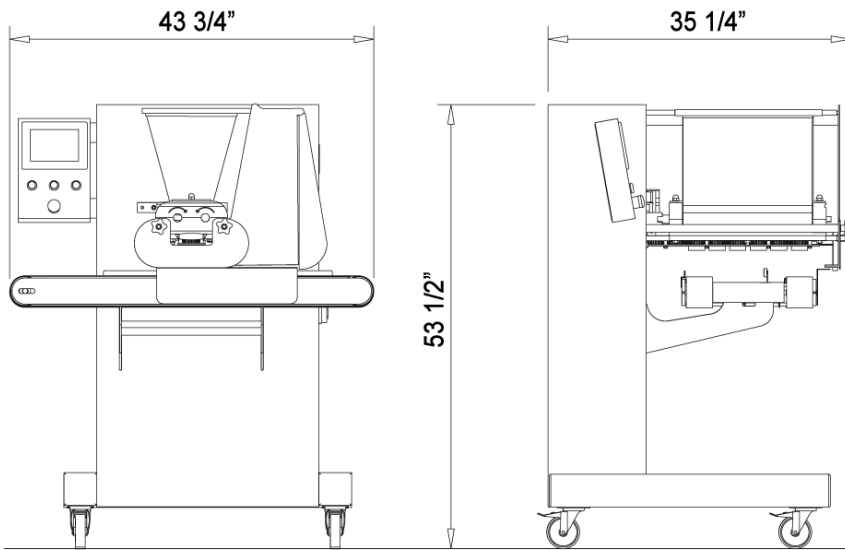

SPECIFICATIONS

Hopper Capacity (Liters)	24
Weight (Lbs.)	529
Power	220V / 1Ph / 7A



The Touch Screen Control Panel is intuitive, functional & very easy to use.

NOTE: Specifications are subject to revision and confirmation.

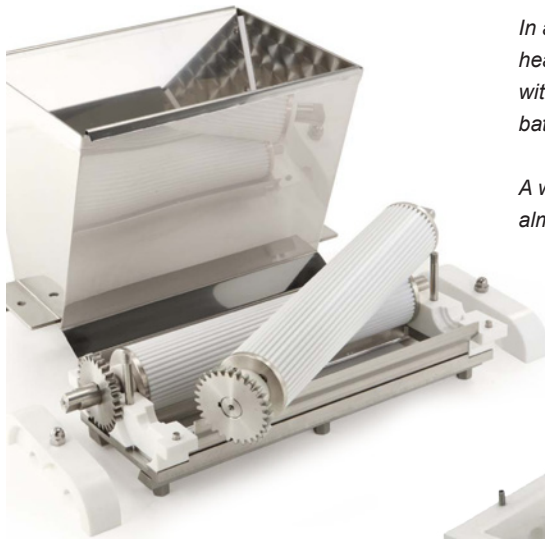

In addition to the standard hard dough dosing head, (left), the **SUPREMA** can also be equipped with an optional pump head for soft doughs and batters, (below).

A wide array of nozzles and moulds allows for an almost unlimited range of shapes and sizes.

