



“Superior Commitment to Excellence”



Magna Industries

1825 Swarthmore Avenue, Lakewood, NJ 08701

Toll Free 1.800.510.9856 Office 732.905.0957 Fax 732.367.2989

www.magnaindustries.com sales@magnaindustries.com

INDEX



OVEN RACKS

PG

Bakers Aid Style - Standard & Nesting Racks	
Bottom Locator - Aluminum & Stainless Steel - Single & Double - End & Side Load.....	38
Pin Guide - Aluminum & Stainless Steel - Single & Double - End & Side Load.....	38
Top Lift - Aluminum & Stainless Steel - Single & Double - End & Side Load.....	38
Baxter, Style - Standard & Nesting Racks (Will fit all manufacturers that use Baxter style lift)	
Model - Aluminum & Stainless Steel - Single - End & Side Load.....	30
Model - Aluminum & Stainless Steel - Single & Double - End & Side Load.....	30
Dahlen/Gemini Style - Standard & Nesting Racks	
Model 1000 - Aluminum & Stainless - Single - End Load - 65"H.....	31
Model 2000 - Aluminum & Stainless - Single - End & Side Load - 74"H.....	31
Model 4000 - Aluminum & Stainless - Double - Side Load - 74"H.....	31
Model 9100-02 - Roller Coupler - Aluminum & Stainless - Single - End Load - 72"H.....	32
Model 9040-42 - Roller Coupler - Aluminum & Stainless - Steel Double - Side Load - 72"H.....	32
Model 9100-02 - Channel Coupler - Aluminum & Stainless - Single - End Load - 69.8"H.....	33
Model 9040-42 - Channel Coupler - Aluminum & Stainless Steel - Double - Side Load - 69.8"H.....	33
Model 9060-62 - No Coupler - Aluminum & Stainless Steel - Double - Side Load - 70.94"H.....	34
Empire Style - Standard & Nesting Racks.....	40
Lucks Style - Standard & Nesting Racks	
Model R10 & R20 - Aluminum & Stainless Steel - Single & Double - End & Side Load.....	34
Miwe Style - Standard & Nesting Racks	
Bottom Locator - Aluminum & Stainless Steel - Single & Double - End & Side Load.....	39
Top Lift - Aluminum & Stainless Steel - Single & Double - End & Side Load.....	30
Oven Rack Coupler Information.....	40
Revent & Hobart Style - Standard & Nesting Racks	
"A" Style Coupler - Aluminum & Stainless Steel - Single Double - End & Side Load.....	35
"B" Style Coupler - Aluminum & Stainless Steel - Single Double - End & Side Load.....	36
"C" Style Coupler - Aluminum & Stainless Steel - Single Double - End & Side Load.....	37
"D" Style Coupler - Aluminum & Stainless Steel - Single Double - End & Side Load.....	38

PAN RACKS/CARTS

Bun Pan Racks	
Heavy Duty - Aluminum & Stainless Steel - End Load.....	1
Heavy Duty - Aluminum & Stainless Steel - Side Load.....	2
Standard Duty - Aluminum & Stainless Steel - End Load.....	3
Standard Duty - Aluminum & Stainless Steel - Side Load.....	4
Super Heavy Duty - Aluminum - End & Side Load.....	9
Industrial - Magnum Series - Aluminum & Stainless Steel - Single or Double.....	10
Cabinets/Enclosed Racks.....	17
Can Storage Racks.....	20
Channel Frame Racks.....	11
Channel Slide Racks.....	12
Cooling Racks.....	14
Display Racks with Slanted Shelves.....	15
DOLLIES & TRUCKS.....	22
DONUT RACKS/ACCESSORIES.....	11
DUNNAGE RACKS	
Mobile Dunnage Racks.....	23
Stationary Dunnage Racks.....	23
HALF SIZE / UNDER COUNTER RACKS.....	14
KNOCK DOWN RACKS.....	5
LUG CARTS.....	18
MIXER BOWL STANDS & LIFT.....	25
MOBILE RACKS/WORK-TOP.....	13
MERCHANDIZING RACKS.....	15
NESTING RACKS.....	6-8
PAN WASHER RACKS.....	21
PIZZA PAN RACKS.....	20
PLATTER CARTS.....	19
POLY BOX RACKS.....	19
PROOFING BOARD STORAGE TRUCKS.....	22
ROTISSERIE CHICKEN SPIT RACKS.....	20
SHEET PAN TRUCKS & DOLLIES.....	22
TRANSPORTATION RACKS.....	13
TRAY DRYING RACKS.....	21
U-BOAT CARTS.....	24
UNIVERSAL RACKS.....	18
VERTICAL TRAY STORAGE RACKS.....	16
UTILITY - MATERIAL HANDLING CARTS.....	24
WIRE SLIDE RACKS.....	12
WIRE "TREE" RACKS.....	21

Index



The photos are from actual production pieces and represent typical configurations. Actual final product may differ from photos shown. The specifications may change without prior notice.

INDEX



PANS/TRAYS	PG
ANGEL FOOD CAKE PANS.....	52
BAGUETTE PANS.....	49
BREAD PANS.....	46
BUN PANS.....	48
BUNDT CAKE PANS.....	52
CAKE PANS.....	53
CRIMPED BREAD PANS.....	48
DISPLAY PANS.....	55
HAM BURGER BUN PANS.....	48
HEARTH BREAD PANS.....	47
HOT DOG BUN PANS.....	48
MECATHERM STYLE TRAYS.....	50
MUFFIN PANS.....	51
MUFFIN TOP PANS.....	48
PERFORATED SCREENS, COOKIE SHEETS.....	56
PLASTIC PLATTERS & TRAYS.....	26
PULLMAN PANS AND COVERS.....	47
SHEET PAN EXTENDERS & CAKE RINGS.....	54
SHEET PANS.....	55
SPECIALTY MUFFIN PANS.....	52
SPRINGFORM CAKE PANS.....	54
SUB-SANDWICH ROLL PANS.....	48
TRAYS & PLATTERS.....	26
RACK OPTIONS & UPGRADES.....	44
REPLACEMENT CASTERS & WHEELS.....	45
BAKING ACCESSORIES	
BAKERS ACCESSORIES.....	42
BAGEL MAKER ACCESSORIES.....	43
BULK MOVERS.....	26
CASTERS & WHEELS.....	45
INGREDIENT BINS.....	41
INGREDIENT HANDLING EQUIPMENT.....	41
LUGS POLYETHYLENE.....	18,42
RACK COVERS.....	42
RETARDING BOXES.....	26
TABLES & SHELVES	
ALUMINUM WALL SHELVES.....	29
BOAT RACKS.....	29
CANTILEVER SHELVING.....	Call
EQUIPMENT STANDS.....	28
WORK TABLES & BENCHES.....	27
CUSTOM AND SPECIAL ORDERS.....	59,60
HOW TO ORDER.....	61
ORDER FORM.....	67
RELEASE COATING INFORMATION.....	58
PRODUCT MAINTENANCE	
SAFETY & MAINTENANCE INFORMATION.....	57
LUBRICATION.....	57
CLEANING.....	57
INDEX BY ITEM NUMBER.....	62-66
TERMS & CONDITIONS OF SALE.....	68
WARRANTY.....	61

The use of any trademarks or trade names within this document is solely intended to provide assistance or information for people who use these products. Lynndale Stainless disclaims any proprietary intent in trademarks or names other than their own.

The photos are from actual production pieces and represent typical configurations. Actual final product may differ from photos shown. The specifications may change without prior notice.



BUN PAN HEAVY DUTY END LOAD RACKS

Bun Pan Heavy Duty Racks



Plate Casters - End Load Overall Dimensions: 65"H x 20.5"W x 26"D

Aluminum	Stainless Steel	Spacing/ Capacity
Item#	Item#	
#2026-P	#6060-P	2" / 27 Pans
#2027-P	#6059-P	3" / 18 Pans
#2028-P	#6058-P	4" / 14 Pans
#2029-P	#6057-P	5" / 11 Pans
#2030-P	#6056-P	6" / 09 Pans

Plate Casters - End Load Overall Dimensions: 70"H x 20.5"W x 26"D

Aluminum	Stainless Steel	Spacing/ Capacity
Item#	Item#	
#4205-P	#6065-P	2" / 30 Pans
#4612-P	#6064-P	3" / 20 Pans
#4615-P	#6063-P	4" / 15 Pans
#4619-P	#6062-P	5" / 12 Pans
#4623-P	#6061-P	6" / 10 Pans

Stem Casters - End Load Overall Dimensions: 65"H x 20.5"W x 26"D

Aluminum	Stainless Steel	Spacing/ Capacity
Item#	Item#	
#1813-P	#6045-P	2" / 27 Pans
#1277-P	#6044-P	3" / 18 Pans
#1814-P	#6043-P	4" / 14 Pans
#1815-P	#6042-P	5" / 11 Pans
#1816-P	#6041-P	6" / 09 Pans

Stem Casters - End Load Overall Dimensions: 70"H x 20.5"W x 26"D

Aluminum	Stainless Steel	Spacing/ Capacity
Item#	Item#	
#4000-P	#6050-P	2" / 30 Pans
#4610-P	#6049-P	3" / 20 Pans
#4613-P	#6048-P	4" / 15 Pans
#4617-P	#6047-P	5" / 12 Pans
#4621-P	#6046-P	6" / 10 Pans

SPECIFICATIONS:

- Heavy duty tubular construction, all heli-arc welded.
- Welded angle pan slides.
- Will accommodate 18"x13" trays, 18"x26" trays and 17"x25" fryer screens.
- Two 18"x13" pans per shelf on end end loading rack only.
- Rolls easily on 4" or 5" casters.
- Shipped set up, ready for use.
- Call factory for quotes on your custom needs.

*Additional Options: See Page 44 & 45



ITEM #4619-P
ITEM #6062-P

Option:

Center flat bar and tubular brace above the base design.
To order: Remove (-P) from the end of the Item Number.

Caster Upgrade Options:

Add (-HGF) suffix to Item number for 5" Plate Caster
Add (-HJM) suffix to Item number for 5" Stem Caster



ITEM #1266 (4")
ITEM #2208 (5")



ITEM #9021 (4")
ITEM #9021-5 (5")

Replacement Plate Casters (Set of 4):

Item #1266 Plate Caster 4" wheel

Item #2208 Plate Caster 5" wheel

Replacement Stem Casters (Set of 4):

Item #9021 Stem Caster 4" wheel

Item #9021-5 Stem Caster 5" wheel

*Additional Options: See Pg. 44 & 45



The photos are from actual production pieces and represent typical configurations. Actual final product may differ from photos shown. The specifications may change without prior notice.

BUN PAN HEAVY DUTY SIDE LOAD RACKS

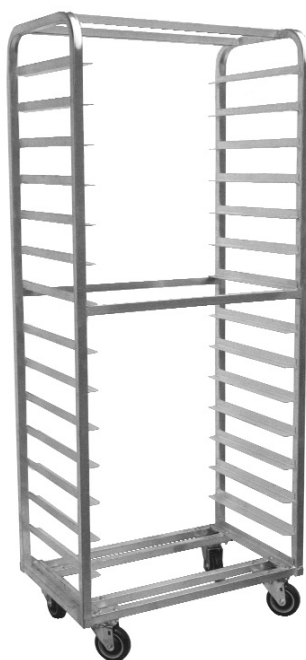
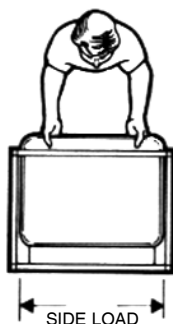

ITEM# 4616-P
ITEM# 7324-P

Plate Casters - Side Load Overall Dimensions: 65"H x 28.5"W x 18"D

Aluminum	Stainless Steel	Spacing/ Capacity
Item#	Item#	
#2031-P	#7327-P	2" / 27 Pans
#2032-P	#7328-P	3" / 18 Pans
#2033-P	#7329-P	4" / 14 Pans
#2034-P	#7330-P	5" / 11 Pans
#2035-P	#7331-P	6" / 09 Pans

Plate Casters - Side Load Overall Dimensions: 70"H x 28.5"W x 18"D

Aluminum	Stainless Steel	Spacing/ Capacity
Item#	Item#	
#4609-P	#7322-P	2" / 30 Pans
#4611-P	#7323-P	3" / 20 Pans
#4616-P	#7324-P	4" / 15 Pans
#4620-P	#7325-P	5" / 12 Pans
#4624-P	#7326-P	6" / 10 Pans

Stem Casters - Side Load Overall Dimensions: 65"H x 28.5"W x 18"D

Aluminum	Stainless Steel	Spacing/ Capacity
Item#	Item#	
#1817-P	#7332-P	2" / 27 Pans
#1818-P	#7333-P	3" / 18 Pans
#1819-P	#7334-P	4" / 14 Pans
#1820-P	#7335-P	5" / 11 Pans
#1821-P	#7336-P	6" / 09 Pans

Stem Casters - Side Load Overall Dimensions: 70"H x 28.5"W x 18"D

Aluminum	Stainless Steel	Spacing/ Capacity
Item#	Item#	
#4570-P	#7337-P	2" / 30 Pans
#4158-P	#7338-P	3" / 20 Pans
#4614-P	#7339-P	4" / 15 Pans
#4618-P	#7340-P	5" / 12 Pans
#4622-P	#7341-P	6" / 10 Pans

Option:

Center flat bar and tubular brace above the base design.
To order: Remove (-P) from the end of the Item Number.

Caster Upgrade Options:

Add (-HGF) suffix to Item number for 5" Plate Caster
Add (-HJM) suffix to Item number for 5" Stem Caster



ITEM #1266 (4")
ITEM #2208 (5")



ITEM #9021 (4")
ITEM #9021-5 (5")

Replacement Plate Casters (Set of 4):

Item #1266 Plate Caster 4" wheel

Item #2208 Plate Caster 5" wheel

Replacement Stem Casters (Set of 4):

Item #9021 Stem Caster 4" wheel

Item #9021-5 Stem Caster 5" wheel

*Additional Options: See Pg. 44 & 45

SPECIFICATIONS:

- Heavy duty tubular construction, all heli-arc welded.
- Welded angle pan slides.
- Will accommodate 18"x26" trays and 17"x25" fryer screens.
- Rolls easily on 4" or 5" casters.
- Shipped set up, ready for use.
- Call factory for quotes on your custom needs.

*Additional Options: See Pg. 44 & 45

Bun Pan Heavy Duty Racks



The photos are from actual production pieces and represent typical configurations. Actual final product may differ from photos shown. The specifications may change without prior notice.

BUN PAN STANDARD DUTY END LOAD RACKS

Bun Pan Standard Duty Racks



Plate Casters - End Load Overall Dimensions: 65"H x 20.5"W x 26"D

Aluminum	Stainless Steel	Spacing/ Capacity
Item#	Item#	
#2026E	#6060E	2" / 27 Pans
#2027E	#6059E	3" / 18 Pans
#2028E	#6058E	4" / 14 Pans
#2029E	#6057E	5" / 11 Pans
#2030E	#6056E	6" / 09 Pans

Plate Casters - End Load Overall Dimensions: 70"H x 20.5"W x 26"D

Aluminum	Stainless Steel	Spacing/ Capacity
Item#	Item#	
#4205E	#6065E	2" / 30 Pans
#4612E	#6064E	3" / 20 Pans
#4615E	#6063E	4" / 15 Pans
#4619E	#6062E	5" / 12 Pans
#4623E	#6061E	6" / 10 Pans

Stem Casters - End Load Overall Dimensions: 65"H x 20.5"W x 26"D

Aluminum	Stainless Steel	Spacing/ Capacity
Item#	Item#	
#1813E	#6045E	2" / 27 Pans
#1277E	#6044E	3" / 18 Pans
#1814E	#6043E	4" / 14 Pans
#1815E	#6042E	5" / 11 Pans
#1816E	#6041E	6" / 09 Pans

Stem Casters - End Load Overall Dimensions: 70"H x 20.5"W x 26"D

Aluminum	Stainless Steel	Spacing/ Capacity
Item#	Item#	
#4000E	#6050E	2" / 30 Pans
#4610E	#6049E	3" / 20 Pans
#4613E	#6048E	4" / 15 Pans
#4617E	#6047E	5" / 12 Pans
#4621E	#6046E	6" / 10 Pans

SPECIFICATIONS:

- Standard duty tubular construction, all heli-arc welded.
- Welded angle pan slides.
- Will accommodate 18"x13" trays, 18"x26" trays and 17"x25" fryer screens.
- Two 18"x13" pans per shelf on end loading rack only.
- Rolls easily on 4" or 5" casters.
- Shipped set up, ready for use.
- Call factory for quotes on your custom needs.



ITEM #4619E
ITEM #6062E



END LOAD

Caster Upgrade Options:

Add (-HGF) suffix to Item number for 5" Plate Caster
Add (-HJM) suffix to Item number for 5" Stem Caster



ITEM #1266 (4")
ITEM #2208 (5")



ITEM #9021 (4")
ITEM #9021-5 (5")

Replacement Plate Casters (Set of 4):

Item #1266 Plate Caster 4" wheel
Item #2208 Plate Caster 5" wheel

Replacement Stem Casters (Set of 4):

Item #9021 Stem Caster 4" wheel
Item #9021-5 Stem Caster 5" wheel

*Additional Options: See Pg. 44 & 45



The photos are from actual production pieces and represent typical configurations. Actual final product may differ from photos shown. The specifications may change without prior notice.

BUN PAN STANDARD DUTY SIDE LOAD RACKS



Plate Casters - Side Load Overall Dimensions: 65"H x 28.5"W x 18"D

Aluminum	Stainless Steel	Spacing/ Capacity
Item#	Item#	
#2031E	#7327E	2" / 27 Pans
#2032E	#7328E	3" / 18 Pans
#2033E	#7329E	4" / 14 Pans
#2034E	#7330E	5" / 11 Pans
#2035E	#7331E	6" / 09 Pans

Plate Casters - Side Load Overall Dimensions: 70"H x 28.5"W x 18"D

Aluminum	Stainless Steel	Spacing/ Capacity
Item#	Item#	
#4609E	#7322E	2" / 30 Pans
#4611E	#7323E	3" / 20 Pans
#4616E	#7324E	4" / 15 Pans
#4620E	#7325E	5" / 12 Pans
#4624E	#7326E	6" / 10 Pans

Stem Casters - Side Load Overall Dimensions: 65"H x 28.5"W x 18"D

Aluminum	Stainless Steel	Spacing/ Capacity
Item#	Item#	
#1817E	#7332E	2" / 27 Pans
#1818E	#7333E	3" / 18 Pans
#1819E	#7334E	4" / 14 Pans
#1820E	#7335E	5" / 11 Pans
#1821E	#7336E	6" / 09 Pans

Stem Casters - Side Load Overall Dimensions: 70"H x 28.5"W x 18"D

Aluminum	Stainless Steel	Spacing/ Capacity
Item#	Item#	
#4570E	#7337E	2" / 30 Pans
#4158E	#7338E	3" / 20 Pans
#4614E	#7339E	4" / 15 Pans
#4618E	#7340E	5" / 12 Pans
#4622E	#7341E	6" / 10 Pans

Caster Upgrade Options:

Add (-HGF) suffix to Item number for 5" Plate Caster
Add (-HJM) suffix to Item number for 5" Stem Caster



ITEM #1266 (4")
ITEM #2208 (5")



ITEM #9021 (4")
ITEM #9021-5 (5")

Replacement Plate Casters (Set of 4):

Item #1266 Plate Caster 4" wheel
Item #2208 Plate Caster 5" wheel

Replacement Stem Casters (Set of 4):

Item #9021 Stem Caster 4" wheel
Item #9021-5 Stem Caster 5" wheel

SPECIFICATIONS:

- Standard duty tubular construction, all heli-arc welded.
- Welded angle pan slides.
- Will accommodate 18"x26" trays and 17"x25" fryer screens.
- Rolls easily on 4" or 5" casters.
- Shipped set up, ready for use.
- Call factory for quotes on your custom needs.

*Additional Options: See Pg. 44 & 45

Bun Pan Standard Duty Racks



The photos are from actual production pieces and represent typical configurations. Actual final product may differ from photos shown. The specifications may change without prior notice.

BUN PAN KNOCK DOWN STANDARD DUTY RACKS END LOAD & SIDE LOAD



Unique Patented Clamping Brackets Prevent Wobbling

Stem Casters - End Load

Overall Dimensions: 65"H x 20.875"W x 26.375"D

Aluminum	Stainless Steel	Spacing/ Capacity
Item#	Item#	
#1813KD	#6045KD	2" / 27 Pans
#1277KD	#6044KD	3" / 18 Pans
#1814KD	#6043KD	4" / 14 Pans
#1815KD	#6042KD	5" / 11 Pans
#1816KD	#6041KD	6" / 09 Pans

Stem Casters - End Load

Overall Dimensions: 70"H x 20.875"W x 26.375"D

Aluminum	Stainless Steel	Spacing/ Capacity
Item#	Item#	
#4000KD	#6050KD	2" / 30 Pans
#4610KD	#6049KD	3" / 20 Pans
#4613KD	#6048KD	4" / 15 Pans
#4617KD	#6047KD	5" / 12 Pans
#4621KD	#6046KD	6" / 10 Pans

Stem Casters - Side Load

Overall Dimensions: 65"H x 28.875"W x 18.375"D

Aluminum	Stainless Steel	Spacing/ Capacity
Item#	Item#	
#1817KD	#7332KD	2" / 27 Pans
#1818KD	#7333KD	3" / 18 Pans
#1819KD	#7334KD	4" / 14 Pans
#1820KD	#7335KD	5" / 11 Pans
#1821KD	#7336KD	6" / 09 Pans

Stem Casters - Side Load

Overall Dimensions: 70"H x 28.875"W x 18.375"D

Aluminum	Stainless Steel	Spacing/ Capacity
Item#	Item#	
#4570KD	#7337KD	2" / 30 Pans
#4158KD	#7338KD	3" / 20 Pans
#4614KD	#7339KD	4" / 15 Pans
#4618KD	#7340KD	5" / 12 Pans
#4622KD	#7341KD	6" / 10 Pans



ITEM #4610KD
ITEM #6049KD

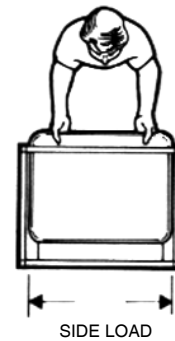

ITEM #9433



ITEM #9434

SPECIFICATIONS:

- Standard duty tubular frame, heli-arc welded.
- Welded angle pan slides.
- Will accommodate 18"x13" trays and 18"x26" trays.
- Two 18"x13" pans per shelf on end loading rack only.
- Rolls easily on 4" casters.
- Shipped knock down, requires assembly.
- Call factory for quotes on your custom needs.

Replacement Stem Casters (Set of 4):

Item #39508 Stem Caster 4" wheel

Replacement Socket for Stem Caster (Set of 4):

Item #39509 Stem Caster 4" wheel

*Additional Options: See Pg. 44 & 45

The photos are from actual production pieces and represent typical configurations. Actual final product may differ from photos shown. The specifications may change without prior notice.

Bun Pan Knock Down Racks



BUN PAN NESTING HEAVY DUTY END LOAD RACKS



Unique Nesting Design Saves Up To 60% Floor Space (Z)

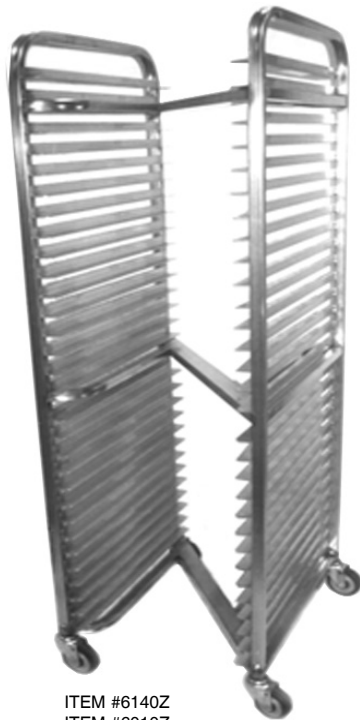

ITEM #6140Z
ITEM #6010Z

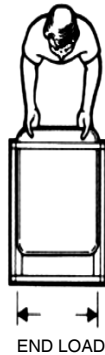

Plate Casters - End Load

Overall Dimensions: 65"H x 20.5"W x 26"D

Aluminum	Stainless Steel	Spacing/ Capacity
Item#	Item#	
#6125Z	#6025Z	2" / 27 Pans
#6124Z	#6024Z	3" / 18 Pans
#6123Z	#6023Z	4" / 14 Pans
#6122Z	#6022Z	5" / 11 Pans
#6121Z	#6021Z	6" / 09 Pans

Plate Casters - End Load

Overall Dimensions: 70"H x 20.5"W x 26"D

Aluminum	Stainless Steel	Spacing/ Capacity
Item#	Item#	
#6130Z	#6030Z	2" / 30 Pans
#6129Z	#6029Z	3" / 20 Pans
#6128Z	#6028Z	4" / 15 Pans
#6127Z	#6027Z	5" / 12 Pans
#6126Z	#6026Z	6" / 10 Pans

Stem Casters - End Load

Overall Dimensions: 65"H x 20.5"W x 26"D

Aluminum	Stainless Steel	Spacing/ Capacity
Item#	Item#	
#6135Z	#6005Z	2" / 27 Pans
#6134Z	#6004Z	3" / 18 Pans
#6133Z	#6003Z	4" / 14 Pans
#6132Z	#6002Z	5" / 11 Pans
#6131Z	#6001Z	6" / 09 Pans

Stem Casters - End Load

Overall Dimensions: 70"H x 20.5"W x 26"D

Aluminum	Stainless Steel	Spacing/ Capacity
Item#	Item#	
#6140Z	#6010Z	2" / 30 Pans
#6139Z	#6009Z	3" / 20 Pans
#6138Z	#6008Z	4" / 15 Pans
#6137Z	#6007Z	5" / 12 Pans
#6136Z	#6006Z	6" / 10 Pans

Caster Upgrade Options:

Add (-HGF) suffix to Item number for 5" Plate Caster
Add (-HJM) suffix to Item number for 5" Stem Caster



ITEM #1266 (4")
ITEM #2208 (5")



ITEM #9021 (4")
ITEM #9021-5 (5")

Replacement Plate Casters (Set of 4):

Item #1266 Plate Caster 4" wheel

Item #2208 Plate Caster 5" wheel

Replacement Stem Casters (Set of 4):

Item #9021 Stem Caster 4" wheel

Item #9021-5 Stem Caster 5" wheel

*Additional Options: See Pg. 44 & 45

SPECIFICATIONS:

- Heavy duty tubular construction, all heli-arc welded.
- Welded angle pan slides.
- Will accommodate 18"x13" trays, 18"x26" trays and 17"x25" fryer screens.
- Two 18"x13" pans per shelf on end loading rack only.
- Rolls easily on 4" or 5" casters.
- Shipped set up, ready for use.
- Call factory for quotes on your custom needs.

Bun Pan Nesting Heavy Duty Racks



The photos are from actual production pieces and represent typical configurations. Actual final product may differ from photos shown. The specifications may change without prior notice.

BUN PAN NESTING HEAVY DUTY SIDE LOAD RACKS

Bun Pan Nesting Heavy Duty Racks



Unique Nesting Design Saves Up To 60% Floor Space (Z)

Plate Casters - Side Load

Overall Dimensions: 65"H x 28.5"W x 18"D

Aluminum Item#	Stainless Steel Item#	Spacing/ Capacity
#7535Z	#8266Z	2" / 27 Pans
#7534Z	#8267Z	3" / 18 Pans
#7533Z	#8268Z	4" / 14 Pans
#7532Z	#8269Z	5" / 11 Pans
#7531Z	#8270Z	6" / 09 Pans

Plate Casters - Side Load

Overall Dimensions: 70"H x 28.5"W x 18"D

Aluminum Item#	Stainless Steel Item#	Spacing/ Capacity
#7525Z	#8271Z	2" / 30 Pans
#6343Z	#8272Z	3" / 20 Pans
#7524Z	#8273Z	4" / 15 Pans
#7523Z	#8274Z	5" / 12 Pans
#7522Z	#8275Z	6" / 10 Pans

Stem Casters - Side Load

Overall Dimensions: 65"H x 28.5"W x 18"D

Aluminum Item#	Stainless Steel Item#	Spacing/ Capacity
#7530Z	#8276Z	2" / 27 Pans
#7529Z	#8277Z	3" / 18 Pans
#7528Z	#8278Z	4" / 14 Pans
#7527Z	#8279Z	5" / 11 Pans
#7526Z	#8280Z	6" / 09 Pans

Stem Casters - Side Load

Overall Dimensions: 70"H x 28.5"W x 18"D

Aluminum Item#	Stainless Steel Item#	Spacing/ Capacity
#7521Z	#8281Z	2" / 30 Pans
#7520Z	#8282Z	3" / 20 Pans
#7519Z	#8283Z	4" / 15 Pans
#7518Z	#8284Z	5" / 12 Pans
#7517Z	#8285Z	6" / 10 Pans

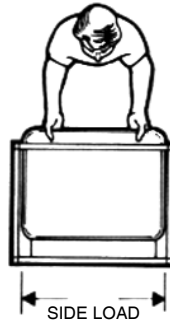

ITEM #7521Z
ITEM #8281Z

Caster Upgrade Options:

Add (-HGF) suffix to Item number for 5" Plate Caster
Add (-HJM) suffix to Item number for 5" Stem Caster



ITEM #1266 (4")
ITEM #2208 (5")



ITEM #9021 (4")
ITEM #9021-5 (5")

SPECIFICATIONS:

- Heavy duty tubular construction, all heli-arc welded.
- Welded angle pan slides.
- Will accommodate 18"x26" trays and 17"x25" fryer screens.
- Rolls easily on 4" or 5" casters.
- Shipped set up, ready for use.
- Call factory for quotes on your custom needs.

Replacement Plate Casters (Set of 4):

Item #1266 Plate Caster 4" wheel
Item #2208 Plate Caster 5" wheel

Replacement Stem Casters (Set of 4):

Item #9021 Stem Caster 4" wheel
Item #9021-5 Stem Caster 5" wheel

*Additional Options: See Pg. 44 & 45



The photos are from actual production pieces and represent typical configurations. Actual final product may differ from photos shown. The specifications may change without prior notice.

BUN PAN EASY NEST SUPER HEAVY DUTY RACKS END LOAD & SIDE LOAD



Unique Nesting Design Saves Up To 60% Floor Space (U)



ITEM #6149



ITEM #7502

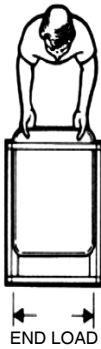

END LOAD

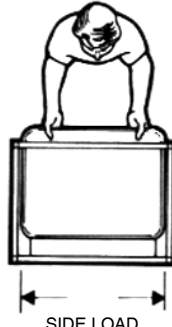

SIDE LOAD

Caster Upgrade Options:

Add (-HGF) suffix to Item number for 5" Plate Caster
Add (-HJK) suffix to Item number for 5" Stem Caster



ITEM #1266 (4")
ITEM #2208 (5")



ITEM #9021-1063 (4")
ITEM #9021-1063-5 (5")

Replacement Plate Casters (Set of 4):

Item #1266 Plate Caster 4" wheel

Item #2208 Plate Caster 5" wheel

Replacement Stem Casters (Set of 4):

Item #9021-1063 Stem Caster 4" wheel

Item #9021-1063-5 Stem Caster 5" wheel

*Additional Options: See Pg. 44 & 45

End Load - Aluminum

Overall Dimensions: 65"H x 21"W x 26"D

Plate Casters Item#	Stem Casters Item#	Spacing / Capacity
#6145	#6155	2" / 27 Pans
#6144	#6154	3" / 18 Pans
#6143	#6153	4" / 14 Pans
#6142	#6152	5" / 11 Pans
#6141	#6151	6" / 09 Pans

End Load - Aluminum

Overall Dimensions: 70"H x 21"W x 26"D

Plate Casters Item#	Stem Casters Item#	Spacing / Capacity
#6150	#6160	2" / 30 Pans
#6149	#6159	3" / 20 Pans
#6148	#6158	4" / 15 Pans
#6147	#6157	5" / 12 Pans
#6146	#6156	6" / 10 Pans

Side Load - Aluminum

Overall Dimensions: 65"H x 29"W x 18"D

Plate Casters Item#	Stem Casters Item#	Spacing / Capacity
#7516	#7511	2" / 27 Pans
#7515	#7510	3" / 18 Pans
#7514	#7509	4" / 14 Pans
#7513	#7508	5" / 11 Pans
#7512	#7507	6" / 09 Pans

Side Load - Aluminum

Overall Dimensions: 70"H x 29"W x 18"D

Plate Casters Item#	Stem Casters Item#	Spacing / Capacity
#7506	#7503	2" / 30 Pans
#3735	#7502	3" / 20 Pans
#3736	#7501	4" / 15 Pans
#7505	#7500	5" / 12 Pans
#7504	#7499	6" / 10 Pans

SPECIFICATIONS:

- Super heavy duty tubular construction, all heli-arc welded.
- Welded angle pan slides.
- Will accommodate 18"x13" trays, 18"x26" trays and 17"x25" fryer screens.
- Two 18"x13" pans per shelf on end loading rack only.
- Rolls easily on 4" or 5" casters.
- Shipped set up, ready for use.
- Call factory for quotes on your custom needs.

Bun Pan Easy Nest Super Heavy Duty Racks



The photos are from actual production pieces and represent typical configurations. Actual final product may differ from photos shown. The specifications may change without prior notice.

BUN PAN SUPER HEAVY DUTY RACKS

END LOAD & SIDE LOAD

Bun Pan Super Heavy Duty Racks



End Load - Aluminum

Overall Dimensions: 65"H x 21"W x 26"D

Plate Casters Item#	Stem Casters Item#	Spacing / Capacity
#6100	#6080	2" / 27 Pans
#6099	#6079	3" / 18 Pans
#6098	#6078	4" / 14 Pans
#6097	#6077	5" / 11 Pans
#6096	#6076	6" / 09 Pans

End Load - Aluminum

Overall Dimensions: 70"H x 21"W x 26"D

Plate Casters Item#	Stem Casters Item#	Spacing / Capacity
#2492	#6085	2" / 30 Pans
#2234	#6084	3" / 20 Pans
#6103	#6083	4" / 15 Pans
#6102	#6082	5" / 12 Pans
#6101	#6081	6" / 10 Pans

Side Load - Aluminum

Overall Dimensions: 65"H x 29"W x 18"D

Plate Casters Item#	Stem Casters Item#	Spacing / Capacity
#7493	#7498	2" / 27 Pans
#7492	#7497	3" / 18 Pans
#7491	#7496	4" / 14 Pans
#7490	#7495	5" / 11 Pans
#7489	#7494	6" / 09 Pans

Side Load - Aluminum

Overall Dimensions: 70"H x 29"W x 18"D

Plate Casters Item#	Stem Casters Item#	Spacing / Capacity
#6791	#7488	2" / 30 Pans
#4131	#7487	3" / 20 Pans
#4127	#7486	4" / 15 Pans
#6454	#7485	5" / 12 Pans
#6950	#7484	6" / 10 Pans



ITEM #2234



ITEM #7487



END LOAD

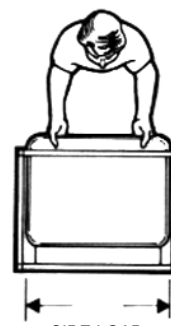

SIDE LOAD

Caster Upgrade Options:

Add (-HGF) suffix to Item number for 5" Plate Caster
Add (-HJK) suffix to Item number for 5" Stem Caster



ITEM #1266 (4")
ITEM #2208 (5")



ITEM #9021-1063 (4")
ITEM #9021-1063-5 (5")

SPECIFICATIONS:

- Super heavy duty tubular construction, all heli-arc welded.
- Welded angle pan slides.
- Will accommodate 18"x13" trays, 18"x26" trays and 17"x25" fryer screens.
- Two 18"x13" pans per shelf on end loading rack only.
- Rolls easily on 4" or 5" casters.
- Shipped set up, ready for use.
- Call factory for quotes on your custom needs.

Replacement Plate Casters (Set of 4):

Item #1266 Plate Caster 4" wheel
Item #2208 Plate Caster 5" wheel

Replacement Stem Casters (Set of 4):

Item #9021-1063 Stem Caster 4" wheel
Item #9021-1063-5 Stem Caster 5" wheel

*Additional Options: See Pg. 44 & 45



The photos are from actual production pieces and represent typical configurations. Actual final product may differ from photos shown. The specifications may change without prior notice.

BUN PAN INDUSTRIAL MAGNUM SERIES RACKS

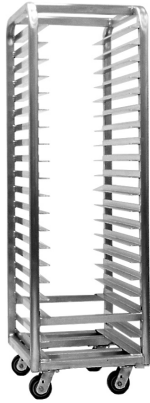

ITEM #2234-M

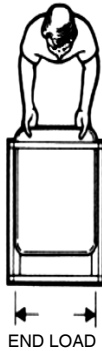

END LOAD

*Single Capacity - End Load - Plate Casters Aluminum - Dimensions: 21-3/4"W x 26"D

65"H		72"H		Spacing
End Load Item#	Capacity	End Load Item#	Capacity	
#6100-M	27 Pans	#2492-M	30Pans	2"
#6099-M	18 Pans	#2234-M	20 Pans	3"
#6098-M	14 Pans	#6103-M	15 Pans	4"
#6097-M	11 Pans	#6102-M	12 Pans	5"
#6096-M	09 Pans	#6101-M	10 Pans	6"

*Double Capacity - End Load - Plate Casters Aluminum - Dimensions: 42"W x 26"D

65"H		72"H		Spacing
End Load Item#	Capacity	End Load Item#	Capacity	
#6100D-M	54 Pans	#2492D-M	60Pans	2"
#6099D-M	36 Pans	#2234D-M	40 Pans	3"
#6098D-M	28 Pans	#6103D-M	30 Pans	4"
#6097D-M	22 Pans	#6102D-M	24 Pans	5"
#6096D-M	18 Pans	#6101D-M	20 Pans	6"

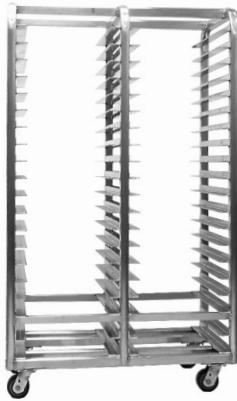

ITEM #2234D-M

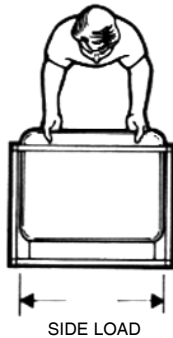

SIDE LOAD

*Single Capacity - Side Load - Plate Casters Aluminum - Dimensions: 29-3/4"W x 18"D

65"H		72"H		Spacing
Side Load Item#	Capacity	Side Load Item#	Capacity	
#7493-M	27 Pans	#6791-M	30Pans	2"
#7492-M	18 Pans	#4131-M	20 Pans	3"
#7491-M	14 Pans	#4127-M	15 Pans	4"
#7490-M	11 Pans	#6454-M	12 Pans	5"
#7489-M	09 Pans	#6950-M	10 Pans	6"

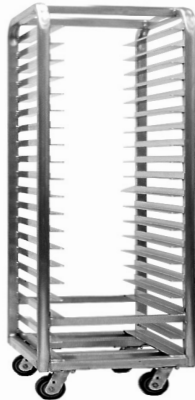

ITEM #4131-M



ITEM #6283-RB

*Double Capacity - Side Load - Plate Casters Aluminum - Dimensions: 29-3/4"W x 36"D

65"H		72"H		Spacing
Side Load Item#	Capacity	Side Load Item#	Capacity	
#7493D-M	54 Pans	#6791D-M	60Pans	2"
#7492D-M	36 Pans	#4131D-M	40 Pans	3"
#7491D-M	28 Pans	#4127D-M	30 Pans	4"
#7490D-M	22 Pans	#6454D-M	24 Pans	5"
#7489D-M	18 Pans	#6950D-M	20 Pans	6"

*For Stainless Steel Magnum Racks add suffix "-S"

Caster Upgrade Options:

- Add (-HIK) suffix to Item number for 4" Phenolic Caster
- Add (-HHG) suffix to Item number for 5" Phenolic Caster
- Add (-HEZ) suffix to Item number for 5" Donut Caster
- Add (-HEY) suffix to Item number for 6" Donut Caster

Replacement Plate Casters (Set of 4):

- Item #6283-RB Plate Caster 4" wheel
- Item #2886 Plate Caster 5" Wheel
- Item #10179-5 Plate Caster 5" Donut wheel
- Item #10179 Plate Caster 6" Donut wheel

*Additional Options: See Pg. 44 & 45

SPECIFICATIONS:

- Industrial heavy duty 1-1/2" x 1-3/4" tube
- Heli-arc welded construction.
- Will accommodate 18"x13" trays, 18"x26" trays and 17"x25" fryer screens.
- Two 18"x13" pans per shelf on end loading rack only.
- Rolls easily on 4" or 5" casters.
- Shipped set up, ready for use.
- Call factory for quotes on your custom needs.

The photos are from actual production pieces and represent typical configurations. Actual final product may differ from photos shown. The specifications may change without prior notice.



CHANNEL FRAME CONSTRUCTION RACKS



Super Heavy Duty All Welded Construction Aluminum - Plate Casters - Height: 70" End Load & Side Load - Single Capacity

End Load	Side Load	Spacing/ Capacity
23"W x 26"D	31"W x 18"D	
Item#	Item#	
#3651	#3644-30	2" / 30 Pans
#3650	#3644	3" / 20 Pans
#3649	#3641	4" / 15 Pans
#3648	#7942-12	5" / 12 Pans
#3647	#7942	6" / 10 Pans

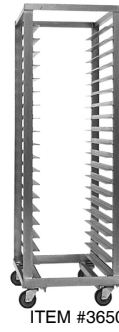

Caster Upgrade Options:

Add (-HGF) suffix to Item # for 5" Plate Caster
Add (-HEZ) suffix to Item # for 5" Donut Caster

Replacement casters (Set of 4):

Item #1266 4" wheel
Item #2208 5" wheel
Item #10179-5 5" Donut wheel
*Additional Options: See Pg. 44 & 45

Super Heavy Duty All Welded Construction Aluminum - Plate Casters - Height: 70" End Load & Side Load - Double Capacity

End Load	Side Load	Spacing/ Capacity
48"W x 26"D	31"W x 36"D	
Item#	Item#	
#22984	#22974	2" / 60 Pans
#22983	#22973	3" / 40 Pans
#22982	#22972	4" / 30 Pans
#22981	#22971	5" / 24 Pans
#22980	#22970	6" / 20 Pans

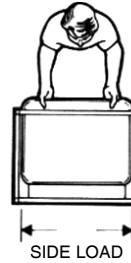
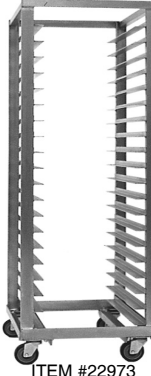

ITEM #1266 (4")
ITEM #2208 (5")

SPECIFICATIONS: Heavy duty channel frame.

- All heli-arc welded construction. Will accommodate: 18"x13" and 18"x26" trays; and 17"x25" fryer screens.
- Two 18"x13" pans per shelf on end loading rack only.
- Rolls easily on 4" or 5" casters. Shipped set up, ready for use.
- Call factory for quotes on your custom needs.

DONUT RACKS AND ACCESSORIES

End Load - Single Capacity - Aluminum

Overall Dimensions: 70"H x 25.5"W x 34"D
Sized for Donut Screen : 23" x 33"

Item#	Spacing/Capacity
#22019	3" / 20 Screens

Overall Dimensions: 70"H x 25.5"W x 24"D
Sized for Donut Screen : 23" x 23"

Item#	Spacing/Capacity
#8796	3" / 20 Screens

Overall Dimensions: 70"H x 26.5"W x 24"D
Sized for Donut Screen : 24" x 24"

Item#	Spacing/Capacity
#4215	3" / 20 Screens

Side Load - Single Capacity - Aluminum

Overall Dimensions: 70"H x 35-5/8"W x 23"D
Sized for Donut Screen : 23" x 33"

Item#	Spacing/Capacity
#6195	3" / 20 Screens

Overall Dimensions: 70"H x 36-3/8"W x 24"D
Sized for Donut Screen : 23" x 33" & 24" x 34"

Item#	Spacing/Capacity
#6195-UNI	3" / 20 Screens

SPECIFICATIONS:

- Heavy duty tubular construction, all heli-arc welded.
- Welded angle pan slides.
- Rolls easily on 4" or 5" casters.
- Shipped set up, ready for use.
- Call factory for quotes on your custom needs.

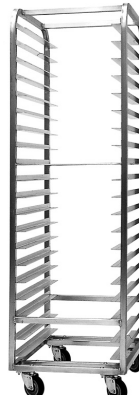

ITEM #8796



ITEM #1266 (4")

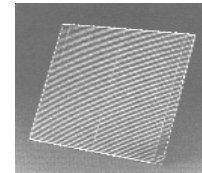

ITEM# 9508

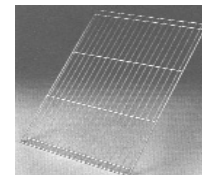

ITEM# 10584

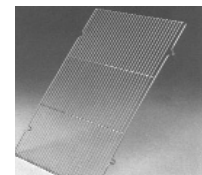

ITEM# 10585

Caster Upgrade Options:

Add (-HGF) suffix to Item # for 5" Plate Caster

Replacement casters (Set of 4):

Item #1266 4" wheel
Item #2208 5" wheel

*Additional Options: See Pg. 44 & 45

DONUT SCREENS

Item#	Description	Dimensions
#9508	Frying Screen NI	17" x 25"
#9508-1	Frying Screen NI	23" x 33"
#10584	Glazing Screen Flat	17" x 25"
#10584-1	Glazing Screen Flat	24" x 34"
#10585	Icing Screen Raised	17" x 25"
#10584-2-SS	Glazing Screen Flat SS	23" x 23"

The photos are from actual production pieces and represent typical configurations. Actual final product may differ from photos shown. The specifications may change without prior notice.



CHANNEL SLIDE END LOAD RACKS

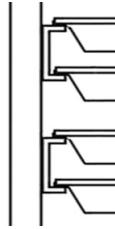
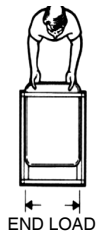

ITEM# 7127



ITEM #1266 (4")
ITEM #2208 (5")

Replacement casters (Set of 4):

Item #1266 4" wheel

Item #2208 5" wheel

*Additional Options: See Pg. 44 & 45

Heavy Duty All Welded Construction
Aluminum - Plate Casters - Height: 70"
End Load - Single Capacity
Dimensions: 20.313"W x 26"D

4" Casters	5" Casters	Spacing/ Capacity
Item# #7124-4	Item# #7124	1.5" / 40 Pans

Super Heavy Duty All Welded Construction
Aluminum - Plate Casters - Height: 70"
End Load - Single Capacity
Dimensions: 20.813"W x 26"D

4" Casters	5" Casters	Spacing/ Capacity
Item# #7127-4	Item# #7127	1.5" / 40 Pans

SPECIFICATIONS: Heavy duty tubular frame.

- All heli-arc welded construction.
- Will accommodate: 18"x13" and 18"x26" trays.
- Two 18"x13" pans per shelf on end loading rack only.
- Rolls easily on 4" or 5" casters. Shipped set up, ready for use.
- Call factory for quotes on your custom needs.

Channel & Wire Slide Racks

WIRE SLIDE RACKS



ITEM# 10487

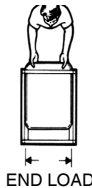

ITEM# 10525

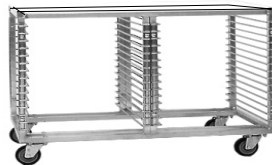

ITEM# 10526



ITEM #1266 (4")
ITEM #2208 (5")



ITEM #9021 (4")
ITEM #9021-5 (5")

Caster Upgrade Options:

Add (-HGF) suffix to Item number for 5"

Add (-HJK) suffix to Item number for 5"

Replacement casters (Set of 4):

Item #1266 4" wheel

Item #2208 5" wheel

Item #9021 4" wheel

Item #9021-5 5" wheel

*Additional Options: See Pg. 44 & 45

Heavy Duty All Welded Frame
Aluminum Frame - Nickel Plated Slides
Dimensions: 21"W x 25"D
End Load - Single Capacity

Plate Casters	Stem Casters	Height	Spacing/ Capacity
Item# #10483	Item# #10484	38"	1.5" / 18 Pans
#10485	#10486	65"	1.5" / 33 Pans
#10487	#10488	70"	1.5" / 36 Pans

Mobile Work Tables

Aluminum Frame - Nickel Plated Slides
Overall Dimensions: 21"W x 25"D x 32"H
End Load - Single Capacity

Poly-Top	AL-Top	SS-Top	Spacing/ Capacity
Item# #10525	Item# #10545	#10546	1.5" / 15 Pans

Aluminum Frame - Nickel Plated Slides
Overall Dimensions: 46"W x 25"D x 32"H
End Load - Double Capacity

Poly-Top	AL-Top	SS-Top	Spacing/ Capacity
Item# #10526	Item# #10547	#10548	1.5" / 30 Pans

SPECIFICATIONS:

- Heavy duty tubular construction, heli-arc welded.
- Nickel Plated Wire Slides.
- Will accommodate 18"x13" trays and 18"x26" trays.
- Rolls easily on 4" or 5" casters.
- Shipped set up, ready for use.
- Call factory for quotes on your stainless steel & custom needs.

The photos are from actual production pieces and represent typical configurations. Actual final product may differ from photos shown. The specifications may change without prior notice.



TRANSPORTATION RACKS



Transportation Racks & Mobile Tables

Super Heavy Duty All Welded Construction
Side Load - Aluminum - Plate Casters
Overall Dimensions: 70"H x 29"W x 18"D

4" Casters
Item# #3735-KC3
Spacing/ Capacity 3" / 20 Pans

Heavy Duty All Welded Construction
Side Load - Aluminum - Plate Casters
Overall Dimensions: 46"H x 29.5"W x 21.5"D

4" Casters
Item# #9336-46LT2
Spacing/ Capacity (*)/10 Pans

*From the top: 4 shelves - 2-5/8" spacing
5 shelves - 4-3/4" spacing
1 shelf - 2-5/8" spacing
Base Cover

SPECIFICATIONS: Heavy duty tubular frame.

- All heli-arc welded construction.
- Will accommodate: 18"x13" and 18"x26" trays.
- Two 18"x13" pans per shelf on end loading rack only.
- Rolls easily on 4" or 5" casters. Shipped set up, ready for use.
- Call factory for quotes on your custom needs.



ITEM# 3735-KC3

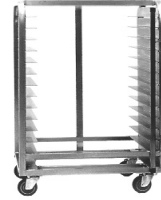

ITEM# 9336-46LT2

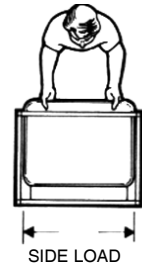

SIDE LOAD

Optional Rack Covers

Item #	Description
#9784	Cover Hercules for #9336-46LT2
#22282	Cover Hercules for #9336-70LT
#10928	Cover Hercules for #3735-KC2



ITEM #1266 (4")
ITEM #2208 (5")

Caster Upgrade Options:

Add (-HGF) suffix to Item # for 5" Plate Caster
Add (-HJM) suffix to Item # for 5" Stem Caster

Replacement casters (Set of 4):

Item #1266 4" wheel
Item #2208 5" wheel
Item #9021 4" wheel
Item #9021-5 5" wheel

*Additional Options: See Pg. 44 & 45



ITEM #9021 (4")
ITEM #9021-5 (5")

MOBILE WORK TABLES

Aluminum Frame and Angle Slides
Accommodates 18" x 26" Pan Size
End Load - Single Capacity
Overall Dimensions: 34.5"H x 20.5"W x 26"D

Poly-Top Item#	AL-Top Item#	SS-Top Item#	Spacing/ Capacity
#23810	#23820	#23830	3.5" / 7 Pans
#23811	#23821	#23831	5" / 5 Pans

Aluminum Frame and Angle Slides
Accommodates 18" x 26" Pan Size
End Load - Double Capacity
Overall Dimensions: 34.5"H x 40"W x 24"D

Poly-Top Item#	AL-Top Item#	SS-Top Item#	Spacing/ Capacity
#23812	#23822	#23832	3.5" / 14 Pans
#23813	#23823	#23833	5" / 10 Pans

Aluminum Frame and Angle Slides
Accommodates 18" x 26" Pan Size
End Load - Double Capacity
Overall Dimensions: 34.5"H x 48"W x 24"D

Poly-Top Item#	AL-Top Item#	SS-Top Item#	Spacing/ Capacity
#23814	#23824	#23834	3.5" / 7 Pans
#23815	#23825	#23835	5" / 5 Pans

SPECIFICATIONS:

- Heavy duty tubular construction, heli-arc welded.
- Welded angle pan slides.
- Rolls easily on 4" or 5" casters.
- Shipped set up, ready for use.
- Call factory for quotes on your stainless steel & custom needs.



ITEM #23810



ITEM #23812



ITEM #23814



END LOAD



ITEM #9021 (4")
ITEM #9021-5 (5")

Caster Upgrade Options:

Add (-HJM) suffix to Item # for 5" Stem Caster

Replacement casters (Set of 4):

Item #9021 4" wheel
Item #9021-5 5" wheel

*Additional Options: See Pg. 44 & 45

The photos are from actual production pieces and represent typical configurations. Actual final product may differ from photos shown. The specifications may change without prior notice.



HALF SIZE / UNDERCOUNTER RACKS

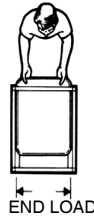

END LOAD



ITEM# 23721

End Load - Single Capacity - Stem Casters Overall Dimensions: 36"H x 20.5"W x 26"D

Aluminum Item#	Stainless Steel Item#	Spacing/ Capacity
#23721	#23731	3" / 9 Pans
#23722	#23732	4" / 7 Pans
#23723	#23733	5" / 5 Pans



ITEM #9021 (4")
ITEM #9021-5 (5")

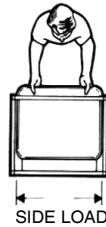

SIDE LOAD



ITEM# 23724

Side Load - Single Capacity - Stem Casters Overall Dimensions: 36"H x 28.5"W x 18"D

Aluminum Item#	Stainless Steel Item#	Spacing/ Capacity
#23724	#23734	3" / 9 Pans
#23725	#23735	4" / 7 Pans
#23725-5	#23735-5	5" / 5 Pans

Caster Upgrade Options:

Add (-HJM) suffix to Item # for 5" Stem Caster

Replacement casters (Set of 4):

Item #9021 4" wheel

Item #9021-5 5" wheel

*Additional Options: See Pg. 44 & 45

SPECIFICATIONS: Heavy duty tubular frame.

- All heli-arc welded construction.
- Will accommodate: 18"x13" and 18"x26" trays.
- Two 18"x13" pans per shelf on end loading rack only.
- Rolls easily on 4" or 5" casters. Shipped set up, ready for use.
- Call factory for quotes on your custom needs.

Under Counter Racks

End Load - Single Capacity - Stem Casters Overall Dimensions: 32"H x 20.5"W x 26"D

Aluminum Item#	Stainless Steel Item#	Spacing/ Capacity
#23726	#23736	3" / 8 Pans
#23727	#23737	4" / 6 Pans

End Load - Single Capacity - Stem Casters Overall Dimensions: 23"H x 20.5"W x 26"D

Aluminum Item#	Stainless Steel Item#	Spacing/ Capacity
#23728	#23738	3" / 5 Pans

Half Size and Cooling Racks

COOLING RACKS



ITEM# 9026

Ideal for storing, transporting and merchandising baked goods. Equipped with Stem Casters for easy rolling. Welded aluminum frame construction with bolted-on nickel plated 5/16" wire grid shelves.

Optional: Stainless steel frame with stainless steel wire grids.

Item#	Dimensions	Spacing / Capacity
#9026	68"H x 49"W x 25"D	11" / 6 Shelves
#9026-9	68"H x 49"W x 25"D	6-1/4" / 9 Shelves
#9026-1	68"H x 72"W x 25"D	11" / 6 Shelves
#9026-19	68"H x 72"W x 25"D	6-1/4" / 9 Shelves

SPECIFICATIONS: Heavy duty tubular frame.

- All heli-arc welded construction.
- *Equipped with bolted on Nickel plated wire shelves.
- Rolls easily on 4" or 5" casters. Shipped set up, ready for use.
- Call factory for quotes on stainless steel requirements.



ITEM #9021 (4")
ITEM #9021-5 (5")

Caster Upgrade Options:

Add (-HJM) suffix to Item # for 5" Stem Caster

Replacement casters (Set of 4):

Item #9021 4" wheel

Item #9021-5 5" wheel

*Additional Options: See Pg. 44 & 45

The photos are from actual production pieces and represent typical configurations. Actual final product may differ from photos shown. The specifications may change without prior notice.



MERCHANDISING RACKS



Slanted-Shelf Merchandiser Rack / Wall Shelf. Ideal to Display Bagels or Breads utilizing wire or wicker baskets.
Dimensions: 26"D x 66"H

Aluminum Item#	Stainless Steel Item#	Wide	Shelves
#19300-3-AL	#19300-3	39"	3
#19300-5-AL	#19300-5	57.5"	3
#19300-6-AL	#19300-6	72"	3

Note: Baskets are sold separately.

SPECIFICATIONS:

- Heavy duty tubular construction, all heli-arc welded.
- Convenient merchandise identification tag holders.
- Rolls easily on 4" or 5" casters.
- Shipped set up, ready for use.
- Call factory for quotes on your custom needs.

*Additional Options: See Page 44 & 45

Caster Upgrade Options:

Add (-HJM) suffix to Item # for 5" Stem Caster

Replacement casters (Set of 4):

Item #9021 4" wheel

Item #9021-5 5" wheel



ITEM #9021 (4")
ITEM #9021-5 (5")



ITEM#19300-3

ITEM# 6757 ITEM# 6758

Bagel Baskets - Chrome Plated

Item#	Description/Size
#6757	Basket 7"x20"x6"
#6755	Basket 14"x20"x6"
#6758	Basket 21"x20"x6"
#6756	Basket 18"x24"x8"
#8495	Basket Divider 6"D x 20"L

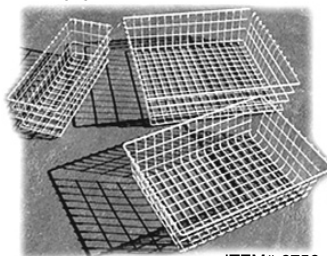

ITEM# 6756



This Rattan Wicker Basket creates an elegant and attractive back wall display. Perfect display for Baked Breads, Bagels, Pastries, and other similar items. Note: The above baskets are shown for informational purpose only and are not part of the display rack.

DISPLAY RACKS WITH SLANTED SHELVES

Perfect for Bakeries, Restaurants, Caterers, and other Food Services. Also, adds visibility and accessibility to products.

Side Load - Single Capacity - Stem Casters

Overall Dimensions: 70"H x 28"W x 22"D

Aluminum Item#	Stainless Steel Item#	Spacing/ Capacity
#23030	#23030-SS	8.75" / 7 Pans
#23031	#23031-SS	7.5" / 9 Pans

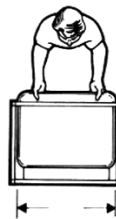

SIDE LOAD



ITEM #9021 (4")
ITEM #9021-5 (5")



ITEM# 23030

SPECIFICATIONS:

- Heavy duty tubular construction, all heli-arc welded.
- Welded angle pan slides.
- Will accommodate 18"x26" trays 17"x25" fryer screens.
- Rolls easily on 4" or 5" casters.
- Shipped set up, ready for use.
- Call factory for quotes on your custom needs.

Caster Upgrade Options:

Add (-HJM) suffix to Item # for 5" Stem Caster

Replacement casters (Set of 4):

Item #9021 4" wheel

Item #9021-5 5" wheel

*Additional Options: See Pg. 44 & 45



The photos are from actual production pieces and represent typical configurations. Actual final product may differ from photos shown. The specifications may change without prior notice.

VERTICAL TRAY STORAGE RACKS



ITEM #20790-06

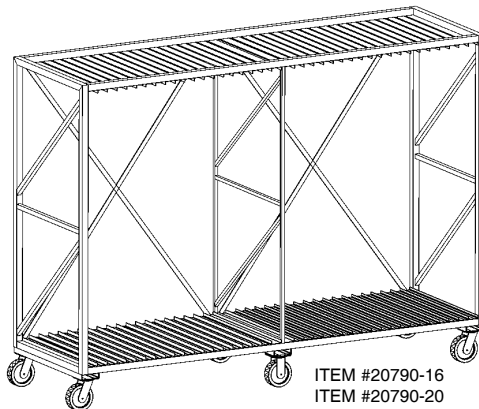

ITEM #20790-16
ITEM #20790-20



ITEM #2208 (5")



ITEM #6283-RB
ITEM #2886

Caster Upgrade Options:

Add (-HGF) suffix to Item number for 5" Polyurethane Caster
Add (-HIF) suffix to Item number for 4" Phenolic Caster
Add (-HHG) suffix to Item number for 5" Phenolic Caster

Replacement Plate Casters (Set of 4):

Item #2208 Plate Caster 5" wheel
Item #5098-5 Brake for 5" Caster #2208
Item #6283-RB Plate Caster 5" Donut wheel
Item #2886 Plate Caster 6" Donut wheel

Safely Store and Transport Trays with Full Protection to the Release Coatings Depth 31-3/4"

Aluminum	Stainless Steel	
Item#	Item#	Spacing/Capacity/
#20790-06	#20790-06-SS	2.000" / 120 Trays
Sized for tray: 600mm x 800mm		
#20790-16	#20790-16-SS	2.375" / 40 Trays
Sized for tray: 1600mm x 800mm		
#20790-20	#20790-20-SS	2.375" / 40 Trays
Sized for tray: 2000mm x 800mm		

Note: Optional heavy duty vinyl dust cover available.

Mecatherm Style Trays

Overall Dimensions: 800mm x 600mm x 40mm

Item#	Color Suffix	Configuration
#18400_TR_1xx_FT		Flat Screen
#18400_TR_2xx_xx		6 - Channels
#18400_TR_3xx_xx		7 - Channels
#18400_TR_4xx_xx		8 - Channels

Mecatherm Style Trays

Overall Dimensions: 800mm x 1600mm x 50mm

Item#	Color Suffix	Configuration
#18500_TR_1xx_FT		Flat Screen
#18500_TR_2xx_xx		16 - Channels
#18500_TR_3xx_xx		19 - Channels
#18500_TR_4xx_xx		21 - Channels

Mecatherm II Style Trays

Overall Dimensions: 800mm x 2000mm x 50mm

Item#	Color Suffix	Configuration
#18600_TR_1xx_FT		Flat Screen
#18600_TR_2xx_xx		21 - Channels
#18600_TR_3xx_xx		22 - Channels
#18600_TR_4xx_xx		23 - Channels
#18600_TR_5xx_xx		27 - Channels

BR - Brown	FB - Flat Bottom
BK - Black	RB - Round Bottom
BL - Blue	
TN - Tan	

Replacement Screens of All Sizes Available

Industrial Baguette & Flat Trays:
Ideal for Mecatherm® and other Industrial Bread Lines

SPECIFICATIONS:

- Heavy duty hell-arc welded construction.
- Will accommodate 600mm, 1600mm and 2000mm trays
- Rolls easily on 4" or 5" casters.
- Shipped set up, ready for use.
- Call factory for quotes on your custom needs.

*Additional Options: See Page 44, 45 & 50

Vertical Tray Storage Racks



The photos are from actual production pieces and represent typical configurations. Actual final product may differ from photos shown. The specifications may change without prior notice.

ENCLOSED MOBILE TRANSPORT CABINETS END LOAD ENCLOSED RACKS



Retail / Foodservice Application

Mobile Cabinets are ideal for in-store use as well as transportation. Re-inforced, non-insulated units provide long service and reduce dehydration. All Welded Aluminum Construction. 4" Casters - Dimensions: 20-7/8"W x 27-5/8"D

Item#	Height	Spc / Cap
#9380	38" - 1/2 Size	1.5" / 20 Pans
#9381	56" - 3/4 Size	1.5" / 32 Pans
#9382	70" - Full Size	1.5" / 40 Pans



ITEM# 9383

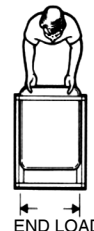

Retail / Foodservice Application

Aluminum Enclosed Mobile Cabinets 5" Casters - Dimensions: 20-7/8"W x 27-5/8"D

Item#	Height	Spc / Cap
#9388	38" - 1/2 Size	1.5" / 19 Pans
#9383	70" - Full Size	1.5" / 40 Pans



ITEM# 19187

Wholesale / Industrial Application

Heavy Duty AL Enclosed Mobile Cabinets 5" Casters - Dimensions: 20-7/8"W x 27-5/8"D

Item#	Height	Spc / Cap
#9384	70" - Full Size	1.5" / 38 Pans



ITEM# 9382



ITEM# 1541-18

ITEM# 19190

Ideal for Transporting on Trucks

Super Heavy Duty AL Enclosed Mobile Cabinets 6" Casters - Dimensions: 20-7/8"W x 27-5/8"D

Item#	Height	Spc / Cap
#9385	70" - Full Size	1.5" / 38 Pans



ITEM# 9380



ITEM #10179-5 (5")
ITEM #10179 (6")



ITEM #1266 (4")
ITEM #2208 (5")

Options:

Item#	Description
#22188	Corner Bumper (4 Pcs)
#20279-INT	Corner Bumper (4 Pcs) for Full Perimeter Setup
#22189	Full Perimeter Bumper
#20279-END	End Cap for Strip Bumper
#5098	Caster Brakes 4" (2 Pcs required per Rack)
#5098-5	Caster Brakes 5" (2 Pcs required per Rack)
#19190	Packing List Packet
#10172	Side Handles
#22191	Prison Package
#19187	Excess Moisture Removal Ventilation

SPECIFICATIONS:

- Heavy duty heli-arc welded construction.
- Will accommodate 18"x13" and 18"x26" trays
- Two 18"x13" pens per shelf on end loading racks only.
- Rolls easily on 4" or 5" casters.
- Shipped set up, ready for use.
- Call factory for quotes on your custom needs.

*Additional Options: See Page 44 & 45

Caster Upgrade Options:

Add (-HIK) suffix to Item number for 4" Phenolic Caster
Add (-HHG) suffix to Item number for 5" Phenolic Caster
Add (-HEZ) suffix to Item number for 5" Donut Caster
Add (-HEY) suffix to Item number for 6" Donut Caster

Replacement Plate Casters (Set of 4):

Item #6283-RB Plate Caster 4" wheel
Item #2886 Plate Caster 5" Wheel
Item #10179-5 Plate Caster 5" Donut wheel
Item #10179 Plate Caster 6" Donut wheel

The photos are from actual production pieces and represent typical configurations. Actual final product may differ from photos shown. The specifications may change without prior notice.



UNIVERSAL RACKS



ITEM# 38571

End Load 4" Plate Casters
All Welded Construction
Overall Dimensions: 64"H x 22"W x 26"D

Aluminum Item#	Stainless Steel Item#	Spacing / Capacity
#38570	#38570-SS	3" / 9 Pans
#38571	#38571-SS	4" / 7 Pans

Universal Cart for Crisping Baskets
All Welded Construction
Overall Dimensions: 42.25"H x 24.25"W x 68.5"D

Aluminum Item#	Stainless Steel Item#	Spacing / Shelves
#5379	#5379-SS	11" / 5 Shelves

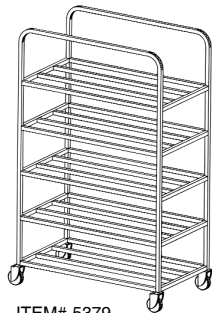

ITEM# 5379

Caster Upgrade Options:

Add (-HGF) suffix to Item # for 5" Plate Caster
 Add (-HJM) suffix to Item # for 5" Stem Caster

Replacement casters (Set of 4):

Item #1266	4" wheel
Item #2208	5" wheel
Item #9021	4" wheel
Item #9021-5	5" wheel



ITEM #1266 (4")
 ITEM #2208 (5")



ITEM #9021-1063 (4")
 ITEM #9021-1063-5 (5")

- SPECIFICATIONS:** Heavy duty tubular frame.
- All heli-arc welded construction.
 - Rolls easily on two 5" swivel and two 5" rigid casters.
 - Shipped set up, ready for use.
 - Call factory for quotes on your custom needs.

*Additional Options: See Page 44 & 45

LUG CARTS



END LOAD



ITEM# 10492



ITEM# 10491



ITEM #9021-1063 (4")
 ITEM #9021-1063-5 (5")



ITEM# 10493



ITEM# 10494

Ideal for Preparation, Transportation & Storage
All Welded Aluminum Construction
Overall Dimensions: 42.25"H x 24.25"W x 68.5"D

Item#	Dimensions	Spacing / Capacity
#10491	19"Hx16"Wx25"D	1 Lug*
#10492	33"Hx19"Wx25"D	10" / 2 Lugs*
#10493	41"Hx19"Wx27"D	10" / 3 Lugs*
#10494	71"Hx19"Wx27"D	10" / 6 Lugs*

*Lugs sold separately. Units also Available in Stainless Steel.

Polyethylene Lugs 16"x25"

Item#	Description
#9689	Gray Lug
#9689-WH	White Lug
#9690	Gray Lug Cover
#9690-WH	White Lug Cover

SPECIFICATIONS:

- Heavy duty tubular construction, all heli-arc welded.
- Rolls easily on 4" or 5" casters.
- Shipped set up, ready for use.
- Call factory for quotes on your custom needs.

*Additional Options: See Page 44 & 45

The photos are from actual production pieces and represent typical configurations. Actual final product may differ from photos shown. The specifications may change without prior notice.



POLY BOX RACKS



Ideal for Transporting Food Boxes with One Rack
All Welded Aluminum Construction
End Load 4" Plate Casters

Item#	Dimensions	Spacing/Capacity
#38580	69-1/2"H x 21"W x 26"D	7-1/2" - 08 Runners*
#38581	70"H x 21"W x 26"D	3-1/2" - 16 Runners*
#38582	71"H x 21"W x 26"D	5" - 12 Runners*

SPECIFICATIONS: Heavy duty tubular frame.

- All heli-arc welded construction.
- Accommodates 18"x26" and 18"x13" plastic food boxes with or without covers manufactured by Cambro®, Carlisle®, Continental® or Rubbermaid®.
- Rolls easily on 4" or 5" casters. Shipped set up, ready for use.
- Rack capacity is determined by depth of the box.
- Unique "C" channel design holds boxes securely, even when partially pulled out.
- Call factory for quotes on your custom needs.

*Additional Options: See Page 44 & 45



ITEM# 38581

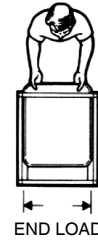

ITEM #1266 (4")
ITEM #2208 (5")

Caster Upgrade Options:

Add (-HGF) suffix to Item # for 5" Plate Caster

Replacement casters (Set of 4):

Item #1266 4" wheel

Item #2208 5" wheel

PLATTER CARTS

Ideal for meat, deli and produce departments.
All Welded Construction Stem Casters

Aluminum Item#	Stainless Steel Item#	Dimensions	Spc/Cap/Size
#10498	#10509	43"H x 13"W x 26"D	6" - 06 - 10"Trays*
#10499	#10510	43"H x 15"W x 26"D	6" - 06 - 12"Trays*
#10500	#10511	43"H x 20"W x 26"D	6" - 06 - 18"Trays*
#10501	#10512	67"H x 13"W x 26"D	6" - 10 - 10"Trays*
#10502	#10513	67"H x 15"W x 26"D	6" - 10 - 12"Trays*
#10503	#10514	67"H x 20"W x 26"D	6" - 10 - 18"Trays*
#10504	#10515	67"H x 13"W x 26"D	5" - 12 - 10"Trays*
#10505	#10516	67"H x 15"W x 26"D	5" - 12 - 12"Trays*
#10506	#10517	67"H x 20"W x 26"D	5" - 12 - 18"Trays*

Utility Platter Carts. Serve as a mobile cutting station with a removable poly work top.

Aluminum Item#	Stainless Steel Item#	Dimensions	Spc/Cap/Size
#10507	#10518	37"H x 15"W x 26"D	6" - 5 - 12"Trays*
#10508	#10519	37"H x 20"W x 26"D	6" - 5 - 18"Trays*

*Platters Sold Separately.



ITEM# 10501

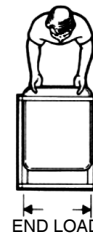

ITEM #9021 (4")
ITEM #9021-5 (5")

SPECIFICATIONS:

- Heavy duty tubular construction, all heli-arc welded.
- Rolls easily on 4" or 5" casters.
- Shipped set up, ready for use.
- Call factory for quotes on your custom needs.

Caster Upgrade Options:

Add (-HJM) suffix to Item # for 5" Stem Caster

Replacement casters (Set of 4):

Item #9021 4" wheel

Item #9021-5 5" wheel

The photos are from actual production pieces and represent typical configurations. Actual final product may differ from photos shown. The specifications may change without prior notice.



PIZZA PAN RACKS



**Heavy Duty All Welded Construction
Aluminum Plate Casters
End Load - Single Capacity**

Item#	Dimensions	Spc/Cap
#23239	34"H x 22"W x 20"D	2" / 12 Pans
#23239-26	62-1/2"H x 22"W x 20"D	2" / 26 Pans

Caster Upgrade Options:

Add (-HGF) suffix to Item # for 5" Plate Caster
Add (-HJM) suffix to Item # for 5" Stem Caster

Replacement casters (Set of 4):

Item #1266 4" wheel plate casters
Item #2208 5" wheel plate casters
Item #9021 4" wheel stem casters
Item #9021-5 5" wheel stem casters

*Additional Options: See Pg. 44 & 45



ITEM #1266 (4")
ITEM #2208 (5")

CAN STORAGE RACKS



**Inclined Can Guides Provide Easy Access &
Facilitate Stock Rotation when Loaded from Rear.
Heavy Duty All Welded Aluminum Construction.**

Stationary

Item#	Dimensions	Capacity
#19215-9	76"Hx25-1/2"Wx35"D	160 - #10 Cans
or		216 - # 5 Cans
#19215-4*	41"Hx25-1/2"Wx35"D	72 - #10 Cans
or		96 - # 5 Cans
#19215-3*	35"Hx25-1/2"Wx35"D	54 - #10 Cans
or		72 - # 5 Cans

Mobile

Item#	Dimensions	Capacity
#19215-9-PC	76"Hx25-1/2"Wx35"D	160 - #10 Cans
or		216 - # 5 Cans
#19215-4-PC*	41"Hx25-1/2"Wx35"D	72 - #10 Cans
or		96 - # 5 Cans
#19215-3-PC*	35"Hx25-1/2"Wx35"D	54 - #10 Cans
or		72 - # 5 Cans

* Add suffix to item number for required work top material:
(-PT) for Poly Top, (-ST) for Stainless Steel, (-AT) for Aluminum

Replacement casters (Set of 4):

Item #1266 4" wheel

*Additional Options: See Pg. 44 & 45

SPECIFICATIONS: Heavy duty tubular frame.

- Stainless Steel heli-arc welded construction.
- Call factory for quotes on your custom needs.

ROTISSERIE CHICKEN SPIT RACKS



**Heavy Duty All Welded Construction
Stainless Steel - Plate Casters and Drip Pan**

Item#	Description
#10654	Hickory Style Rotisserie Spit Rack
#10654-AS	Alto Shaam Style Rotisserie Spit Rack
#10654-HR	Hobart Style Rotisserie Spit Rack

Replacement casters (Set of 4):

Item #1266 4" wheel

*Additional Options: See Pg. 44 & 45

SPECIFICATIONS: Heavy duty tubular frame.

- Stainless Steel heli-arc welded construction.
- Call factory for quotes on your custom needs.

The photos are from actual production pieces and represent typical configurations. Actual final product may differ from photos shown. The specifications may change without prior notice.



WIRE TREE RACKS



Ideal for application desiring flexible load pattern
Heavy Duty Stainless Steel Construction - Plate Casters
Overall Dimensions: 72"H x 24"W

Single Item#	Depth	Pan Cap	Double Item#	Depth	Pan Cap
#22318-S25	22"	25	#22318-D25	42"	50
#22318-S18	22"	18	#22318-D18	42"	36
#22318-S14	22"	14	#22318-D14	42"	28
#22318-S11	22"	11	#22318-D11	42"	22
#22318-S09	22"	9	#22318-D09	42"	18

SPECIFICATIONS: Heavy duty tubular frame.

- All stainless steel heli-arc welded construction.
- Will accommodate various pan sizes.
- Can be loaded from three different sides.
- Rolls easily on 4" or 5" casters. Shipped set up, ready for use.
- Call factory for quotes on your custom needs.



ITEM# 22318-

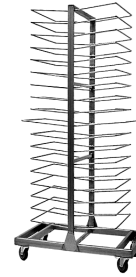

ITEM# 22318-D18



ITEM #1266 (4")
ITEM #2208 (5")

Caster Upgrade Options:

Add (-HGF) suffix to Item # for 5" Plate Caster

Replacement casters (Set of 4):

Item #1266 4" wheel

Item #2208 5" wheel

*Additional Options: See Pg. 44 & 45

PAN WASHER RACKS

Ideal for washing pans in commercial rack washers
Made from heavy duty 304 series stainless steel material
All welded construction with bolt on plate casters
Available in different sizes and configurations.

Item#	Dimensions	Spacing/Capacity
#8366	73-1/4"H x 40"W x 30-1/4"D	3-1/2" / 27 Pans

SPECIFICATIONS: Heavy duty angle frame.

- All heli-arc welded construction.
- Will accommodate various pan sizes.
- Can be loaded from different sides.
- Rolls easily on 4" casters. Shipped set up, ready for use.
- Call factory for quotes on your custom needs.

Replacement casters (Set of 4):

Item #1266 4" wheel

*Additional Options: See Pg. 44 & 45



ITEM #8366



ITEM #1266 (4")

TRAY DRYING RACKS

Tray Drying Racks are ideal for schools, cafeterias, correctional, & institutional facilities. Fully welded and provides convenient and accessible storage. Easy air circulation & shorter drying times.
Plate Casters - Dimensions: 63-3/4"W x 28"D

Aluminum Item#	Height	Pan Cap	Tray Levels	Angle Spacing
#39000	50-1/2"	80	2	1-1/2"
#39001	50-1/2"	40	2	2-3/4"
#39002	74-1/2"	120	3	1-1/2"
#39003	74-1/2"	60	3	2-3/4"

SPECIFICATIONS:

- Heavy duty aluminum tubular construction, all heli-arc welded.
- Welded angle pan slides.
- Will accommodate 18"x13" trays, 18"x26" trays.
- Two 18"x13" pans per slide.
- Rolls easily on 4" or 5" casters.
- Shipped set up, ready for use.
- Call factory for quotes on your custom needs.



ITEM# 39002



ITEM #1266 (4")
ITEM #2208 (5")

Caster Upgrade Options:

Add (-HGF) suffix to Item # for 5" Plate Caster

Replacement casters (Set of 4):

Item #1266 4" wheel

Item #2208 5" wheel

*Additional Options: See Pg. 44 & 45

The photos are from actual production pieces and represent typical configurations. Actual final product may differ from photos shown. The specifications may change without prior notice.



TRUCKS - STANDS & DOLLIES



ITEM# 6715
ITEM# 10495



ITEM# 6628
ITEM# 10496

Plate Casters - All Welded Construction Heavy Duty Angle Frame

Aluminum Item#	Stainless Steel Item#	Size	Description
#10495	#6715	41"H x 19"W x 27"D	Pan Dolly w / Handle
#10496	#6628	28"H x 21.5"W x 28"D	3-Sided Pan Truck
#10497	#2083	28"H x 21.5"W x 28"D	4-Sided Pan Truck
#7729	#7729-S	7"H x 19"W x 27"D	Pan Dolly



ITEM# 2083
ITEM# 10497



ITEM# 7729-S
ITEM# 7729

Plate Casters - All Welded Construction Heavy Duty Tubular Frame

Aluminum Item#	Stainless Steel Item#	Size	Description
#2251		47"H x 19.5"W x 27.5"D	Proofing Board Truck
#10496T	#6628T	47.5"H x 21.5"W x 28.5"D	Pan Truck w / Shelf
#10496THD		47.5"H x 22"W x 29"D	Pan Truck Heavy Duty
#10497T	#2083T	33.5"H x 21.5"W x 28.5"D	Pan Truck w / Shelf
#10497THD		33.5"H x 22"W x 29"D	Pan Truck w / Shelf HD
#10495DBL	#10495SDBL	40"H x 39.5"W x 29"D	Double Pan Truck



ITEM# 2251



ITEM# 6628T
ITEM# 10496T
ITEM# 10496THD

Stem Casters - All Welded Construction Heavy Duty Angle Frame

Aluminum Item#	Stainless Steel Item#	Size	Description
#38583		7.12"Hx21.875"Wx26.625"D	Bread Pan Dolly
#5381		8.00"Hx27"Wx19"D	Meat Dolly
#21375	#21375-S	12.5"Hx20.5"Wx26.5"D	Chicken Dolly
#38584		8.12"Hx26.75"Wx29.12"D	Univ Bread Pan Dolly
	#20120		Optional Handle



ITEM# 2083T
ITEM# 10497T
ITEM# 10497THD



ITEM# 10495SDBL
ITEM# 10495DBL



ITEM# 38583



ITEM# 38584

SPECIFICATIONS:

- Heavy duty angle or tubular construction, all heli-arc welded.
- Will accommodate 18"x26" trays, 18"x26" proofing boards or 17"x25" fryer screens.
- Rolls easily on 4" or 5" casters.
- Shipped set up, ready for use.
- Call factory for quotes on your custom needs.

Caster Upgrade Options:

Add (-HGF) suffix to Item # for 5" Plate Caster
Add (-HJM) suffix to Item # for 5" Stem Caster

Replacement casters (Set of 4):

- Item #1266 4" wheel
- Item #2208 5" wheel
- Item #9021 4" wheel
- Item #9021-5 5" wheel

*Additional Options: See Pg. 44 & 45



ITEM# 5381



ITEM# 21375



ITEM #1266 (4")
ITEM #2208 (5")



ITEM #9021 (4")
ITEM #9021-5 (5")

Sheet Pan Trucks & Dollies

The photos are from actual production pieces and represent typical configurations. Actual final product may differ from photos shown. The specifications may change without prior notice.



MOBILE DUNNAGE RACKS



Mobile Dunnage Racks provide a convenient mobile solution for transporting cartons, packages, and other material. Move heavier loads with ease while maximizing space. Optional Handle must be ordered separately.

Plate Casters - All Welded Aluminum Construction Heavy Duty - Weight Capacity: 1200 lbs

Dimensions: 8"H x 20"W

Item#	Length
#38400	24"
#38401	30"
#38402	36"
#38403	42"
#38404	48"
#38405	60"

Handle for 20"W Units Above
#38406

Dimensions: 8"H x 24"W

Item#	Length
#38410	24"
#38411	30"
#38412	36"
#38413	42"
#38414	48"
#38415	60"

Handle for 24"W Units Above
#38416



ITEM# 38400

Replacement casters (Set of 4):

Item #2886 5" wheel

Item #2886-RG 5" wheel

*Additional Options: See Pg. 44 & 45



ITEM #2886



ITEM #2886-RG

SPECIFICATIONS: Heavy duty tubular frame.

- All heli-arc welded construction.
- Rolls easily on two 5" swivel and two 5" rigid casters.
- Shipped set up, ready for use.
- Call factory for quotes on your custom needs.

STATIONARY DUNNAGE RACKS

Dunnage Racks - Used as a Pallet Rack, Cooler Storage Rack, Storage Shelving, or Cooler Shelving.

Store heavier loads with ease while maximizing space.

Heavy Duty - All Welded Tubular Construction

Aluminum

Item#	Stainless Steel Item#	Dimensions	Weight Cap
RDTA-203612	RDTS-203612	20"x36"x12"	1500
RDTA-204812	RDTS-204812	20"x48"x12"	1800
RDTA-206012	RDTS-206012	20"x60"x12"	2000
RDTA-243612	RDTS-243612	24"x36"x12"	1500
RDTA-244812	RDTS-244812	24"x48"x12"	1800
RDTA-246012	RDTS-246012	24"x60"x12"	2000
RDTA-184808	RDTS-184808	18"x48"x8"	1800
RDTA-203608	RDTS-203608	20"x36"x8"	1500
RDTA-204808	RDTS-204808	20"x48"x8"	1800
RDTA-206008	RDTS-206008	20"x60"x8"	2000
RDTA-243608	RDTS-243608	24"x36"x8"	1500
RDTA-244808	RDTS-244808	24"x48"x8"	1800
RDTA-246008	RDTS-246008	24"x60"x8"	2000

Heavy Duty - All Welded Tube/Channel Construction

Aluminum

Item#	Stainless Steel Item#	Dimensions	Weight Cap
RDCA-203612	RDCA-203612	20"x36"x12"	1500
RDCA-204812	RDCA-204812	20"x48"x12"	1800
RDCA-206012	RDCA-206012	20"x60"x12"	2000
RDCA-243612	RDCA-243612	24"x36"x12"	1500
RDCA-244812	RDCA-244812	24"x48"x12"	1800
RDCA-246012	RDCA-246012	24"x60"x12"	2000
RDCA-203608	RDCA-203608	20"x36"x8"	1500
RDCA-204808	RDCA-204808	20"x48"x8"	1800
RDCA-206008	RDCA-206008	20"x60"x8"	2000
RDCA-243608	RDCA-243608	24"x36"x8"	1500
RDCA-244808	RDCA-244808	24"x48"x8"	1800
RDCA-246008	RDCA-246008	24"x60"x8"	2000

Heavy Duty - All Welded Gusset Legs Construction

Aluminum

Item#	Stainless Steel Item#	Dimensions	Weight Cap
RDGA-203612	RDGS-203612	20"x36"x12"	1500
RDGA-204812	RDGS-204812	20"x48"x12"	1800
RDGA-206012	RDGS-206012	20"x60"x12"	2000
RDGA-243612	RDGS-243612	24"x36"x12"	1500
RDGA-244812	RDGS-244812	24"x48"x12"	1800
RDGA-246012	RDGS-246012	24"x60"x12"	2000



ITEM# RDTA-243612
ITEM# RDTS-243612



ITEM# RDCA-243612
ITEM# RDCA-243612

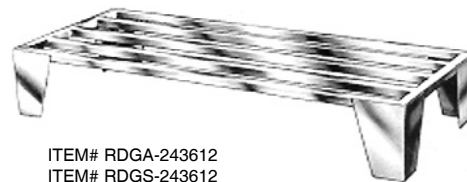

ITEM# RDGA-243612
ITEM# RDGS-243612

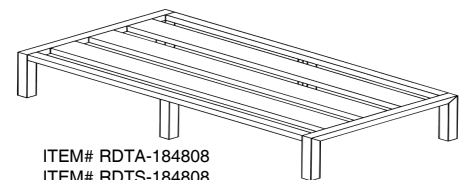

ITEM# RDTA-184808
ITEM# RDTS-184808

SPECIFICATIONS:

- Heavy Duty - All heli-arc welded construction.
- Shipped set up, ready for use.
- Call factory for quotes on your custom needs.



The photos are from actual production pieces and represent typical configurations. Actual final product may differ from photos shown. The specifications may change without prior notice.

UTILITY CARTS



ITEM #20655



ITEM #20656-G

U-Boat Cart with Removable Handles
Heavy Duty Welded Steel Construction
Four Swivel and Two Rigid Casters

Item#	Color	Dimensions	Bed Height
#20655	Green	61.25"H x 18"L x 48"W	9-11/16"

Two Tier Tubular Deck Cart
Heavy Duty Welded Steel Construction
Two Rigid and Two Swivel Casters

Item#	Color	Dimensions	Bed Height
#20656-G	Green	42"H x 18"W x 40"D	42"
#20656-B	Blue	42"H x 18"W x 40"D	42"



ITEM #20767

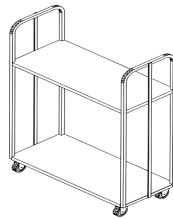

ITEM #5385

Produce Return Cart
Heavy Duty Welded Steel Construction
Two Rigid and Two Swivel Casters

Item#	Color	Dimensions	Shelves / Spc
#20767	Blue	65"H x 18"W x 60"D	5 / 10.375"

Solid Two Tier Stock Cart
Heavy Duty Welded Steel Construction
Two Rigid and Two Swivel Casters w/Brakes

Item#	Color	Dimensions	Shelves / Spc
#5385	Blue	44"D x 20"W x 65-5/8"H	2 / 41"

Solid Two Tier Utility Cart
Heavy Duty Welded Stainless Steel Construction
Two Rigid and Two Swivel Casters w/Brakes

Item#	Color	Dimensions	Shelves / Spc
#5383	Natural	40"H x 20"W x 40"D	2 / 18"

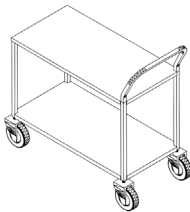

ITEM #5383

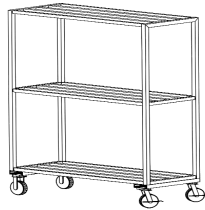

ITEM #20666-3

Fixed Channel Shelving Aluminum Cart
Heavy Duty All Welded Construction
Two Rigid and Two Swivel Casters w/Brakes

Item#	Color	Dimensions	Shelves / Spc
#20666-2	Natural	60"H x 20"W x 48"D	2 / 48.25"
#20666-3	Natural	60"H x 20"W x 48"D	3 / 23.375"

Replacement casters (Set of 4):
 Item #1266 4" wheel plate casters
 Item #1266-RGD 4" wheel rigid plate casters



ITEM #1266 (4")



ITEM #1266-RGD (4")

SPECIFICATIONS:

- Heavy duty all heli-arc welded construction.
- Rolls easily on 4" and 6" casters.
- Shipped set up, ready for use.
- Call factory for quotes on your custom needs.

*Additional Options: See Page 44 & 45

Utility Carts

The photos are from actual production pieces and represent typical configurations. Actual final product may differ from photos shown. The specifications may change without prior notice.



MIXER BOWL STANDS & LIFTS



BAKER PRO SERIES

Mixing Bowl Stand - Heavy Duty

Overall Dimensions: 27-1/2"W x 27-1/2"D x 30-1/4"H

Item#	Ring ID
#7632-18	18-1/4"
#7632-20	20-1/4"
#7632-22	22-7/8"

EZ Moving and Depositing at Standing Height

- Roll Heavy Mixing Bowls Easily on 4" Casters
- Equipped with 4 Caster Brakes
- Aluminum Heavy Duty All Welded Construction
- Optional 5" Casters and Corner Bumpers Available
- Note: Mixing Bowls not Included



ITEM #7632-20

Tilting Mixer Bowl Stand - Heavy Duty

Overall Dimensions: 28-7/16"W x 26-3/8"D x 32-1/4"H

Item#	Bowl Capacity	Pouring Ht.
#7632-MOD1-60	60 - Qt.	15"
#7632-MOD1-80	80 - Qt.	15"
#7632-MOD1-140	140 - Qt.	15"

The Bowl Easily Tilts for Depositing Mixed Batter

- Roll & Tilt Heavy Mixing Bowls Easily on 4" Casters
- Equipped with 4 Caster Brakes
- Aluminum Heavy Duty Base All Welded Construction
- Stainless Steel Heavy Duty Bowl Holding Mechanism
- Stainless Steel Heavy Duty Handle
- Optional 5" Casters and Corner Bumpers Available
- Different Pouring Height Available Upon Request
- Note: Mixing Bowls not Included



ITEM #7632-MOD1-80

Tilting Mixer Bowl Lift - Heavy Duty

Conveniently Lift or Lower the Bowl at the Touch of a Switch
*Lifting Capacity 450 lbs. Maximum Pouring Height 46" & (62)"**
Lifting Range 59" & (76)", Battery Charge Life 120-150 Cycles*

Item#	Overall Dimensions	Bowl Capacity	Pouring Ht.
#DB-80	35"W x 43"L x 44"H	80 - Qt.	46"
#DB-140	37-1/2"W x 44-1/2"L x 45"H	140 - Qt.	46"
#DL-80*	35-1/2"W x 56-1/2"L x 45"H	80 - Qt.	62"
#DL-80E*	35-1/2"W x 58"L x 48"H	80 - Qt.	65" (68" max)
#DL-140*	35-1/2"W x 56-1/2"L x 45"H	140 - Qt.	62"
#UT-140	38"W x 22"L x 33"H	140 - Qt.	46"
#BA-60	Bowl Adapter	60 to 80 - Qt.	
#BA-80	Bowl Adapter	80 to 140 - Qt.	

The Bowl Easily Lifts & Tilts for Depositing Mixed Batter or Dough *Ergonomically designed to reduce stress and injuries caused by lifting heavy mixer bowls. *Equipped with power tilt for pouring.*

- Fits Hobart® Classic Bowl Sizes 140, 80 & 60 Quart
- Available for Hobart Legacy models using adapter ring on bowls
- Finished in Food Grade Durable Epoxy Paint
- Key Pivot Pins are Stainless Steel
- All Bearings Pre-Lubricated for Life. Sealed Ball Type, Bronze Oilite Bushings and Iron Oilite.
- Note: Mixing Bowls not Included



ITEM #DB-80
ITEM #DB-140



ITEM #1266 (4")
ITEM #2208 (5")



ITEM #7409-TS

Caster Upgrade Options:

Add (-HGF) suffix to Item # for 5" Plate Caster

Replacement casters (Set of 4):

- Item #1266 4" wheel
- Item #2208 5" wheel
- Item #7409-TS 5" wheel

**Additional Options: See Pg. 44 & 45*



ITEM #UT-140

The photos are from actual production pieces and represent typical configurations. Actual final product may differ from photos shown. The specifications may change without prior notice.



BULK MOVERS



ITEM #1266 (4")
ITEM #2208 (5")

ITEM #23429-6WH
ITEM #23429-8WH

Caster Upgrade Options:
Add (-HGF) suffix to Item # for 5" Plate Caster

Replacement casters (Set of 4):

Item #1266 4" wheel

Item #2208 5" wheel

*Additional Options: See Pg. 44 & 45



ITEM #20140-3WH

ITEM #20140-6BL
ITEM #20140-8BL

ITEM #20140-6WH
ITEM #20140-8WH

Bulk Movers are Ideal for Meat, Produce, Fish and Deli Departments. Very useful for Food Preparation and Backroom Processing. Tub Color provides efficient Department Management: Blue for Fish, Red for Meat, White for Produce. Removable sanitary polyethylene tubs are washable and steam cleanable to maintain proper sanitation.

Aluminum - Stem Casters

Item#	Description	Dimensions
#23429-3B	Frame only 3 Bushel	19"Wx30"Lx28-1/2"H
#23429-6B	Frame only 6 Bushel	22"Wx33"Lx28-1/2"H
#23429-8B	Frame only 8 Bushel	22"Wx38-1/2"Lx28-1/2"H
#23429-3B-XX*	Bulk Mover 3 Bushel	19"Wx30"Lx32"H
#23429-6B-XX*	Bulk Mover 6 Bushel	22"Wx33"Lx36"H
#23429-8B-XX*	Bulk Mover 8 Bushel	22"Wx40"Lx32"H

Stainless Steel - Stem Casters

Item#	Description	Dimensions
#23429S-3B	Frame only 3 Bushel	19"Wx30"Lx28-1/2"H
#23429S-6B	Frame only 6 Bushel	22"Wx33"Lx28-1/2"H
#23429S-8B	Frame only 8 Bushel	22"Wx38-1/2"Lx28-1/2"H
#23429S-3B-XX*	Bulk Mover 3 Bushel	19"Wx30"Lx32"H
#23429S-6B-XX*	Bulk Mover 6 Bushel	22"Wx33"Lx36"H
#23429S-8B-XX*	Bulk Mover 8 Bushel	22"Wx40"Lx32"H

* Add suffix to item number for required tub color:

(-WH) for White, (-BL) for Blue, (-GY) for Gray, (-RD) for Red.

Tubs

Item#	Description	Dimensions
#20140-3WH	Tub only 3 Bushel White	19"Wx30"Lx12"H
#20140-6WH	Tub only 6 Bushel White	22"Wx32"Lx21"H
#20140-6BL	Tub only 6 Bushel Blue	22"Wx32"Lx21"H
#20140-6GY	Tub only 6 Bushel Gray	22"Wx32"Lx21"H
#20140-6RD	Tub only 6 Bushel Red	22"Wx32"Lx21"H
#20140-8WH	Tub only 8 Bushel White	22"Wx40"Lx21"H
#20140-8BL	Tub only 8 Bushel Blue	22"Wx40"Lx21"H
#20140-8GY	Tub only 8 Bushel Gray	22"Wx40"Lx21"H
#20140-8RD	Tub only 8 Bushel Red	22"Wx40"Lx21"H

TRAYS / PLATTERS & RETARDING BOXES

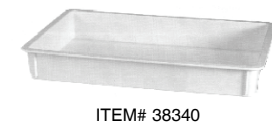

ITEM# 38340

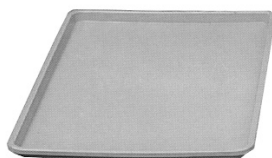

ITEM# 1200-PL



ITEM# 23318

Dough Retarding Boxes

Item#	Description	Dimensions
#38340	Dough Retarding Box	18" x 26" x 3.5"
#38341	Cover f/ Item #38340	

Plastic Trays / Platters and Bus Boxes

Item#	Description	Dimensions
#1200-PL	Display Tray - White	18" x 26"
#1364-PL	Display Tray - White	9" x 26"
#5027-PL	Display Tray - Yellow	18" x 26"
#8417-PL	Display Tray - Yellow	9" x 26"

Platters

Item#	Description	Dimensions
#23317	Meat Platter - White	18" x 26"
#23318	Meat Platter - White	12" x 30"
#23319	Meat Platter - White	12" x 24"
#23320	Meat Platter - White	10" x 30"
#23321	Meat Platter - White	9" x 26"

Proofing Boards

Item#	Description	Dimensions
#6767	Proofing Board	18" x 26"

Bus Boxes

Item#	Description	Dimensions
#23322	Bus Box - Gray	15-3/4 x 21-3/4

The photos are from actual production pieces and represent typical configurations. Actual final product may differ from photos shown. The specifications may change without prior notice.



CUSTOM FOOD EQUIPMENT



16 Ga. All Welded Stainless Steel Construction Heavy Duty 1.5" Tubular Frame w/Adj Feet

Dimensions: 30" Wide x 35" High

304 SS Top	1.75" Wood Top	1" Poly Top	Length
Item#	Item#	Item#	
TSS3048	TWS3048	TPS3048	4'
TSS3060	TWS3060	TPS3060	5'
TSS3072	TWS3072	TPS3072	6'
TSS3084	TWS3084	TPS3084	7'
TSS3096	TWS3096	TPS3096	8'



ITEM #TSS3048
ITEM #TSS3648

Optional Construction:
2"-4" Frame Size Materials
Round or Square Frame
.063"-.188" Surface Materials

16 Ga. All Welded Stainless Steel Construction Heavy Duty 1.5" Tubular Frame w/Adj Feet

Dimensions: 36" Wide x 35" High

304 SS Top	1.75" Wood Top	1" Poly Top	Length
Item#	Item#	Item#	
TSS3648	TWS3648	TPS3648	4'
TSS3660	TWS3660	TPS3660	5'
TSS3672	TWS3672	TPS3672	6'
TSS3684	TWS3684	TPS3684	7'
TSS3696	TWS3696	TPS3696	8'



ITEM #TWS3048
ITEM #TWS3648



ITEM #9375

Table Options:

304 16 Ga. Stainless Steel Undershef

30" Wide	36" Wide	Length
Item#	Item#	
#39060	#39070	4'
#39061	#39071	5'
#39062	#39072	6'
#39063	#39073	7'
#39064	#39074	8'



ITEM #TPS3048
ITEM #TPS3648



ITEM #9375-BR

1" Poly Top Replacement

30" Wide	36" Wide	Length
Item#	Item#	
#39080-P	#39090-P	4'
#39081-P	#39091-P	5'
#39082-P	#39092-P	6'
#39083-P	#39093-P	7'
#39084-P	#39094-P	8'

Replacement casters (Set of 4):

Item #9375 4" wheel

Item #9375-BR 4" wheel

*Additional Options: See Pg. 42 & 43

1.75" Maple Wood Top Replacement

30" Wide	36" Wide	Length
Item#	Item#	
#39080	#39090	4'
#39081	#39091	5'
#39082	#39092	6'
#39083	#39093	7'
#39084	#39094	8'



304 SS Drawer Self Closing, Hardware & Accessories

15"x18"	15"x20"	20"x20"	Description
Item#	Item#	Item#	
#38462	#39100	#39110	Drawer Covered Corners

Paper Holder 12"x5"x31"

#38460 Paper Holder

Platter Holder 30"x24"

#38461 Platter Holder

SPECIFICATIONS:

- Heavy Duty - All heli-arc welded construction.
- Shipped set up, ready for use.
- Call factory for quotes on your custom needs.

*Additional Options: See Pg. 44 & 45

Custom Tables Sinks & Make-up Units



The photos are from actual production pieces and represent typical configurations. Actual final product may differ from photos shown. The specifications may change without prior notice.

CUSTOM FOOD EQUIPMENT



HIGH QUALITY STAINLESS STEEL FOR THE COMMERCIAL KITCHEN

- CUSTOM DESIGNED WORK STATIONS
- KITCHEN PRODUCTS
- INSTALLATION
- FIELD SERVICE



ITEM# 38430

Specifically designed to accommodate counter-top cooking and warming equipment. Stands are built with a 1" lip up on 3 sides. Reinforced heavy duty solid 12 gauge aluminum top. Optional aluminum undershelf provides convenient storage space. Mobile units are equipped with four non-marking 4" stem type casters with brakes.

Equipment Stand - Stationary - Heavy Duty Aluminum 24" High w/1" Three Sided Lip

24" Wide		30" Wide		Length
No Shelf Item#	Undershelf Item#	No Shelf Item#	Undershelf Item#	
#38420	#38430	#38424	#38434	36"
#38421	#38431	#38425	#38435	48"
#38422	#38432	#38426	#38436	60"
#38423	#38433	#38427	#38437	72"

Equipment Stand - Mobile - Heavy Duty Aluminum 24" High w/1" Three Sided Lip

24" Wide		30" Wide		Length
No Shelf Item#	Undershelf Item#	No Shelf Item#	Undershelf Item#	
#38440	#38450	#38444	#38454	36"
#38441	#38451	#38445	#38455	48"
#38442	#38452	#38446	#38456	60"
#38443	#38453	#38447	#38457	72"

Custom Tables Sinks & Make-up Units



The photos are from actual production pieces and represent typical configurations. Actual final product may differ from photos shown . The specifications may change without prior notice.

BOAT RACKS & SHELVING



Heavy Duty - Boat Racks

All welded aluminum tubular construction

Table Mount		Wall Mount	
Item#	Item#	Item#	Dim
#38470	#38480		15"x36"
#38471	#38481		15"x48"
#38472	#38482		15"x60"
#38473	#38483		15"x72"
#38474	#38484		15"x96"
#38475	#38485		15"x102"
Ceiling "L" Mount		Ceiling "T" Mount	
#38486	#38488		15"x72"
#38487	#38489		15"x96"
Optional	Description		
#38488-D	Boat Rack Divider		

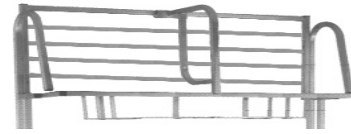

ITEM# 38472

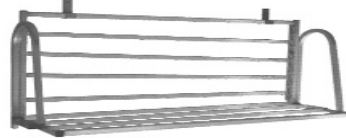

ITEM# 38482



ITEM# 38486

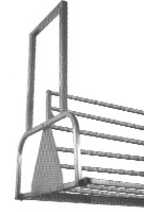

ITEM# 38488

Heavy Duty - T-Bar Shelves / Pot Racks

All welded aluminum construction

Table Mount		Wall Mount		Cap
Item#	Hooks	Item#	Dim	
#38490	6	#38493	20"x36"	700
#38491	7	#38494	20"x48"	600
#38492	8	#38495	20"x60"	500
		#38496	24"x60"	500

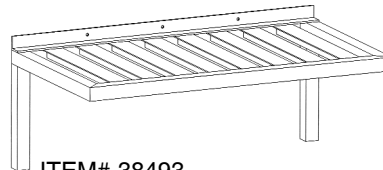

ITEM# 38493

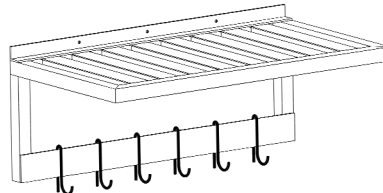

ITEM# 38490 Adjustable pot rack hooks slide easily into place to fit your needs.
ITEM# 23486 Additional Hooks

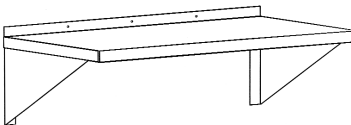

ITEM# 38510

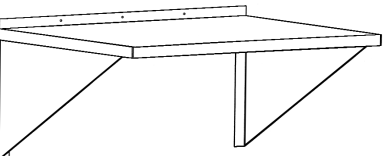

ITEM# 38522

Heavy Duty - Solid Wall Shelves

All welded aluminum construction

Wall Shelves		Microwave Shelves		Cap
Item#	Item#	Item#	Dim	
*#38510			12"x24"	300
*#38511			12"x36"	300
*#38512			12"x48"	225
*#38513			12"x60"	150
#38514			15"x24"	300
#38515			15"x36"	300
#38516			15"x48"	225
#38517			15"x60"	150
#38518		#38522	18"x24"	300
#38519			18"x36"	300
#38520			18"x48"	225
#38521			18"x60"	150
		#38523	24"x36"	300

*Also available in 18Ga. for lighter loads and smaller products.

SPECIFICATIONS:

- Heavy Duty - All heli-arc welded construction.
- Shipped set up, ready for use.
- Call factory for quotes on your stainless steel & custom needs.

Note: User should determine that wall material and method of mounting are suitable to support the shelves and their contents.



The photos are from actual production pieces and represent typical configurations. Actual final product may differ from photos shown. The specifications may change without prior notice.

OVEN STANDARD & NESTING RACKS

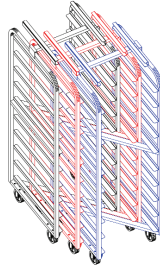

ITEM #6436-Z

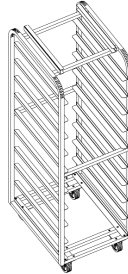

ITEM #6436

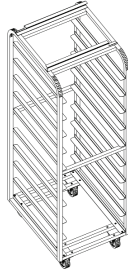

ITEM #4083

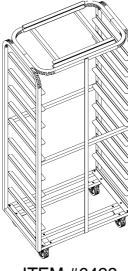

ITEM #6423

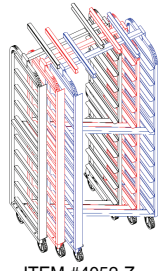

ITEM #4052-Z

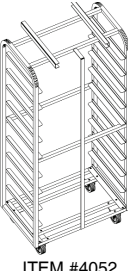

ITEM #4052

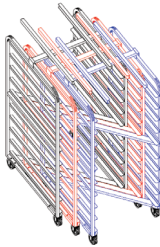

ITEM #9090-Z

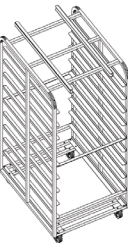

ITEM #4090

Caster Upgrade Options:

Add (-HIM) suffix to Item # for 5" HD Plate Caster



#6283-RULON1



#2310-GR

Replacement Plate Casters (Set of 4):

Item #2310-GR Plate Caster 4" wheel
Item #6283-RULON-1 HD Plate Caster 4" wheel

BAXTER STYLE OVEN RACKS

Single End Load for Single Oven

Overall Dimensions: 20-1/2"W x 26"D x 69-13/16"H

Aluminum	Stainless Steel	Spacing/Capacity
#6426	#6427	2" / 30
#7354	#7355	2.5" / 24
#6429	#6428	3" / 20
#6430	#6431	3.5" / 17
#6432	#6433	4" / 15
#6434	#6435	5" / 12
#6436	#6437	6" / 10
#6424	#6425	7" / 08

Single End Load for Double Oven

Overall Dimensions: 20-1/2"W x 26"D x 69-13/16"H

Aluminum	Stainless Steel	Spacing/Capacity
#4088	#4067	2" / 30
#4087	#4066	2.5" / 24
#2060	#4065	3" / 20
#4086	#4064	3.5" / 17
#4085	#4063	4" / 15
#4084	#4062	5" / 12
#4083	#4061	6" / 10
#4082	#4060	7" / 08

Single Side Load for Single Oven

Overall Dimensions: 28.5"W x 18"D x 69-13/16"H

Aluminum	Stainless Steel	Spacing/Capacity
#6411	#6410	2" / 30
#6413	#6412	2.5" / 24
#6415	#6414	3" / 20
#6417	#6416	3.5" / 17
#6419	#6418	4" / 15
#6421	#6420	5" / 12
#6423	#6422	6" / 10
#6409	#6408	7" / 08

Single Side Load for Double Oven

Overall Dimensions: 28-1/2"W x 18"D x 69-13/16"H

Aluminum	Stainless Steel	Spacing/Capacity
#4058	#4077	2" / 30
#4057	#4076	2.5" / 24
#4056	#4075	3" / 20
#4055	#4074	3.5" / 17
#4054	#4073	4" / 15
#4053	#4072	5" / 12
#4052	#4071	6" / 10
#4051	#4070	7" / 08

Double Side Load for Double Oven

Overall Dimensions: 28-1/2"W x 36"D x 69-13/16"H

Aluminum	Stainless Steel	Spacing/Capacity
#4095	#2238	2" / 30
#4094	#4081	2.5" / 24
#1890	#2237	3" / 20
#4093	#4080	3.5" / 17
#4092	#2036	4" / 15
#4091	#2040	5" / 12
#4090	#2041	6" / 10
#4089	#4079	7" / 08

* Add suffix (-Z) to item number for Z-Nesting rack order.

Available to fit most Foreign & Domestic Rack Ovens
Ideal for Retail, Wholesale, or Large Production Operations

SPECIFICATIONS:

- All Welded Construction
- Will accommodate 18"x26" trays
- Available With Heavy Duty Casters
- Custom Sizes & Designs Available
- Racks Shipped Fully Assembled Ready to Use

*Additional Options and Information: See Page 40, 44 & 45

Baxter Style Oven Standard & Nesting Racks



The photos are from actual production pieces and represent typical configurations. Actual final product may differ from photos shown. The specifications may change without prior notice.

OVEN STANDARD & NESTING RACKS

Dahlen & Gemini Style Oven Standard & Nesting Racks



DAHLEN / GEMINI ROLLER STYLE HANGING DEVICE

**Single End Load for Single Oven 20.5"W x 26"D x 65"H*

Aluminum	Stainless Steel	Spacing/Capacity
Item#	Item#	
#1035	#1107	2" / 27 Pans
#1034	#1106	2.5" / 21 Pans
#1033	#1105	3" / 18 Pans
#1032	#1104	3.5" / 15 Pans
#1031	#1103	4" / 13 Pans
#1030	#1102	4.5" / 12 Pans
#1029	#1101	5" / 11 Pans
#4349	#10464	5.5" / 10 Pans
#10450	#10465	6" / 09 Pans
#1028	#1100	6.5" / 08 Pans
#10451	10466	7" / 07 Pans

**Single End Load for Double Oven 20.5"W x 26"D x 74.25"H*

#1044	#1116	2" / 30 Pans
#1043	#1115	2.5" / 24 Pans
#1042	#1114	3" / 20 Pans
#1041	#1113	3.5" / 17 Pans
#1040	#1112	4" / 15 Pans
#1039	#1111	4.5" / 13 Pans
#1038	#1110	5" / 12 Pans
#1037	#1109	5.5" / 11 Pans
#1036	#1108	6" / 10 Pans
#10452	#10467	6.5" / 09 Pans
#10453	#10468	7" / 08 Pans

**Single Side Load for Single Oven 28.5"W x 18"D x 74.25"H*

#1454	#10479	2" / 30 Pans
#10454	#10478	2.5" / 24 Pans
#1455	#10477	3" / 20 Pans
#10455	#10476	3.5" / 17 Pans
#1524	#10475	4" / 15 Pans
#10456	#10474	4.5" / 13 Pans
#10457	#10473	5" / 12 Pans
#10458	#10472	5.5" / 11 Pans
#10459	#10471	6" / 10 Pans
#10460	#10470	6.5" / 09 Pans
#10461	#10469	7" / 08 Pans

**Double Side Load for Double Oven 28.5"W x 37"D x 74.25"H*

#1053	#1125	2" / 30 Pans
#1052	#1124	2.5" / 24 Pans
#1051	#1123	3" / 20 Pans
#1050	#1122	3.5" / 17 Pans
#1049	#1121	4" / 15 Pans
#1048	#1120	4.5" / 13 Pans
#1047	#1119	5" / 12 Pans
#1046	#1118	5.5" / 11 Pans
#1045	#1117	6" / 10 Pans
#10462	#10480	6.5" / 09 Pans
#10463	#10481	7" / 08 Pans

* Add suffix (-Z) to item number for Z-Nesting rack order.

Available to fit most Foreign & Domestic Rack Ovens

Ideal for Retail, Wholesale, or Large Production Operations

SPECIFICATIONS:

- All Welded Construction
- Will accommodate 18"x26" trays
- Available With Heavy Duty Casters
- Custom Sizes & Designs Available
- Racks Shipped Fully Assembled Ready to Use

**Additional Options: See Page 44 & 45*

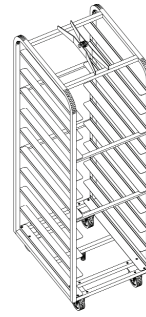

Item #10450



Item #10450-Z

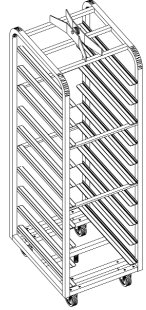

Item #1036

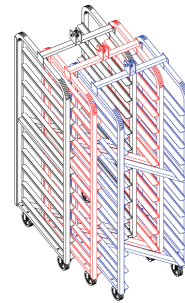

Item #1036-Z

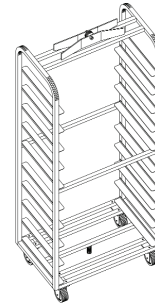

Item #10459

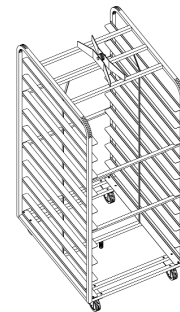

Item #1045

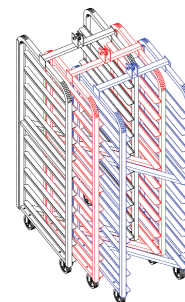

Item #1045-Z

Caster Upgrade Options:

Add (-HIM) suffix to Item # for 5" HD Plate Caster



#6283-RULON1



#2310-GR

Replacement Plate Casters (Set of 4):

Item #2310-GR

Plate Caster 4" wheel

Item #6283-RULON-1

HD Plate Caster 4" wheel

The photos are from actual production pieces and represent typical configurations. Actual final product may differ from photos shown. The specifications may change without prior notice.



OVEN STANDARD & NESTING RACKS

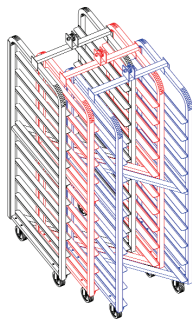

Item #7176-Z

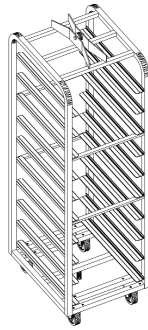

Item #7176

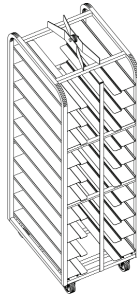

Item #7176-U

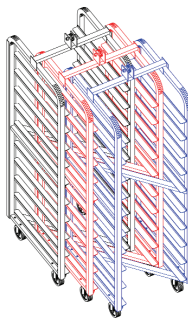

Item #8186-Z

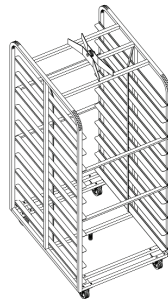

Item #8186

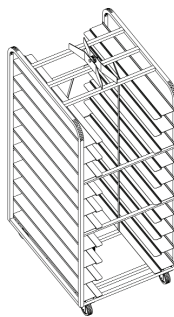

Item #8186-U

Caster Upgrade Options:

Add (-HIM) suffix to Item # for 5" HD Plate Caster



#6283-RULON1



#2310-GR

Replacement Plate Casters (Set of 4):

Item #2310-GR Plate Caster 4" wheel
Item #6283-RULON-1 HD Plate Caster 4" wheel

DAHLEN / GEMINI ROLLER STYLE HANGING DEVICE

*Single End Load f/ Single Rack Oven 20.5"Wx26"Dx72"H
Standard Shelves .63"H x 2"W

Aluminum	Item#	Stainless Steel	Item#	Spacing/Capacity
#7184	#7184	#8189	#8189	2" / 30 Pans
#7183	#7183	#8190	#8190	2.5" / 24 Pans
#7182	#7182	#8191	#8191	3" / 20 Pans
#7181	#7181	#8192	#8192	3.5" / 17 Pans
#7180	#7180	#8193	#8193	4" / 15 Pans
#7179	#7179	#8194	#8194	4.5" / 13 Pans
#7178	#7178	#8195	#8195	5" / 12 Pans
#7177	#7177	#8196	#8196	5.5" / 11 Pans
#7176	#7176	#8197	#8197	6" / 10 Pans
#8167	#8167	#8198	#8198	6.5" / 09 Pans
#8168	#8168	#8199	#8199	7" / 08 Pans

*Single End Load f/ Double Rack Oven 20.5"Wx26"Dx72"H
Universal Shelves .63"H x 5.75"W

#7181-U	#8192-U	3.5" / 17 Pans
#7180-U	#8193-U	4" / 15 Pans
#7179-U	#8194-U	4.5" / 13 Pans
#7178-U	#8195-U	5" / 12 Pans
#7177-U	#8196-U	5.5" / 11 Pans
#7176-U	#8197-U	6" / 10 Pans
#8167-U	#8198-U	6.5" / 09 Pans
#8168-U	#8199-U	7" / 08 Pans

*Double Side Load f/ Double Rack Oven 28.5"Wx37"Dx72"H
Standard Shelves .63"H x 2"W

#8169	#8200	2" / 30 Pans
#8170	#8201	2.5" / 24 Pans
#8180	#8202	3" / 20 Pans
#8181	#8203	3.5" / 17 Pans
#8182	#8204	4" / 15 Pans
#8183	#8205	4.5" / 13 Pans
#8184	#8206	5" / 12 Pans
#8185	#8207	5.5" / 11 Pans
#8186	#8208	6" / 10 Pans
#8187	#8209	6.5" / 09 Pans
#8188	#8210	7" / 08 Pans

*Double Side Load f/ Double Rack Oven 28.5"Wx37"Dx72"H
Universal Shelves .63"H x 5.75"W

#8181-U	#8203-U	3.5" / 17 Pans
#8182-U	#8204-U	4" / 15 Pans
#8183-U	#8205-U	4.5" / 13 Pans
#8184-U	#8206-U	5" / 12 Pans
#8185-U	#8207-U	5.5" / 11 Pans
#8186-U	#8208-U	6" / 10 Pans
#8187-U	#8209-U	6.5" / 09 Pans
#8188-U	#8210-U	7" / 08 Pans

*Add (-Z) to the end of the Item# for Nesting.

Available to fit most Foreign & Domestic Rack Ovens
Ideal for Retail, Wholesale, or Large Production Operations

SPECIFICATIONS:

- All Welded Construction
- Will accommodate 18"x26" trays
- Available With Heavy Duty Casters
- Custom Sizes & Designs Available
- Racks Shipped Fully Assembled Ready to Use

*Additional Options: See Page 44 & 45

Dahlen & Gemini Style Oven Standard & Nesting Racks



The photos are from actual production pieces and represent typical configurations. Actual final product may differ from photos shown. The specifications may change without prior notice.

OVEN STANDARD & NESTING RACKS



DAHLEN / GEMINI CHANNEL STYLE HANGING DEVICE

**Single Side Load f/ Single Rack Oven 28.5"Wx18"Dx69.8"H
Standard Shelves .63"H x 2"W*

Aluminum	Stainless Steel	Spacing/Capacity
Item# #7029	Item# #8222	2" / 30 Pans
#7030	#8223	2.5" / 24 Pans
#7031	#8224	3" / 20 Pans
#7032	#8225	3.5" / 17 Pans
#7033	#8226	4" / 15 Pans
#7034	#8227	4.5" / 13 Pans
#7035	#8228	5" / 12 Pans
#7036	#8229	5.5" / 11 Pans
#7037	#8230	6" / 10 Pans
#7038	#8231	6.5" / 09 Pans
#7039	#8232	7" / 08 Pans

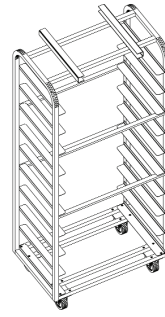

Item #7037

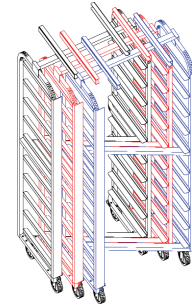

Item #7037-Z

**Single Side Load f/ Single Rack Oven 28.5"Wx18"Dx69.8"H
Universal Shelves .63"H x 5.75"W*

#7032-U	#8225-U	3.5" / 17 Pans
#7033-U	#8226-U	4" / 15 Pans
#7034-U	#8227-U	4.5" / 13 Pans
#7035-U	#8228-U	5" / 12 Pans
#7036-U	#8229-U	5.5" / 11 Pans
#7037-U	#8230-U	6" / 10 Pans
#7038-U	#8231-U	6.5" / 09 Pans
#7039-U	#8232-U	7" / 08 Pans

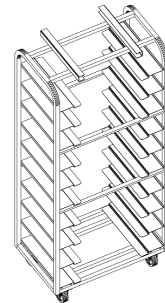

Item #7037-U

**Double Side Load f/ Double Rack Oven 28.5"Wx37"Dx69.8"H
Standard Shelves .63"H x 2"W*

#8211	#8233	2" / 30 Pans
#8212	#8234	2.5" / 24 Pans
#8213	#8235	3" / 20 Pans
#8214	#8236	3.5" / 17 Pans
#8215	#8237	4" / 15 Pans
#8216	#8238	4.5" / 13 Pans
#8217	#8239	5" / 12 Pans
#8218	#8240	5.5" / 11 Pans
#8219	#8241	6" / 10 Pans
#8220	#8242	6.5" / 09 Pans
#8221	#8243	7" / 08 Pans

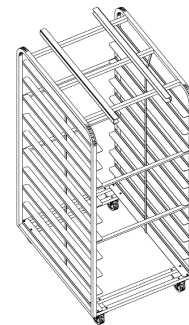

Item #8219

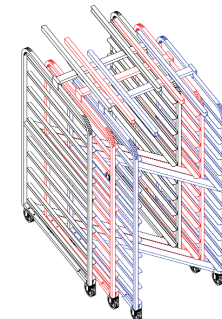

Item #8219-Z

**Double Side Load f/ Double Rack Oven 28.5"Wx37"Dx69.8"H
Universal Shelves .63"H x 5.75"W*

#8214-U	#8236-U	3.5" / 17 Pans
#8215-U	#8237-U	4" / 15 Pans
#8216-U	#8238-U	4.5" / 13 Pans
#8217-U	#8239-U	5" / 12 Pans
#8218-U	#8240-U	5.5" / 11 Pans
#8219-U	#8241-U	6" / 10 Pans
#8220-U	#8242-U	6.5" / 09 Pans
#8221-U	#8243-U	7" / 08 Pans

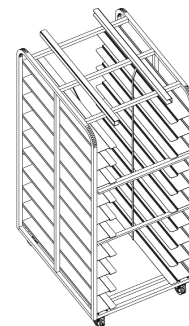

Item #8219-U

*Add (-Z) to the end of the Item# for Nesting.

Available to fit most Foreign & Domestic Rack Ovens
Ideal for Retail, Wholesale, or Large Production Operations

SPECIFICATIONS:

- All Welded Construction
- Will accommodate 18"x26" trays
- Available With Heavy Duty Casters
- Custom Sizes & Designs Available
- Racks Shipped Fully Assembled Ready to Use

*Additional Options: See Page 44 & 45

Caster Upgrade Options:

Add (-HIM) suffix to Item # for 5" HD Plate Caster



#6283-RULON1



#2310-GR

Replacement Plate Casters (Set of 4):

Item #2310-GR

Plate Caster 4" wheel

Item #6283-RULON-1

HD Plate Caster 4" wheel

The photos are from actual production pieces and represent typical configurations. Actual final product may differ from photos shown. The specifications may change without prior notice.



OVEN STANDARD & NESTING RACKS

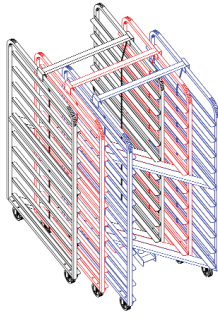

Item #8252-Z

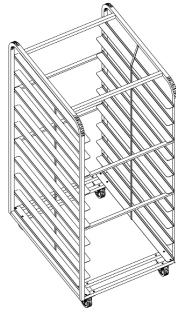

Item #8252

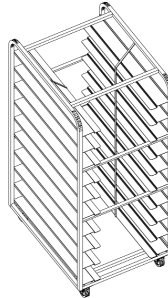

Item #8252-U

DAHLEN / GEMINI PLATFORM STYLE

**Double Side Load f/ Double Rack Oven 28.5"Wx37"Dx70.94"H
Standard Shelves .63"H x 2"W*

Aluminum	Item#	Stainless Steel	Item#	Spacing/Capacity
#8244		#8255		2" / 30 Pans
#8245		#8256		2.5" / 24 Pans
#8246		#8257		3" / 20 Pans
#8247		#8258		3.5" / 17 Pans
#8248		#8259		4" / 15 Pans
#8249		#8260		4.5" / 13 Pans
#8250		#8261		5" / 12 Pans
#8251		#8262		5.5" / 11 Pans
#8252		#8263		6" / 10 Pans
#8253		#8264		6.5" / 09 Pans
#8254		#8265		7" / 08 Pans

**Double Side Load f/ Double Rack Oven 28.5"Wx37"Dx70.94"H
Universal Shelves .63"H x 5.75"W*

#8247-U		#8258-U		3.5" / 17 Pans
#8248-U		#8259-U		4" / 15 Pans
#8249-U		#8260-U		4.5" / 13 Pans
#8250-U		#8261-U		5" / 12 Pans
#8251-U		#8262-U		5.5" / 11 Pans
#8252-U		#8263-U		6" / 10 Pans
#8253-U		#8264-U		6.5" / 09 Pans
#8254-U		#8265-U		7" / 08 Pans

*Add (-Z) to the end of the Item# for Nesting.

LUCKS STYLE OVEN RACKS

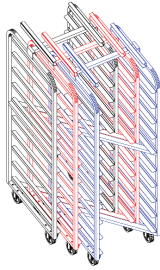

Item #10301-Z

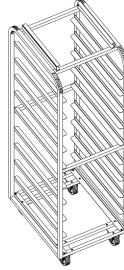

Item #10301

LUCKS CHANNEL STYLE HANGING DEVICE

**Single End Load f/ Single Rack Oven 20.5"Wx26"Dx70.75"H*

#10307		#10327		2" / 30 Pans
#10306		#10326		2.5" / 24 Pans
#10305		#10325		3" / 20 Pans
#10304		#10324		3.5" / 17 Pans
#10303		#10323		4" / 15 Pans
#10302		#10322		5" / 12 Pans
#10301		#10321		6" / 10 Pans
#10300		#10320		7" / 08 Pans

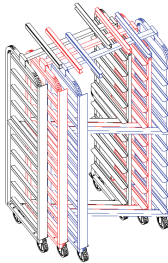

Item #10341-Z

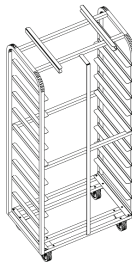

Item #10341

**Single Side Load f/ Double Rack Oven 28.5"Wx18"Dx70.75"H*

#10347		#10367		2" / 30 Pans
#10346		#10366		2.5" / 24 Pans
#10345		#10365		3" / 20 Pans
#10344		#10364		3.5" / 17 Pans
#10343		#10363		4" / 15 Pans
#10342		#10362		5" / 12 Pans
#10341		#10361		6" / 10 Pans
#10340		#10360		7" / 08 Pans

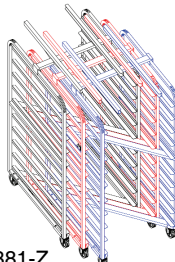

Item #10381-Z

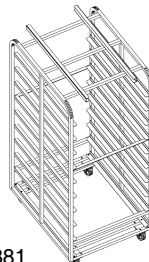

Item #10381

**Double Side Load f/ Double Rack Oven 29"Wx36"Dx70.75"H*

#10387		#10407		2" / 30 Pans
#10386		#10406		2.5" / 24 Pans
#10385		#10405		3" / 20 Pans
#10384		#10404		3.5" / 17 Pans
#10383		#10403		4" / 15 Pans
#10382		#10402		5" / 12 Pans
#10381		#10401		6" / 10 Pans
#10380		#10400		7" / 08 Pans

*Add (-Z) to the end of the Item# for Nesting.

The photos are from actual production pieces and represent typical configurations. Actual final product may differ from photos shown. The specifications may change without prior notice.



OVEN RACKS STANDARD & NESTING



"A" STYLE HANGING DEVICE 71.875" HIGH
***Single End Load 20.5"W x 26"D - 18" x 26" Pan Size**

Aluminum	Stainless Steel	Item #	Spacing/Capacity
#3009-26	#2509-26		2.75" / 21 Pans
#3008-26	#2508-26		3" / 20 Pans
#3007-26	#2507-26		3.375" / 18 Pans
#3006-26	#2506-26		4" / 15 Pans
#3005-26	#2505-26		4.75" / 13 Pans
#3004-26	#2504-26		5" / 12 Pans
#3003-26	#2503-26		6" / 10 Pans
#3002-26	#2502-26		6.75" / 09 Pans
#3001-26	#2501-26		7.5" / 08 Pans
#3000-26	#2500-26		8.75" / 07 Pans

***Single Side Load 28.5"W x 18"D - 18" x 26" Pan Size**

#2529	#2519		2.75" / 21 Pans
#2528	#2518		3" / 20 Pans
#2527	#2517		3.375" / 18 Pans
#2526	#2516		4" / 15 Pans
#2525	#2515		4.75" / 13 Pans
#2524	#2514		5" / 12 Pans
#2523	#2513		6" / 10 Pans
#2522	#2512		6.75" / 09 Pans
#2521	#2511		7.5" / 08 Pans
#2520	#2510		8.75" / 07 Pans

***Double End Load 40"W x 23"D - 18" x 26" Pan Size**

#2569	#2549		2.75" / 42 Pans
#2568	#2548		3" / 40 Pans
#2567	#2547		3.375" / 36 Pans
#2566	#2546		4" / 30 Pans
#2565	#2545		4.75" / 26 Pans
#2564	#2544		5" / 24 Pans
#2563	#2543		6" / 20 Pans
#2562	#2542		6.75" / 18 Pans
#2561	#2541		7.5" / 16 Pans
#2560	#2540		8.75" / 14 Pans

***Double Side Load 29"W(AL)/28.5"W(SS) x 36"D - 18x26**

#2559-36	#2539-36		2.75" / 42 Pans
#2558-36	#2538-36		3" / 40 Pans
#2557-36	#2537-36		3.375" / 36 Pans
#2556-36	#2536-36		4" / 30 Pans
#2555-36	#2535-36		4.75" / 26 Pans
#2554-36	#2534-36		5" / 24 Pans
#2553-36	#2533-36		6" / 20 Pans
#2552-36	#2532-36		6.75" / 18 Pans
#2551-36	#2531-36		7.5" / 16 Pans
#2550-36	#2530-36		8.75" / 14 Pans

***Single End Load 22.5"W x 26"D - 20" x 30" Pan Size**

#2769	#2759		2.75" / 21 Pans
#2768	#2758		3" / 20 Pans
#2767	#2757		3.375" / 18 Pans
#2766	#2756		4" / 15 Pans
#2765	#2755		4.75" / 13 Pans
#2764	#2754		5" / 12 Pans
#2763	#2753		6" / 10 Pans
#2762	#2752		6.75" / 09 Pans
#2761	#2751		7.5" / 08 Pans
#2760	#2750		8.75" / 07 Pans

***Double Side Load 33"W(AL)/32.5"W(SS) x 38"D - 20x30**

#2789	#2779		2.75" / 42 Pans
#2788	#2778		3" / 40 Pans
#2787	#2777		3.375" / 36 Pans
#2786	#2776		4" / 30 Pans
#2785	#2775		4.75" / 26 Pans
#2784	#2774		5" / 24 Pans
#2783	#2773		6" / 20 Pans
#2782	#2772		6.75" / 18 Pans
#2781	#2771		7.5" / 16 Pans
#2780	#2770		8.75" / 14 Pans

*Add suffix -Z for Nesting, -H for Hobart® to end of Item Number.

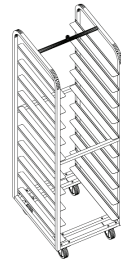

Item #3003-26



Item #3003-26-Z

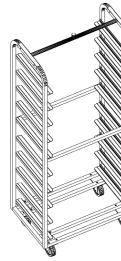

Item #2523

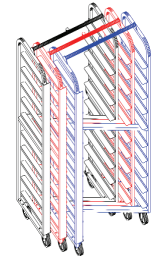

Item #2523-Z

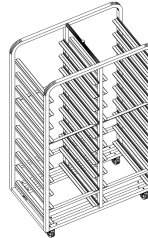

Item #2563

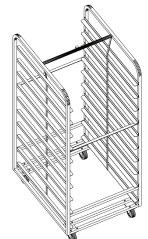

Item #2553-36

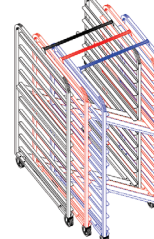

Item #2553-36-Z

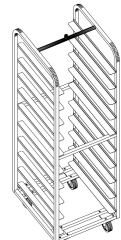

Item #2763

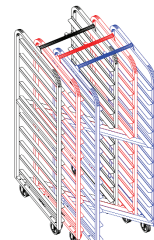

Item #2763-Z

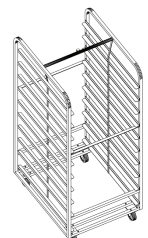

Item #2783

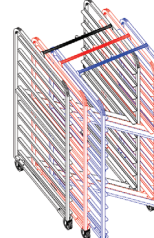

Item #2783-Z

Revent & Hobart Style Oven Standard & Nesting Racks



The photos are from actual production pieces and represent typical configurations. Actual final product may differ from photos shown. The specifications may change without prior notice.

OVEN STANDARD & NESTING RACKS



"B" STYLE HANGING DEVICE 72" HIGH

*Single End Load 20.5"W x 26"D - 18" x 26" Pan Size

Aluminum Item #	Stainless Steel Item #	Spacing/Capacity
#2599-26	#2579-26	2.75" / 21 Pans
#2598-26	#2578-26	3" / 20 Pans
#2597-26	#2577-26	3.375" / 18 Pans
#2596-26	#2576-26	4" / 15 Pans
#2595-26	#2575-26	4.75" / 13 Pans
#2594-26	#2574-26	5" / 12 Pans
#2593-26	#2573-26	6" / 10 Pans
#2592-26	#2572-26	6.75" / 09 Pans
#2591-26	#2571-26	7.5" / 08 Pans
#2590-26	#2570-26	8.75" / 07 Pans

*Single Side Load 28.5"W x 18"D - 18" x 26" Pan Size

#2609	#2589	2.75" / 21 Pans
#2608	#2588	3" / 20 Pans
#2607	#2587	3.375" / 18 Pans
#2606	#2586	4" / 15 Pans
#2605	#2585	4.75" / 13 Pans
#2604	#2584	5" / 12 Pans
#2603	#2583	6" / 10 Pans
#2602	#2582	6.75" / 09 Pans
#2601	#2581	7.5" / 08 Pans
#2600	#2580	8.75" / 07 Pans

*Double End Load 40"W x 23"D - 18" x 26" Pan Size

#2649	#2629	2.75" / 42 Pans
#2648	#2628	3" / 40 Pans
#2647	#2627	3.375" / 36 Pans
#2646	#2626	4" / 30 Pans
#2645	#2625	4.75" / 26 Pans
#2644	#2624	5" / 24 Pans
#2643	#2623	6" / 20 Pans
#2642	#2622	6.75" / 18 Pans
#2641	#2621	7.5" / 16 Pans
#2640	#2620	8.75" / 14 Pans

*Double Side Load 29"W(AL)/28.5"W(SS) x 36"D - 18x26

#2639-36	#2619-36	2.75" / 42 Pans
#2638-36	#2618-36	3" / 40 Pans
#2637-36	#2617-36	3.375" / 36 Pans
#2636-36	#2616-36	4" / 30 Pans
#2635-36	#2615-36	4.75" / 26 Pans
#2634-36	#2614-36	5" / 24 Pans
#2633-36	#2613-36	6" / 20 Pans
#2632-36	#2612-36	6.75" / 18 Pans
#2631-36	#2611-36	7.5" / 16 Pans
#2630-36	#2610-36	8.75" / 14 Pans

*Single End Load 22.5"W x 26"D - 20" x 30" Pan Size

#2809	#2799	2.75" / 21 Pans
#2808	#2798	3" / 20 Pans
#2807	#2797	3.375" / 18 Pans
#2806	#2796	4" / 15 Pans
#2805	#2795	4.75" / 13 Pans
#2804	#2794	5" / 12 Pans
#2803	#2793	6" / 10 Pans
#2802	#2792	6.75" / 09 Pans
#2801	#2791	7.5" / 08 Pans
#2800	#2790	8.75" / 07 Pans

*Double Side Load 33"W(AL)/32.5"W(SS) x 38"D - 20x30

#2829	#2819	2.75" / 42 Pans
#2828	#2818	3" / 40 Pans
#2827	#2817	3.375" / 36 Pans
#2826	#2816	4" / 30 Pans
#2825	#2815	4.75" / 26 Pans
#2824	#2814	5" / 24 Pans
#2823	#2813	6" / 20 Pans
#2822	#2812	6.75" / 18 Pans
#2821	#2811	7.5" / 16 Pans
#2820	#2810	8.75" / 14 Pans

*Add suffix -Z for Nesting, -H for Hobart® to end of Item Number.

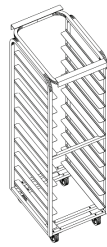

Item #2593-26

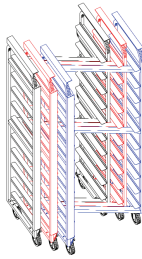

Item #2603-Z

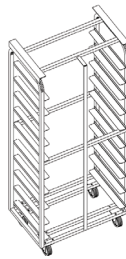

Item #2603

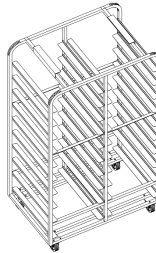

Item #2643

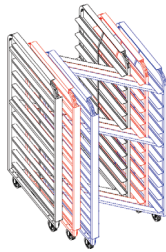

Item #2633-36-Z

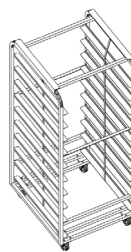

Item #2633-36

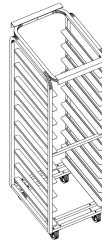

Item #2803

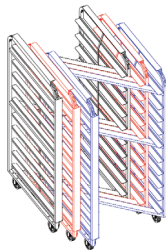

Item #2823-Z

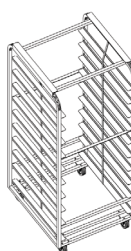

Item #2823

Revent & Hobart Style Oven Racks Standard & Nesting

The photos are from actual production pieces and represent typical configurations. Actual final product may differ from photos shown. The specifications may change without prior notice.



OVEN STANDARD & NESTING RACKS



"C" STYLE HANGING DEVICE 73.125" HIGH
***Single End Load 20.5"W x 26"D - 18" x 26" Pan Size**

Aluminum	Item #	Spacing/Capacity
#2679-26	#2659-26	2.75" / 21 Pans
#2678-26	#2658-26	3" / 20 Pans
#2677-26	#2657-26	3.375" / 18 Pans
#2676-26	#2656-26	4" / 15 Pans
#2675-26	#2655-26	4.75" / 13 Pans
#2674-26	#2654-26	5" / 12 Pans
#2673-26	#2653-26	6" / 10 Pans
#2672-26	#2652-26	6.75" / 09 Pans
#2671-26	#2651-26	7.5" / 08 Pans
#2670-26	#2650-26	8.75" / 07 Pans

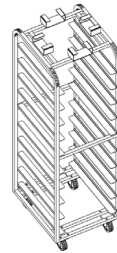

Item #2673-26

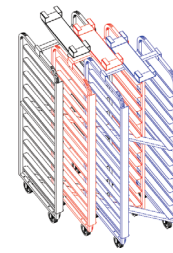

Item #2673-26-Z

***Single Side Load 28.5"W x 18"D - 18" x 26" Pan Size**

Aluminum	Item #	Spacing/Capacity
#2689	#2669	2.75" / 21 Pans
#2688	#2668	3" / 20 Pans
#2687	#2667	3.375" / 18 Pans
#2686	#2666	4" / 15 Pans
#2685	#2665	4.75" / 13 Pans
#2684	#2664	5" / 12 Pans
#2683	#2663	6" / 10 Pans
#2682	#2662	6.75" / 09 Pans
#2681	#2661	7.5" / 08 Pans
#2680	#2660	8.75" / 07 Pans

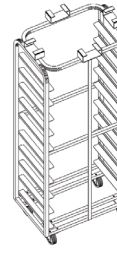

Item #2683

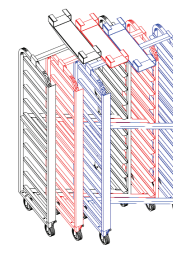

Item #2683-Z

***Double End Load 40"W x 23"D - 18" x 26" Pan Size**

Aluminum	Item #	Spacing/Capacity
#2729	#2709	2.75" / 42 Pans
#2728	#2708	3" / 40 Pans
#2727	#2707	3.375" / 36 Pans
#2726	#2706	4" / 30 Pans
#2725	#2705	4.75" / 26 Pans
#2724	#2704	5" / 24 Pans
#2723	#2703	6" / 20 Pans
#2722	#2702	6.75" / 18 Pans
#2721	#2701	7.5" / 16 Pans
#2720	#2700	8.75" / 14 Pans

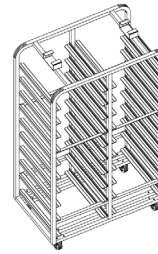

Item #2723

***Double Side Load 29"W(AL)/28.5"W(SS) x 36"D - 18x26**

Aluminum	Item #	Spacing/Capacity
#2719-36	#2699-36	2.75" / 42 Pans
#2718-36	#2698-36	3" / 40 Pans
#2717-36	#2697-36	3.375" / 36 Pans
#2716-36	#2696-36	4" / 30 Pans
#2715-36	#2695-36	4.75" / 26 Pans
#2714-36	#2694-36	5" / 24 Pans
#2713-36	#2693-36	6" / 20 Pans
#2712-36	#2692-36	6.75" / 18 Pans
#2711-36	#2691-36	7.5" / 16 Pans
#2710-36	#2690-36	8.75" / 14 Pans

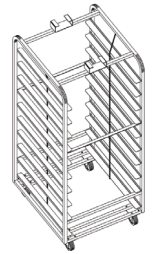

Item #2713-36

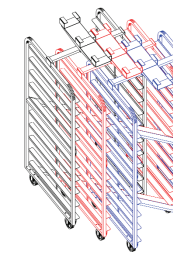

Item #2713-36-Z

***Single End Load 22.5"W x 26"D - 20" x 30" Pan Size**

Aluminum	Item #	Spacing/Capacity
#2849	#2839	2.75" / 21 Pans
#2848	#2838	3" / 20 Pans
#2847	#2837	3.375" / 18 Pans
#2846	#2836	4" / 15 Pans
#2845	#2835	4.75" / 13 Pans
#2844	#2834	5" / 12 Pans
#2843	#2833	6" / 10 Pans
#2842	#2832	6.75" / 09 Pans
#2841	#2831	7.5" / 08 Pans
#2840	#2830	8.75" / 07 Pans

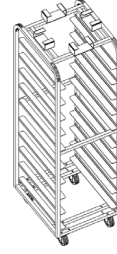

Item #2843

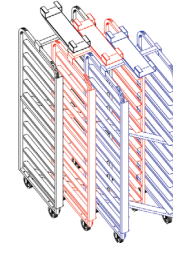

Item #2843-Z

***Double Side Load 33"W(AL)/32.5"W(SS) x 38"D - 20x30**

Aluminum	Item #	Spacing/Capacity
#2869	#2859	2.75" / 42 Pans
#2868	#2858	3" / 40 Pans
#2867	#2857	3.375" / 36 Pans
#2866	#2856	4" / 30 Pans
#2865	#2855	4.75" / 26 Pans
#2864	#2854	5" / 24 Pans
#2863	#2853	6" / 20 Pans
#2862	#2852	6.75" / 18 Pans
#2861	#2851	7.5" / 16 Pans
#2860	#2850	8.75" / 14 Pans

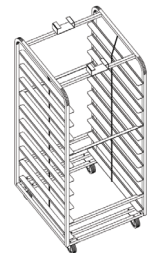

Item #2863

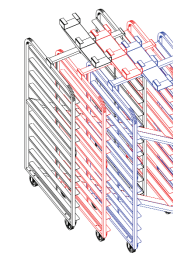

Item #2863-Z

*Add suffix -Z for Nesting, -H for Hobart® to end of Item Number.



The photos are from actual production pieces and represent typical configurations. Actual final product may differ from photos shown. The specifications may change without prior notice.

OVEN STANDARD & NESTING RACKS

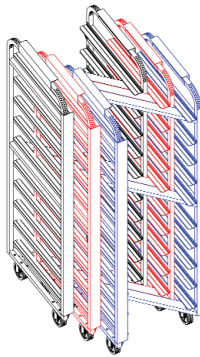

Item #2743-Z

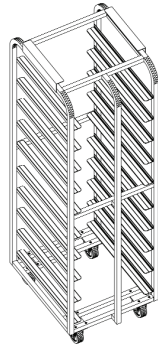

Item #2743

Caster Upgrade Options:

Add (-HIM) suffix to Item # for 5" HD Plate Caster



#6283-RULON1



#2310-GR

Replacement Plate Casters (Set of 4):

Item #2310-GR Plate Caster 4" wheel
Item #6283-RULON-1 HD Plate Caster 4" wheel

"D" STYLE HANGING DEVICE 72.25"H

*Single End Load 20.5"Wx24"D - 18" x 26" Pan Size

Aluminum

Stainless Steel

Item#	Item#	Spacing/Capacity
#2749	#2739	2.75" / 21 Pans
#2748	#2738	3" / 20 Pans
#2747	#2737	3.375" / 18 Pans
#2746	#2736	4" / 15 Pans
#2745	#2735	4.75" / 13 Pans
#2744	#2734	5" / 12 Pans
#2743	#2733	6" / 10 Pans
#2742	#2732	6.75" / 09 Pans
#2741	#2731	7.5" / 08 Pans
#2740	#2730	8.75" / 07 Pans

*Add suffix (-Z) for Nesting, (-H) for Hobart® to end of Item Number.

Available to fit most Foreign & Domestic Rack Ovens

Ideal for Retail, Wholesale, or Large Production Operations

SPECIFICATIONS:

- All Welded Construction
- Available With Heavy Duty Casters
- Custom Sizes & Designs Available
- Racks Shipped Fully Assembled Ready to Use

*Additional Options and Information: See Page 40, 44 & 45

BAKERS AID OVEN RACKS

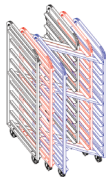

Item #23024A-BL-Z



Item #23024A-BL

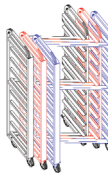

Item #23034A-BL-Z

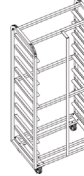

Item #23034A-BL

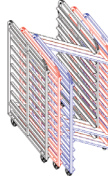

Item #23044A-BL-Z



Item #23044A-BL

Caster Upgrade Options:

Add (-HIM) suffix to Item # for 5" HD Plate Caster



#6283-RULON1



#2310-GR

Replacement Plate Casters (Set of 4):

Item #2310-GR Plate Caster 4" wheel
Item #6283-RULON-1 HD Plate Caster 4" wheel

*Single End Load for Single Oven 20.5"Wx26"Dx69"H

Aluminum

Stainless Steel

#23020A-NL*	#23050S-NL*	2" / 30 Pans
#23021A-NL*	#23051S-NL*	3" / 20 Pans
#23022A-NL*	#23052S-NL*	4" / 15 Pans
#23023A-NL*	#23053S-NL*	5" / 12 Pans
#23024A-NL*	#23054S-NL*	6" / 10 Pans

*Single Side Load for Double Oven 28.5"Wx18"Dx69"H

#23030A-NL*	#23060S-NL*	2" / 30 Pans
#23031A-NL*	#23061S-NL*	3" / 20 Pans
#23032A-NL*	#23062S-NL*	4" / 15 Pans
#23033A-NL*	#23063S-NL*	5" / 12 Pans
#23034A-NL*	#23064S-NL*	6" / 10 Pans

*Double Side Load for Double Oven 29"Wx36"Dx69"H

#23040A-NL*	#23070S-NL*	2" / 30 Pans
#23041A-NL*	#23071S-NL*	3" / 20 Pans
#23042A-NL*	#23072S-NL*	4" / 15 Pans
#23043A-NL*	#23073S-NL*	5" / 12 Pans
#23044A-NL*	#23074S-NL*	6" / 10 Pans

*Add suffix (-Z) for Nesting to end of Item Number.

Coupler Options: (-NL) No Lift (-BL) Bottom Locator
(-PG) Pin Guide (-TL) Top Lift

Available to fit most Foreign & Domestic Rack Ovens

Ideal for Retail, Wholesale, or Large Production Operations

SPECIFICATIONS:

- All Welded Construction
- Will accommodate 18"x26" trays
- Available With Heavy Duty Casters
- Custom Sizes & Designs Available
- Racks Shipped Fully Assembled Ready to Use

*Additional Options and Information: See Page 40, 44 & 45

The photos are from actual production pieces and represent typical configurations. Actual final product may differ from photos shown. The specifications may change without prior notice.



OVEN STANDARD & NESTING RACKS



Oven Racks with Bottom Locating Device *Single End Load 20.5"W x 26"D x 70.875"H

Aluminum	Stainless Steel	Spacing/Capacity
Item# #22969	Item# #23089	2.5" / 24 Pans
#22968	#23088	3" / 20 Pans
#22967	#23087	3.313" / 18 Pans
#22966	#23086	3.5" / 17 Pans
#22965	#23085	3.75" / 16 Pans
#22964	#23084	4" / 15 Pans
#22963	#23083	4.625" / 13 Pans
#22962	#23082	5" / 12 Pans
#22961	#23081	6" / 10 Pans
#22960	#23080	6.625" / 09 Pans

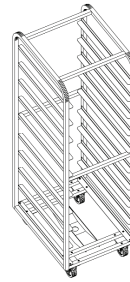

Item #22961

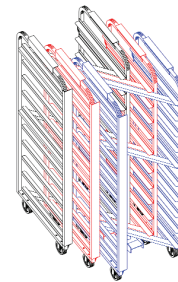

Item #22961-Z

*Single Side Load 28.5"W x 18"D x 70.875"H

#22969-SL	#23089-SL	2.5" / 24 Pans
#22968-SL	#23088-SL	3" / 20 Pans
#22967-SL	#23087-SL	3.313" / 18 Pans
#22966-SL	#23086-SL	3.5" / 17 Pans
#22965-SL	#23085-SL	3.75" / 16 Pans
#22964-SL	#23084-SL	4" / 15 Pans
#22963-SL	#23083-SL	4.625" / 13 Pans
#22962-SL	#23082-SL	5" / 12 Pans
#22961-SL	#23081-SL	6" / 10 Pans
#22960-SL	#23080-SL	6.625" / 09 Pans

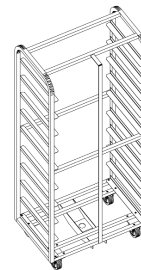

Item #22961-SL

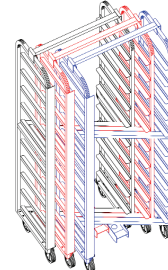

Item #22961-SL-Z

*Double Side Load 28.5"W x 36.5"D x 70.875"H

#22959	#22449	2.5" / 48 Pans
#22958	#22448	3" / 40 Pans
#22957	#22447	3.313" / 36 Pans
#22956	#22446	3.5" / 34 Pans
#22955	#22445	3.75" / 32 Pans
#22954	#22444	4" / 30 Pans
#22953	#22443	4.625" / 26 Pans
#22952	#22442	5" / 24 Pans
#22951	#22441	6" / 20 Pans
#22950	#22440	6.625" / 18 Pans

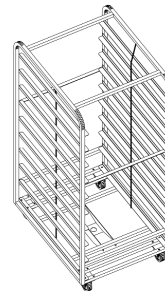

Item #22951

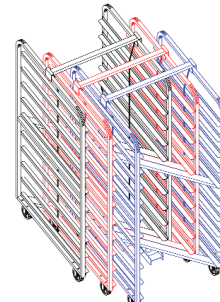

Item #22951-Z

*Add (-Z) to the end of the Item# for Nesting.

Note: Utilize page 30 to order Racks with Top Lift.

Racks Available to fit most Foreign & Domestic Ovens Ideal for Retail, Wholesale, or Large Production Operations

SPECIFICATIONS:

- All Welded Construction
 - Will accommodate 18"x26" trays
 - Available With Heavy Duty Casters
 - Custom Sizes & Designs Available
 - Racks Shipped Fully Assembled Ready to Use
- *Additional Options and Information: See Page 40, 44 & 45

Caster Upgrade Options:

Add (-HIM) suffix to Item # for 5" HD Plate Caster



#6283-RULON1



#2310-GR

Replacement Plate Casters (Set of 4):

Item #2310-GR

Plate Caster 4" wheel

Item #6283-RULON-1

HD Plate Caster 4" wheel



The photos are from actual production pieces and represent typical configurations. Actual final product may differ from photos shown. The specifications may change without prior notice.

OVEN STANDARD & NESTING RACKS

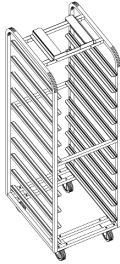

Item #23980-10-MOD1

CHANNEL STYLE f/ LFR-1 MOD. RACK OVEN 71-7/16" HIGH
Single End Load 20.5"W x 26"D - 18" x 26" Pan Size

Aluminum Item#	Stainless Steel Item#	Spacing/Capacity
#23980-20-MOD1	#23980-SS-20-MOD1	3" / 20 Pans
#23980-18-MOD1	#23980-SS-18-MOD1	3.3" / 18 Pans
#23980-15-MOD1	#23980-SS-15-MOD1	4" / 15 Pans
#23980-12-MOD1	#23980-SS-12-MOD1	5" / 12 Pans
#23980-10-MOD1	#23980-SS-10-MOD1	6" / 10 Pans

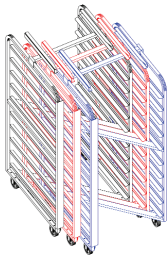

Item #20370-AL-10-SP-Z

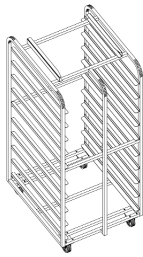

Item #20370-AL-10-SP

CHANNEL STYLE f/ LFR-2 MOD. RACK OVEN 76-5/16" HIGH
(†)*Double Side Load 29"W x 34"D - 18" x 26" Pan Size

Aluminum Item#	Stainless Steel Item#	Spacing/Capacity
#20370N-AL-30-SP	#20370N-30-SP	2" / 64 Pans
#20370N-AL-25-SP	#20370N-25-SP	2.5" / 50 Pans
#20370N-AL-20-SP	#20370N-20-SP	3" / 42 Pans
#20370N-AL-18-SP	#20370N-18-SP	3.38" / 38 Pans
#20370N-AL-15-SP	#20370N-15-SP	4" / 32 Pans
#20370N-AL-12-SP	#20370N-12-SP	5" / 26 Pans
#20370N-AL-10-SP	#20370N-10-SP	6" / 22 Pans

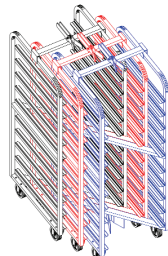

Item #23990-10-Z

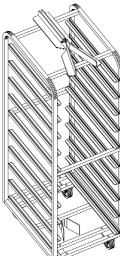

Item #23990-10

ROLLER STYLE OVEN RACKS 71-7/16" HIGH
***Single End Load 20.5"W x 26"D - 18" x 26" Pan Size**

Aluminum Item#	Stainless Steel Item#	Spacing/Capacity
#23990-20	#23990-SS-20	2.5" / 21 Pans
#23990-17	#23990-SS-17	3" / 17 Pans
#23990-15	#23990-SS-15	3.5" / 15 Pans
#23990-14	#23990-SS-14	3.75" / 14 Pans
#23990-10	#23990-SS-10	5" / 10 Pans

(†) Pan sticking out 1" on each side.

*Add (-Z) to the end of the Item# for Nesting.

Caster Upgrade Options:

Add (-HIM) suffix to Item # for 5" HD Plate Caster



#6283-RULON1



#2310-GR

Replacement Plate Casters (Set of 4):

Item #2310-GR Plate Caster 4" wheel

Item #6283-RULON-1 HD Plate Caster 4" wheel

Available to fit most Foreign & Domestic Rack Ovens
Ideal for Retail, Wholesale, or Large Production Operations

SPECIFICATIONS:

- All Welded Construction
- Available With Heavy Duty Casters
- Custom Sizes & Designs Available
- Racks Shipped Fully Assembled Ready to Use

*Additional Options: See Page 44 & 45

OVEN RACK COUPLER INFORMATION

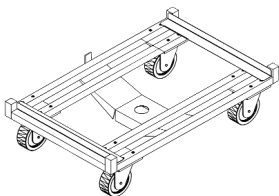

BOTTOM LOCATOR

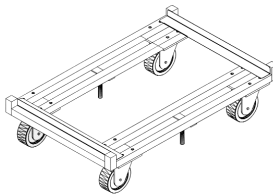

PIN GUIDE

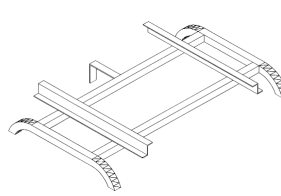

TOP LIFT

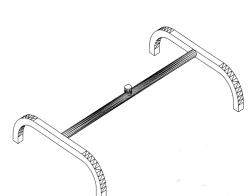

"A" LIFT

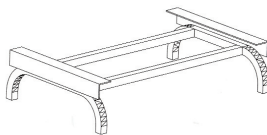

"B" LIFT (Adamatic®/Revent®)

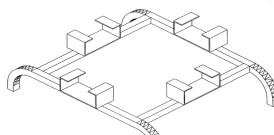

"C" LIFT for END LOAD

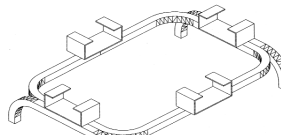

"C" LIFT for SIDE LOAD

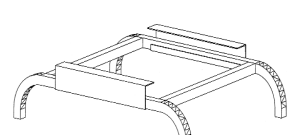

"D" LIFT (Adamatic®/Revent®)

The photos are from actual production pieces and represent typical configurations. Actual final product may differ from photos shown. The specifications may change without prior notice.



INGREDIENT HANDLING EQUIPMENT



Small Ingredient Dispensing System Table Stainless Steel Two Rows Dimensions: 103-7/8"W x 39"H to Table Top

Item#	Description
#5711-3	3-Bin Left Section w/ Wire Track Prep, Scale Mechanism, no Mezzanine Shelf
#5711-4	4-Bin Left Section w/ Wire Track Prep, Scale Mechanism, no Mezzanine Shelf
#5710-3	4-Bin Right Section w/ Wire Track Prep, Scale Mechanism, no Mezzanine Shelf
#5710-4	4-Bin Right Section w/ Wire Track Prep, Scale Mechanism, no Mezzanine Shelf
#5714	Scale Platform to Fit: One Scale 20"W x 42"L and Two Left & Right Scales 20"W x 18"L
#5712	Storage Cart Under Scale Platform w/ Shelves and casters
#10051	Bin Assembly Large - Stainless Steel Includes: Track Dolly w/ ball bearings & 4" PolyU Wheels Holding Cage and Cover w/ Hinged Lid
#5713	Bin Assembly Small - Stainless Steel Includes: Holding Shelf and Cover w/ Hinged Lid

Note: Also available with Polyethylene Bins

SPECIFICATIONS:

- Heavy duty heli-arc welded construction.
- Rolls easily on 4" casters.
- Shipped set up, ready for use.
- Call factory for quotes on your custom needs.

*Additional Options: See Page 44 & 45



ITEM #5712



ITEM #5713



ITEM # 10051

INDIVIDUAL POLYETHYLENE INGREDIENT BINS

under a preparation table or in a storeroom.

Item#	Capacity	Dimensions
#5000	2.750QF	29.25"x13.125"x28"
#5000-1	3.750QF	22.00"x22.000"x23"
#5000-2	3.500QF	29.25"x15.500"x28"
#5000-2S	3.500QF	29.12"x14.250"x26.75"
#5000-3	4.125QF	29.75"x18.000"x28"

SPECIFICATIONS:

- Integrated Sliding Lid for one handed access
- Clear Door for quick identification of ingredients
- Integrated Scoop and Storage for food code compliance
- All certified to NSF Std. #2.
- Casters allow ingredient bins to be transported
- BPA-Free



ITEM #5000

ITEM #5000-2

ITEM #5000-3

ITEM



BAKERS ACCESSORIES



Baking Tools & Equipment

Item#	Description	Size
#5092	Bowl Scraper	
#80032	Dough Cutter White	6"Wx5"H
#80033	Dough Cutter Wood	6"Wx5"H
#1481	Round Basting Brush	2" Round
#80001	Bread Slicer Dexter®	15"
#80002	Bread Slicer Dexter®	17"
#1339	Oven Gloves	17"
#8428	Pot Holders	8"x11.5"
#7836	Teflon® Pan Liners	18"x26"
#8039	Grease Gun	Maintenance Tools
#8546-LT	Application Needle	Maintenance Tools
#19275	Grease Gun Hose	Maintenance Tools
#7270	Grease Hi Temp	Maintenance Tools
#7793	Grease Low Temp	Maintenance Tools
#9689	Gray Storage Lug	16"x25"x9.5"
#9689-WH	White Storage Lug	16"x25"x9.5"
#9690	Gray Lug Cover	16"x25"x9.5"
#9690-WH	White Lug Cover	16"x25"x9.5"
#20140-3WH	Tub 3 Bushel White	19"Wx30"Lx12"H
#20140-6WH	Tub 6 Bushel White	22"Wx33"Lx21"H
#20140-6BL	Tub 6 Bushel Blue	22"Wx33"Lx21"H
#20140-6GY	Tub 6 Bushel Gray	22"Wx33"Lx21"H
#20140-6RD	Tub 6 Bushel Red	22"Wx33"Lx21"H
#20140-8WH	Tub 8 Bushel White	22"Wx41"Lx21"H
#20140-8BL	Tub 8 Bushel Blue	22"Wx41"Lx21"H
#20140-8GY	Tub 8 Bushel Gray	22"Wx41"Lx21"H
#20140-8RD	Tub 8 Bushel Red	22"Wx41"Lx21"H

Bakers Accessories

RACK COVERS



Heavy Duty Vinyl Construction Designed to Fit Standard Bakery Racks Call for Custom Sizes

Item#	Description	Dimensions
#1411	Clear Vinyl w/Zipper	23"W x 28"D x 64"H
#5258	Clear Vinyl w/Zipper	23"W x 28"D x 60"H
#5054	Proofing w/Velcro	23"W x 28"D x 64"H
#5054E	Proofing w/Zipper	23"W x 28"D x 64"H
#5089	Proofing w/Velcro	23"W x 28"D x 60"H
#1410	Freezer w/Window & Zipper	23"W x 28"D x 64"H
#1410-1	Freezer w/Window & Zipper	23"W x 28"D x 60"H

The photos are from actual production pieces and represent typical configurations. Actual final product may differ from photos shown. The specifications may change without prior notice.



BAGEL MAKERS ACCESSORIES



Bagel Baskets - Chrome Plated

Item#	Description/Size
#6757	Basket 7"x20"x6"
#6755	Basket 14"x20"x6"
#6758	Basket 21"x20"x6"
#6756	Basket 18"x24"x8"
#8495	Basket Divider 6"D x 20"L

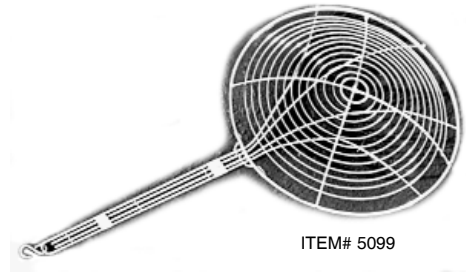
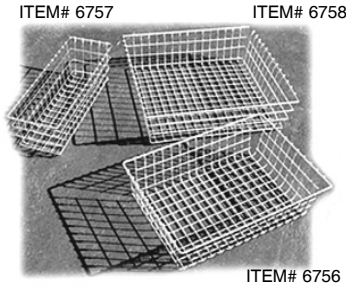

Bagel Scoop

#5099	Bagel Scoop 14"Rx32"Lx4.5"D
-------	-----------------------------

Oven Peels

Item#	Description
#6329	Aluminum 24"x24" w /30"Hndl
#6335	Plywood 24"x24" w /30"Hndl
#6335-BRN	Plywood 24"x29" w /30"Hndl
#1365-HP	Wood Hand Peel 18"x36"
#10903	Wood Hand Peel 20"x36"
#1365	Wood w/out Handle 22"x36"
#9677	Wood w/out Handle 24"x36"
#1366	Wood Handle f/Peel - 6' Long
#8467	Wood Handle f/Peel - 8' Long
#8617	Wood Handle f/Peel - 9' Long

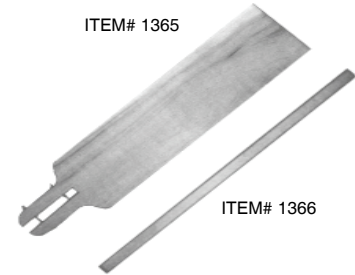
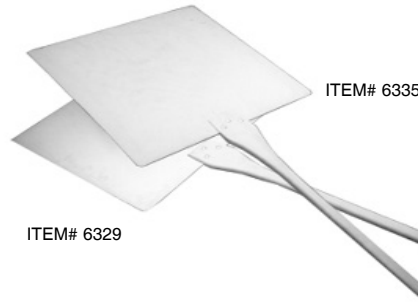

Proofing Boards

Item#	Description
#5093	Wood 18"x26" 5Ply
#6767	Plastic 18X26"
#6767-2000	Plastic 18"x26" .375" Thick
#7674	Fiberglass 18"x26"

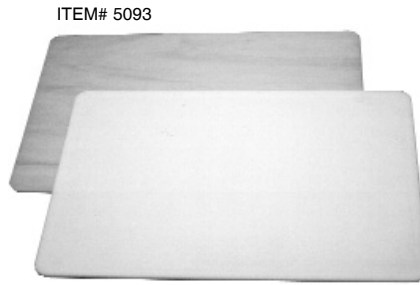

Oven Brush Wood

Item#	Description
#5221	Brush w /Hook 51"L
#5221-S	Brush w /Hook & Scraper 51"L
#7217	Brush w/out Hook 51"L
#5024	Brass Wire Head w /Scraper
#6874	Handle for Item #5024 6' Long
#6777	Hook Replacement



Kettle Stirrers

Item#	Description
#6771	Stainless Steel Stirrer - 34" Long
#6330	Wood Stirrer - 30" Long

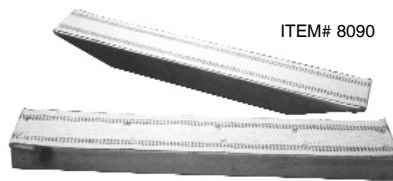

Bagel Baking Board Liners

Item#	Description
#6763	25" Wood w /Burlap
#7364	25" Wood w /Cotton
#7411	25" Wood w /Teflon®
#8074	25" Aluminum w /Cotton Clipless
#8090	25" Aluminum w /Burlap Clipless
#7412	25" Aluminum w /Teflon® Clipless
#5135-Roll	72Yds Burlap sold by the Roll
#7737-Roll	50' Cotton sold by the Roll
#7706-Roll	18 Yds Teflon sold by the Roll



Butcher's Gloves

Item#	Description
#7780	Butcher's Glove w /Liner



Bagel Makers Accessories



The photos are from actual production pieces and represent typical configurations. Actual final product may differ from photos shown. The specifications may change without prior notice.

RACK OPTIONS & UPGRADES



ITEM #1541-18



ITEM #9358 ITEM #1331-18
 ITEM #9269 ITEM #3383
 ITEM #10618 ITEM #4118
 ITEM #1541-18 ITEM #1310



ITEM #1541-18



ITEM #7024 ITEM #2326
 ITEM #6974 ITEM #2407
 ITEM #2364 ITEM #2324
 ITEM #6733 ITEM #4354
 ITEM #4333



ITEM #5641 ITEM #21958-18
 ITEM #19170 ITEM #19171
 ITEM #19172 ITEM #19173
 ITEM #19176 ITEM #19176
 ITEM #19174 ITEM #19175
 ITEM #19178 ITEM #19179
 ITEM #19180 ITEM #19181
 ITEM #19182 ITEM #19183

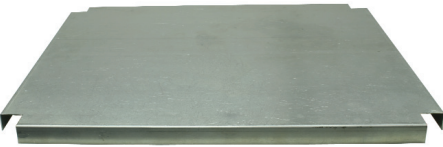

ITEM #5514-FLR ITEM #5523-FLR
 ITEM #5522-FLR ITEM #25014-FLR
 ITEM # ITEM #25013-FLR
 ITEM # ITEM #25012-FLR
 ITEM # ITEM #25011-FLR
 ITEM #25020-FLR ITEM #25147-FLR
 ITEM #25023-FLR ITEM #25235-FLR
 ITEM #25017-FLR ITEM #25197-FLR



ITEM #5921
 ITEM #5922

ITEM #19184
 ITEM #19185
 ITEM #19184-SS
 ITEM #19185-SS

Replacement Parts for

Aluminum Racks

Stainless Steel Racks

Item #	Item #	Description	Dimensions
#9358	#1541-18	Angle Slide	1.00"x1.50"x17.5"
#9269	#1331-18	Angle Slide	1.00"x1.50"x25.5"
#10618	#3383	Angle Slide	1.00"x1.50"x31.5"
#5366	#4118	Angle Slide	1.00"x1.50"x35.5"
20131	#1310	Angle Slide	1.00"x1.50"x36"
#7024	#2326	Angle Slide	0.75"x2.00"x17.5"
#6974	#2407	Angle Slide	0.75"x2.00"x25.5"
#2364	#2324	Angle Slide	0.75"x2.00"x31.5"
#6733	#4354	Angle Slide	0.75"x2.00"x35.5"
#4333	2324-36	Angle Slide	0.75"x2.00"x36"
#5641	#21958-18	Top Rack Cover	20.50"x26"
#19170	#19171	Top Rack Cover	18.00"x28.5"
#19172	#19173	Top Rack Cover	28.50"x32"
#19176	#19177	Top Rack Cover	28.50"x36"
#19174	#19175	Top Rack Cover	28.50"x36.5"
#19178	#19179	Top Rack Cover	29.00"x32"
#19180	#19181	Top Rack Cover	29.00"x36"
#19182	#19183	Top Rack Cover	29.00"x36.5"
#5514-FLR	#5523-FLR	Bottom Rack Cover	20.50"x26"
#5522-FLR	#25014-FLR	Bottom Rack Cover	28.50"x18"
	#25013-FLR	Bottom Rack Cover	28.50"x32"
	#25012-FLR	Bottom Rack Cover	28.50"x36"
	#25011-FLR	Bottom Rack Cover	28.50"x36.5"
#25020-FLR	#25147-FLR	Bottom Rack Cover	29.00"x32"
#25023-FLR	#25235-FLR	Bottom Rack Cover	29.00"x36"
#25017-FLR	#25197-FLR	Bottom Rack Cover	29.00"x36.5"
#7973-(LR)	#7973-(LR)	Pan Stop Hinged Sgl EL Kit	1"x70"(65"Net)
#7973-(LR)	#7973-(LR)	Pan Stop Hinged Sgl SL Kit	1"x70"(65"Net)
#19184	#19184-SS	"X" Brace End Load Sgl	1"x20.25"x70"(65"Net)
#19185	#19185-SS	"X" Brace Side Load Sgl	1"x28.25"x70"(65"Net)
#19186-AL	#19186	Pan Stop End Load Sgl	1"x65"(60"Net)
#19186-AL	#19186	Pan Stop Side Load Sgl	1"x65"(60"Net)
#10376	#10376	Ballast Side Load Sgl	1"x65"(60"Net)
#22188		Corner Bumper	
20279-INT		Corner Bumper for Full Perimeter Setup	
#22189		Perimeter Bumper	
#20279-END		Bumper End Cup	
#19190		Packing List Packet	
#10172		Side Handles	
#22191		Prison Package	
#19187		Excess Moisture Ventilation	



ITEM #22188

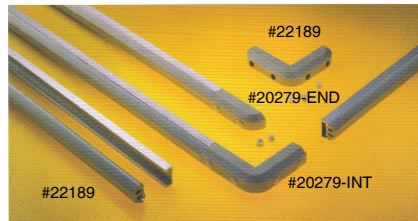

#22189

#20279-END

#22189

#20279-INT



ITEM #1541-18



ITEM #19187



ITEM #19190

The photos are from actual production pieces and represent typical configurations. Actual final product may differ from photos shown. The specifications may change without prior notice.



REPLACEMENT CASTERS & WHEELS

Replacement Casters & Wheels



FLOOR SURFACES OPERATING CONDITIONS

This chart is intended to provide the user with a general comparison of wheel types on a variety of floor surfaces and under a range of operating conditions. For specific applications or unusual conditions, please consult factory.

WHEEL APPLICATION GUIDE

Wheel Type	Capacity (lbs / w wheel)	Temperature Range °F	Durometer Ratings	Brick	Concrete	Limestone	Asphalt	Terrazzo	Wood	Smooth Steel	Ribbed Steel	Tile	Water	Steam	Mild Chemicals	Oil/Grease	Metal Chips	High Heat (475°F)	Extreme Cold (-35°F)	Animal Fats	Noise reduction	
Donut Thread	275 - 500	-20 to +180	65(±5)D	•	•	•	•	•	•	•	•	•	•	•	•	•	•	•	•	•	•	•
Mold on Polyurethane	275 - 300	-30 to +180	55(±5)D	•	•	•	•	•	•	•	•	•	•	•	•	•	•	•	•	•	•	•
Phenolic	300 - 1000	-45 to +250	85(±5)D	•	•	•	•	•	•	•	•	•	•	•	•	•	•	•	•	•	•	•
Phenolic Hi Temp	300 - 1000	-45 to +470	85(±5)D	•	•	•	•	•	•	•	•	•	•	•	•	•	•	•	•	•	•	•
Polyolefin	275 - 500	-20 to +180	65(±5)D	•	•	•	•	•	•	•	•	•	•	•	•	•	•	•	•	•	•	•
Semi-Steel	300 - 1000	-45 to +250	55(±5)D	•	•	•	•	•	•	•	•	•	•	•	•	•	•	•	•	•	•	•
Welded Disk Polyureth	275 - 300	-30 to +180	55(±5)D	•	•	•	•	•	•	•	•	•	•	•	•	•	•	•	•	•	•	•

Replacement Casters

Item #	Description/Size
#1266	Caster #3 Plate Polyurethane-WT / 4"
#1266-RGD	Caster Rigid #3 Plate Polyurethane Whl / 4"
#1266-2	Caster Stem Polyurethane-WT / 4"
#2208	Caster #3 Plate Polyurethane Whl / 5"
#2208-2	Caster #2 Plate Polyurethane Whl / 5"
#2208-LT	Caster #3 Plate Low Temp Polyurethane Whl / 5"
#9021	Caster Stem Hi Temp Polyurethane-WT / 4"
#9021-5	Caster Stem Polyurethane-WT / 5"
#9021-HT	Caster Stem Hi Temp Polyolefin Whl / 4"
#9021-LT	Caster Stem Low Temp Polyurethane Whl / 4"
#2155	Caster #3 Plate Semi-Steel Whl / 4"
#2310-GR	Caster #3 Plate Hi Temp Green Whl / 4"
#2310-2-GR	Caster #2 Plate Hi Temp Green Whl / 4"
#2310-GR-SS	Caster #3 Plate SS Hi Temp Green Whl / 4"
#2310-GR-HLW	Caster Hollow King Pin Hi Temp Green Whl / 4"
#6851	Caster #3 Plate Hi Temp Polyolefin Whl / 4"
#6851-SS	Caster #3 Plate SS Hi Temp Polyolefin Whl / 4"
#6851-HE	Caster #3 Plate Hi Temp HE-Polyolefin Whl / 4"
#10369	Caster #3 Plate Hi Temp Silicone Whl / 4"
#6283	Caster #4 Plate Phenolic Black Whl / 4"
#6283-RB	Caster #4 Plate Phenolic Roller Bearing Whl / 4"
#6283-RULON	Caster #4 Plate Phenolic Hi Temp Rulon Whl / 4"
#2886	Caster #4 Plate Phenolic Whl Roller Bearing / 5"
#2467	Caster #4 Plate Phenolic Roller Bearing Whl / 6"
#9433	Caster Stem Snap-In Rubber Wheel / 4"
#9434	Socket Insert to hold Stem Snap-In Caster / 4"
#10179-5	Caster #4 Plate Donut Whl Roller Bearing / 5"
#10179	Caster #4 Plate Donut Whl Roller Bearing / 6"
#9375	Caster Rubber Applicator w /Poly-U Wheel / 4"
#9375-BR	Caster Rubber Applicator w /Brake PU Wheel / 4"
#7409-TS	Caster Threaded Stem Polyolefin Wheel

Replacement Parts and Hardware

#5098	Brake for 4" Caster with Polyurethane Wheel
#5098-5	Brake for 5" Caster with Polyurethane Wheel
#1068-GR	Wheel Hi Temp Phenolic / 4"
#6847	Wheel Hi Temp Polyolefin / 4"
#9933	Wheel Polyurethane / 4"
#1698	Nut for Axle #1699
#1698-5-16-BL	Nut for Axle #1699-5-16-BL
#1699	Axle for Caster #2310 and #6851
#1699-NGF	Axle for Caster #2310-GR
#1699-5-16-BL	Axle for Caster #1266
#1700	Bushing for Caster #6851
#1526-1.5	Bolt for Caster Mounting 1-1/2" long
#1526-1.625	Bolt for Caster Mounting 1-5/8" long
#3758	Bolt for Caster Mounting 1-3/4" long
#2392	Washer Flat for Caster Mounting
#2311	Lock Washer for Caster Mounting
#4626	Nut for Caster Mounting

Note: Call factory for quotes on you stainless steel caster needs.

			
ITEM #1266 (4") ITEM #1266-RGD(4") ITEM #1266-2 (4") ITEM #2208 (5")	ITEM #9021 (4") ITEM #9021-5 (5") ITEM #9021-HT (4") ITEM #9021-LT (4")	ITEM #10179-5 (5") ITEM #10179 (6")	
			
ITEM #2310-GR ITEM #2310-2-GR ITEM #2310-GR-SS	ITEM #9375	ITEM #6283-RULON1 ITEM #6283-RB ITEM #2886 ITEM #2467	
			AXLE ITEM #1699-NGF NUT ITEM #1698
ITEM #6851 ITEM #6851-SS ITEM #6851-HE	ITEM #9375-BR	ITEM #1068-GR	
			BUSHING ITEM #1700 NUT ITEM #1698 AXLE ITEM #1699
ITEM #2310-GR-HLW	ITEM #9433	ITEM #6847	
			NUT ITEM #1698-5-16-BL AXLE ITEM #1699-5-16-BL
ITEM #10369	ITEM #9434	ITEM #9933	
			ITEM #1526-1.5 ITEM #1526-1.625 ITEM #3758
ITEM #1526-1.5 ITEM #1526-1.625 ITEM #3758	ITEM #2392	ITEM #2311	ITEM #4626

The photos are from actual production pieces and represent typical configurations. Actual final product may differ from photos shown. The specifications may change without prior notice.



INDIVIDUAL & STRAPPED BREAD PANS



Individual & Strapped Bread Pans

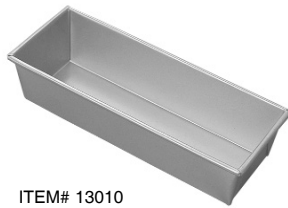

ITEM# 13010

Single Open Top Bread Pans Aluminized Steel Wire in Rim, Glazed

Item #	Top-In	Bottom-Out	Depth	Approx. Loaf Weight Lbs	Cross Reference	
					Am Pan	CM
13010	5-5/8 x 3-1/8	5 x 2-1/2	2-3/16	3/8		40415
13020*	5-5/8 x 3-1/8	5 x 2-1/2	2-1/4	3/8	5016†	
13030	7-3/8 x 3-1/8	6-3/4 x 3	2-1/4	5/8	5017†	
13032	7-1/4 x 3-5/8	6-3/4 x 3	2-1/4	1/2		45031
13040	8 x 4	7-1/4 x 3-1/4	2-1/2	3/4	5018†	41065
13050	8-1/2 x 4-1/2	7-5/8 x 3-5/8	2-3/4	1	5019†	40425
13060	9 x 4-1/2	8-1/4 x 3-3/4	2-3/4	1	5020†	40565
13070	10 x 5	9-3/8 x 4-3/8	3	1-1/2	5026†	49115
13080	12-1/4 x 4-1/2	11-1/2 x 3-3/4	2-3/4	1-1/2	5021†	40495
13090**	7-1/4 x 3-5/8	6-3/4 x 3	2-1/4	1/2	5031†	

* Seamless construction style, curled rim, no wire

** Large bottom radius, balled corners

† Legacy items



ITEM# 13210

3-Strap Open Top Bread Pans Aluminized Steel Band Over Wire, Glazed

Item #	Top-In	Bottom-Out	Depth	Overall Size	Cross Reference	
					Am Pan	CM
13210	8-1/2 x 4-1/2	7-5/8 x 3-5/8	2-3/4	9-7/32 x 17-27/32		44235
13220	9 x 4-1/2	8-1/4 x 3-3/4	2-3/4	9-23/32 x 17-3/4	5001†	45635
13230	10 x 5	9-3/8 x 4-3/8	3	10-23/32 x 18		49135†
13240	12-1/4 x 4-1/2	11-1/2 x 3-3/4	2-3/4	12-31/32 x 17-3/4	5002†	44935†

† Legacy items



ITEM# 13310

4-Strap Open Top Bread Pans Aluminized Steel Band Over Wire, Glazed

Item #	Top-In	Bottom-Out	Depth	Overall Size	Cross Reference	
					Am Pan	CM
13310	5-5/8 x 3-1/8	5 x 2-1/2	2-3/16	6-1/8 x 17-7/8		44145
13320	8 x 4	7-1/4 x 3-1/4	2-1/2	8-11/16 x 19-3/4		44065
13330	8-1/2 x 4-1/2	7-5/8 x 3-5/8	2-3/4	9-7/32 x 21-7/8	05003†	44245
13340	8-1/2 x 5-3/4	8 x 5	3	9-3/16 x 26	05035†	44585
13350	9 x 4-1/2	8-1/4 x 3-3/4	2-3/4	9-23/32 x 21-7/8	05004†	45642
13360	10 x 5	9-3/8 x 4-3/8	3	10-23/32 x 23-7/8	05005†	49145
13370	10 x 5	9-3/8 x 4-3/8	3	10-23/32 x 26		49415
13380	12 x 5	11-1/4 x 4-1/4	3-1/2	12-11/16 x 23-3/8		44765
13390	12-1/4 x 4-1/2	11-1/2 x 3-3/4	2-3/4	12-31/32 x 21-7/8	05006†	44945
13392	10 x 5	9-1/2 x 4-1/2	3-1/4	10-3/4 x 25-7/8	05036†	

† Legacy items



ITEM# 13510

5-Strap Open Top Bread Pans Aluminized Steel Band Over Wire, Glazed

Item #	Top-In	Bottom-Out	Depth	Overall Size	Cross Reference	
					Am Pan	CM
13510	7-3/8 x 3-5/8	6-3/4 x 3	2-1/4	8-1/16 x 25-3/4		44575
13520	8-1/2 x 4-1/2	7-5/8 x 3-5/8	2-3/4	9-7/32 x 26		44255
13530	9 x 4-1/2	8-1/4 x 3-3/4	2-3/4	9-23/32 x 26		45655
13540	12-1/4 x 4-1/2	11-1/2 x 3-3/4	2-3/4	12-31/32 x 26		44955



ITEM# 13610

6-Strap Open Top Bread Pans Aluminized Steel Band Over Wire, Glazed

Item #	Top-In	Bottom-Out	Depth	Overall Size	Cross Reference	
					Am Pan	CM
13610*	5-5/8 x 3-1/8	5 x 2-1/2	2-1/4	6 x 25-7/8		46925
13620	5-5/8 x 3-1/8	5 x 2-1/2	2-3/16	6-1/8 x 25-7/8		41465‡

* Individual pans have a seamless construction style, curled rim, no wire

‡ 41465 replaces 44605

The photos are from actual production pieces and represent typical configurations. Actual final product may differ from photos shown. The specifications may change without prior notice.



PULLMAN & HEARTH BREAD PANS



Single Pullman Pans Aluminized Steel Wire in Rim, Glazed

Item #	Top-In	Bottom-Out	Depth	Approx. Loaf Weight Lbs	Cross Reference	
					AmPan	CM
13710	13 x 4	12-3/4 x 3-3/4	4	1-1/2	05022†	44615
13720	Sliding Cover Fits #13710				05024†	44660
13730	16 x 4	15-3/4 x 3-3/4	4	2	05023†	44650
13740	Sliding Cover Fits #13730				05025†	44655



ITEM# 13730



ITEM# 13730
ITEM# 13740

3-Strap Pullman Pans Aluminized Steel Band Over Wire, Glazed

Individual Mold Size				Overall Size	Cross Reference	
Item #	Top-In	Bottom-Out	Depth		AmPan	CM
13810*	13 x 4	12-3/4 x 3-3/4	4	13-23/32 x 15-5/8	05009†	44635
13820	Drop Cover Non-Nesting Fits #13810			13-3/8 x 16-9/32	05010†	44645
13830**	16 x 4	15-3/4 x 3-3/4	4	16-23/32 x 15-3/4		44365
13840	Drop Cover Non-Nesting Fits #13830			17-3/8 x 16-13/32		46465

* 1-1/2 lb Approximate Loaf Weight ** 2 lb Approximate Loaf Weight
† Legacy items



ITEM# 13810

4-Strap Pullman Pans Aluminized Steel Band Over Wire, Glazed

Individual Mold Size				Overall Size	Cross Reference	
Item #	Top-In	Bottom-Out	Depth		AmPan	CM
13850*	13 x 4	12-3/4 x 3-3/4	4	13-3/4 x 21-3/8	05037†	44685
13860	Drop Cover Non-Nesting Fits #13810			14-3/4 x 22-3/8	05038†	46695

* 1-1/2 lb Approximate Loaf Weight
† Legacy items

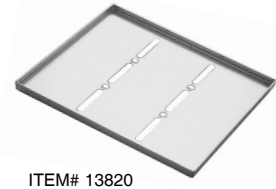

ITEM# 13820

3-Strap Hearth Bread Pan Sets Aluminized Steel Band Over Wire, Glazed Bottom and Sidewall Perforation Flat Bottom

Individual Mold Size				Overall Size	Cross Reference	
Item #	Top-In	Bottom-Out	Depth		AmPan	CM
14010	7-3/8 x 3-5/8	11 x 3-1/2	2-1/2	12-3/16 x 25-7/8	05044†	44405

† Legacy items

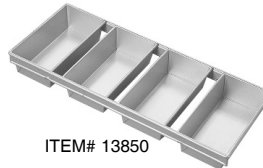

ITEM# 13850

4-Strap Hearth Bread Pan Sets Aluminized Steel Band Over Wire, Glazed Quilted Bottom and Single Row of Sidewall Perforations

Individual Mold Size				Overall Size	Cross Reference	
Item #	Top-In	Bottom-Out	Depth		AmPan	CM
14020	11-1/2 x 5-3/4	11 x 3-7/8	2-3/4	12-3/16 x 26		41695

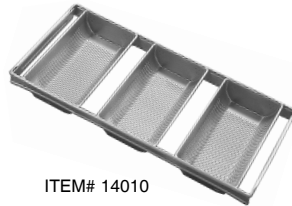

ITEM# 14010

Cinnamon/Package Roll Pan Set 3 Pans per Set Aluminized Steel Band Over Wire

Individual Mold Size				Overall Size	Cross Reference	
Item #	Top-In	Bottom-Out	Depth		AmPan	CM
14220	11-1/2 x 5-3/4	11 x 3-7/8	2-3/4	12-3/16 x 26		41145



ITEM# 14020



ITEM# 14220

Pullman & Hearth Bread Pans



The photos are from actual production pieces and represent typical configurations. Actual final product may differ from photos shown. The specifications may change without prior notice.

PANS & TRAYS



ITEM# 14110

Crimped Round Bread Set - 4 Pan per Set, 26 Ga. Aluminized Steel, Glazed 1-5/8" Band Over Wire. Approximate Loaf weight: 1lb

Item #	Length	Diameter	Overall Size	AmPan	CM
14110	10	3-3/4	10-9/16 x 18-3/8		48514

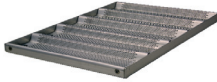

ITEM# 14320

Half Size Sub-Sandwich Roll Pans Perforated Aluminium Welded Construction 5 individual flat bottomed perforated molds each with end cups

Item #	Molds per		Mold Size		Depth	Overall Size	Cross Reference	
	Pan	Top In	Bottom-Out	AmPan			CM	
14320	5	12-1/2 x 3	12-1/2 x 2-1/4	3/4	18 x 12-15/16 x 1			49015



ITEM# 14310

Full Size Sub-Sandwich Roll Pans Perforated Aluminium Welded Construction 10 individual flat bottomed perforated molds each with end cups

Item #	Molds per		Mold Size		Depth	Overall Size	Cross Reference	
	Pan	Top In	Bottom-Out	AmPan			CM	
14310	10	12-1/2 x 3	12-1/2 x 2-1/4	3/4	18 x 25-15/16 x 1			49015



ITEM# 14590

Breadstick Pan 14 Gauge Aluminum

Item #	Groves	Groove Width	Overall Size	AmPan	CM
14590	14	9/16	17-7/8 x 25-7/8		44755



ITEM# 14610

Hamburger Bun Pans / Muffin Top Pans Seamless Construction - Aluminized Steel

Item #	Top-In	Bottom		Depth	Mold Layout	Overall Size	Cross Reference	
		Out	Out				AP / CM	AP / CM
14610*	3-3/4	3-1/16	13/32	1/2	4 x 6	17-11/16 x 25-11/16 x 1-1/8		42495
14620*	4-1/4	3-5/8	1/2	1/2	4 x 6	19-1/2 x 28-3/4 x 1-1/8		42345
14630*	4-1/8	3-7/8	1/2	1/2	3 x 5	17-11/16 x 25-11/16 x 1-1/8		42425
14640±	3-5/8	3-3/8	9/16	1/2	4 x 6	17-3/4 x 25-3/4 x 1-1/8		01032†
14650*	3-5/8	3-3/8	9/16	1/2	4 x 6	17-3/4 x 25-3/4 x 1-1/8		02520†
14660±	4-1/8	3-3/4	1/2	1/2	3 x 5	17-3/4 x 25-3/4 x 1-1/8		01002†
14670**±	4-1/8	3-7/8	1-1/8	1/2	2 x 3	12 x 17-5/8		01006†
14680±	5	4-3/4	1/2	1/2	3 x 4	17-3/4 x 25-3/4 x 1-1/8		01005†

Clustered molds, 4 buns/rolls per cluster

14700†	3-3/4	3-3/8	1/2	1/2	2 x 3	17-11/16 x 25-11/16 x 1-1/8		42445#
--------	-------	-------	-----	-----	-------	-----------------------------	--	--------

* 1/4" Diameter wire in rim

** Molds seamed

01008 Old CM item

± 1/2" Band in rim
† Legacy items



ITEM# 14700

Hot Dog Bun Pans Seamless Construction Aluminized Steel 1/4" Diameter Wire in Rim

Item #	Top-In	Bottom		Depth	Mold Layout	Overall Size	Cross Reference	
		Out	Out				AP / CM	AP / CM
14810**±	6x2-1/16	5-1/2x1-9/16	1/2	1/2	4 x 6	16-3/4 x 27-3/4 x 1		42415
14820	6x2-1/16	5-1/2x1-9/16	1/2	1/2	3 x 6	17-11/16 x 25-11/16 x 1-1/8		42435
14830	6x1-7/8	5-11/16x1-5/8	1/2	1/2	3 x 6	17-3/4 x 25-3/4 x 1-1/8		02500 OE†
14840±	6x1-7/8	5-11/16x1-5/8	1/2	1/2	4 x 6	16-3/4 x 27-3/4 x 1		02530 OE†
14850±	7-7/8x2-1/2	7-5/16x2-1/8	7/16	1/2	2 x 6	17-3/4 x 25-3/4 x 1-1/8		01055 OE†
14860	10x2-1/8	9-1/2x1-5/8	3/8	1/2	2 x 6	17-3/4 x 25-3/4 x 1-1/8		02510 MB†

Clustered molds, 4 molds per cluster

14880**±	6x2-1/16	5-1/2x1-9/16	17/32	1/2	2 x 4	19-3/4 x 29 x 1-1/8		02505 OE†
14890*±***	12x2-3/4	11-3/4x2-7/16	3/8	1/2	1 x 2	17-3/4 x 25-3/4 x 1-1/8		01052 BE†
14895±	12x2-3/4	11-3/4x2-7/16	3/8	1/2	1 x 2	17-3/4 x 25-3/4 x 1-1/8		01052 BE†

** Will not fit 18 x 26 racks

† Legacy items

*** Each cluster has 5 buns/rolls

± Will not fit 18 x 26 side load racks
± 1/2" Band in rim



ITEM# 14880

Specialty / Bun & Roll Pans

The photos are from actual production pieces and represent typical configurations. Actual final product may differ from photos shown. The specifications may change without prior notice.



PANS & TRAYS



BAKER PRO SERIES TRAYS

3-Channel Long Baguette/French Bread Trays

Overall Dimensions: 26" x 18" x 1-5/16"

Item#	Mold Dimensions	Cross Reference	
		AmPan	CM
#11450-BP-NC	5 x 25-3/4	09011†	49011
#11450-BP-AN	5 x 25-3/4	09011†	49011
#11450-BP-SG	5 x 25-3/4	09011	49011
#11450-BP-TEF	5 x 25-3/4	09011	49011

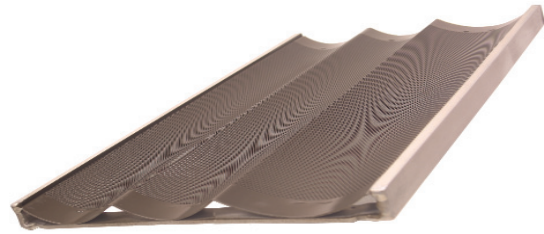

ITEM# 11450-BP-TEF

4-Channel Long Baguette/French Bread Trays

Overall Dimensions: 26" x 18" x 1-5/16"

Item#	Mold Dimensions	Cross Reference	
		AmPan	CM
#11410-BP-NC	3-7/8 x 25-3/4	09004†	49034
#11410-BP-AN	3-7/8 x 25-3/4	09004†	49034
#11410-BP-SG	3-7/8 x 25-3/4	09004†	49034
#11410-BP-TEF	3-7/8 x 25-3/4	09004†	49034

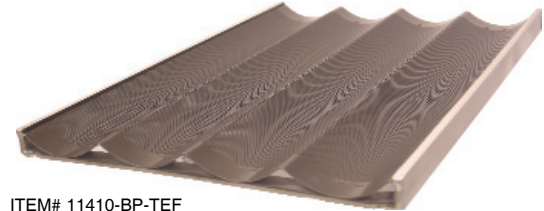

ITEM# 11410-BP-TEF

5-Channel Long Baguette/French Bread Trays

Overall Dimensions: 26" x 18" x 1-5/16"

Item#	Mold Dimensions	Cross Reference	
		AmPan	CM
#11420-BP-NC	3 x 25-3/4	09005†	49035
#11420-BP-AN	3 x 25-3/4	09005†	49035
#11420-BP-SG	3 x 25-3/4	09005†	49035
#11420-BP-TEF	3 x 25-3/4	09005†	49035

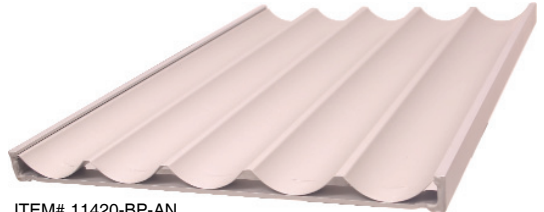

ITEM# 11420-BP-AN

5-Channel Across Baguette/French Bread Trays

Overall Dimensions: 26" x 18" x 1-5/16"

Item#	Mold Dimensions	Cross Reference	
		AmPan	CM
#11430-BP-NC	3-7/8 x 17-3/4	09009†	45505
#11430-BP-AN	3-7/8 x 17-3/4	09009†	45505
#11430-BP-SG	3-7/8 x 17-3/4	09009†	45505
#11430-BP-TEF	3-7/8 x 17-3/4	09009†	45505

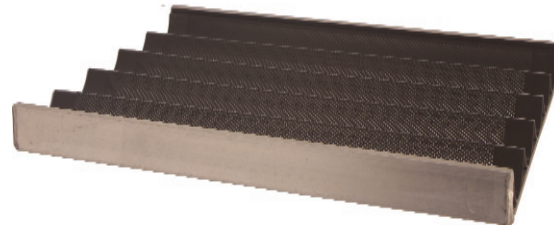

ITEM# 11430-BP-TEF

6-Channel Long Baguette/French Bread Trays

Overall Dimensions: 26" x 18" x 1-5/16"

Item#	Mold Dimensions	Cross Reference	
		AmPan	CM
#11440-BP-NC	2-13/32 x 25-3/4	09006†	49036
#11440-BP-AN	2-13/32 x 25-3/4	09006†	49036
#11440-BP-SG	2-13/32 x 25-3/4	09006†	49036
#11440-BP-TEF	2-13/32 x 25-3/4	09006†	49036

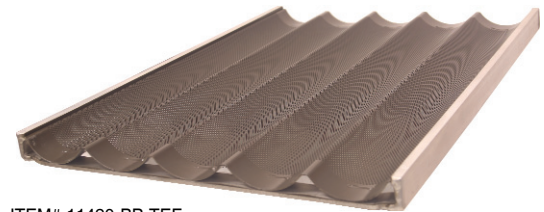

ITEM# 11420-BP-TEF

† Legacy items

NC - No Coating

SG - Silicone Glaze

AN - Anodized

TEF - Teflon® Coating

Storage Racks & Trucks for All Size Trays Available

Industrial Baguette & Flat Trays:

Ideal for Retail, Wholesale, and Large Production Operations

SPECIFICATIONS:

- All Welded Aluminum Frame
- All Flutes Welded Securely to the Frame for Added Strength
- Available With Perforated or Solid Bake Surface
- Custom Sizes & Perforation Patterns Available
- Trays Are Shipped Packaged In Cartons
- Trays can be Ordered with No-Coating, Anodized, Silicone Glaze or Non-Stick Teflon® - 5,000 Plus Bake Cycles

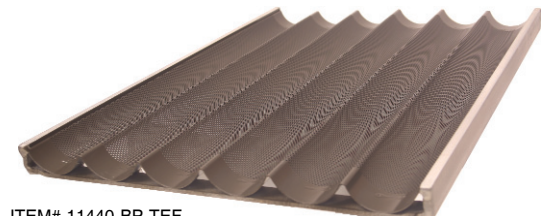

ITEM# 11440-BP-TEF

The photos are from actual production pieces and represent typical configurations. Actual final product may differ from photos shown. The specifications may change without prior notice.



PANS & TRAYS



ITEM #18400_TR_4TN_RB

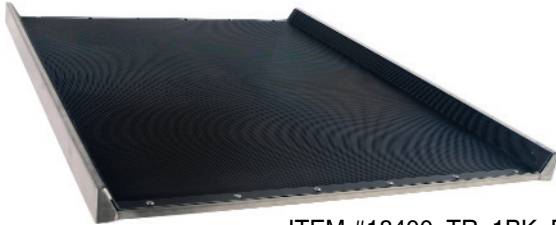

ITEM #18400_TR_1BK_FT

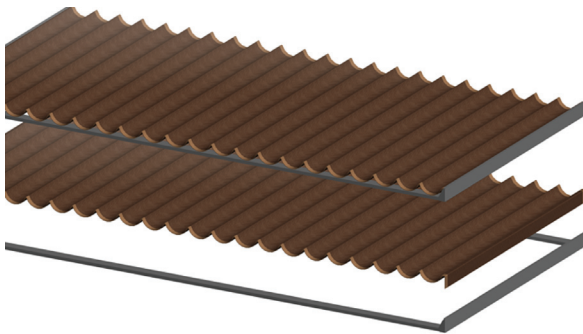

ITEM #18600_TR_3BR_RB

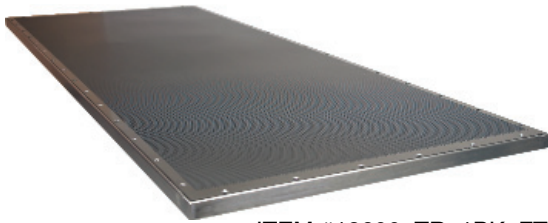

ITEM #18600_TR_1BK_FT

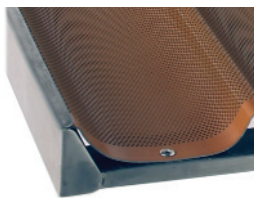

Flat Bottom

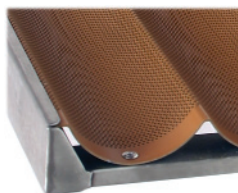

Round Bottom

Meca Trays

Overall Dimensions: 800mm x 600mm x 40mm

Item#	Color	Shape	Configuration
#18400_TR_1xx_FT			Flat Screen
#18400_TR_2xx_xx			6 - Channels
#18400_TR_3xx_xx			7 - Channels
#18400_TR_4xx_xx			8 - Channels

Meca Trays

Overall Dimensions: 800mm x 1600mm x 50mm

Item#	Color	Shape	Configuration
#18500_TR_1xx_FT			Flat Screen
#18500_TR_2xx_xx			16 - Channels
#18500_TR_3xx_xx			19 - Channels
#18500_TR_4xx_xx			21 - Channels

Meca II Trays

Overall Dimensions: 800mm x 2000mm x 50mm

Item#	Color	Shape	Configuration
#18600_TR_1xx_FT			Flat Screen
#18600_TR_2xx_xx			21 - Channels
#18600_TR_3xx_xx			22 - Channels
#18600_TR_4xx_xx			23 - Channels
#18600_TR_5xx_xx			27 - Channels

Color options:

BR - Brown
BK - Black
BL - Blue
TN - Tan

Shape options:

FB - Flat Bottom
RB - Round Bottom
FB - Flat Bottom

Replacement Screens of All Sizes Available
Storage Racks for All Size Trays Available

Industrial Baguette & Flat Trays:

Ideal for Mecatherm and other Industrial Bread Lines

SPECIFICATIONS:

- All Welded Type 304 Series Stainless Steel Frame
- Stainless Steel Rivets In All Flutes for Added Strength
- Consistent Hole Pattern for EZ Screen Replacement
- Available With Perforated or Solid Bake Surface
- Custom Sizes & Perforation Patterns Available
- Non-Stick Teflon® Coatings - 5,000 Plus Bake Cycles
- Trays Are Shipped Packaged In Cartons

Mecatherm Style Trays

The photos are from actual production pieces and represent typical configurations. Actual final product may differ from photos shown. The specifications may change without prior notice.



MUFFIN PANS



Mini Muffin and Cupcake Pans Cookie Sheet Style Aluminized Steel 5/16" Wire in Rim, Glazed

Mini Muffin Pans

Item #	Bottom			Vol.*	Mold Layout	Centers		Overall Size	Cross Reference	
	Top-In	Out	Depth			L	W		Am Pan	CM
15110	2-1/16	1-5/8	11/16	1.1	4 x 6	2-1/2	2-1/2	11-1/8 x 15-3/4		50024†
15120	1-7/8	1-1/4	7/8	1.1	5 x 6	2-3/4	2-1/4	12-7/8 x 17-7/8	03014†	45195
15130	1-7/8	1-1/4	7/8	1.1	6 x 8	2-3/4	2-1/4	17-7/8 x 25-7/8	03006†	45295
15140**	2-1/16	1-5/8	1-1/8	2.1	4 x 6	2-3/4	2-3/4	12-7/8 x 17-7/8	03001†	45245
15150	2-1/16	1-5/8	1-1/8	2.1	6 x 8	2-3/4	2-3/4	17-7/8 x 25-7/8	03029†	45255

Cupcake / Muffin Pans Aluminized Steel

15210***	2-3/4	2-1/16	1-3/8	3.8	3 x 4	3-5/16	3-5/16	10-5/8 x 13-7/8	03022†	45125
15220	2-3/4	2-1/16	1-3/8	3.8	3 x 4	4	4	12-7/8 x 17-7/8		45225
15230†	2-3/4	2-1/16	1-3/8	3.8	4 x 6	3-5/16	3-5/16	14-1/16 x 20-11/16	03007†	45525
15240	2-3/4	2-1/16	1-3/8	3.8	5 x 7	3-5/16	3-5/16	17-7/8 x 25-7/8	03010†	45575
15250	2-3/4	2-1/16	1-3/8	3.8	4 x 6	4	4	17-7/8 x 25-7/8	03015†	45605
15260	2-3/4	2-1/16	1-3/8	3.8	5 x 7	3-9/32	3-5/16	17-7/8 x 25-7/8	03033†	

Aluminum Muffin Pans

15410	2-3/4	2-1/16	1-3/8	3.8	3 x 4	3-5/16	3-5/16	10-3/4 x 14-1/8		46125
15420	2-3/4	2-1/16	1-3/8	3.8	4 x 6	3-5/16	3-5/16	20-3/4 x 14-1/8		46525
15430‡	4-1/4	3-11/16	1-3/8	10.5	2 x 3	4-7/8	4-27/32	10-3/4 x 15-1/2		46215

* Volume (Vol.) indicates liquid volume of mold filled to brim - use 60-70% for batter weight

** 26 Gauge

‡ Cinnamon Roll

*** No wire in rim 26 Gauge

† Legacy items



ITEM# 15230



ITEM# 15312

Oversized Muffin Pans Cookie Sheet Style 22 Gauge Aluminized Steel 5/16" Wire in Rim, Glazed

Large Muffin

Item #	Bottom			Vol.*	Mold Layout	Centers		Overall Size	Cross Reference	
	Top-In	Out	Depth			L	W		Am Pan	CM
15310	3-1/4	2-1/2	1-1/4	5.0	3 x 4	3-5/8	3-5/8	12-7/8 x 17-7/8	03009†	43645
15312	3-1/4	2-1/2	1-1/4	5.0	4 x 6	3-5/8	3-5/8	17-7/8 x 25-7/8	03020†	45645

Texas Size Muffin

15320	3-3/16	2-15/16	1-1/4	5.6	3 x 4	3-5/8	3-5/8	12-7/8 x 17-7/8		43215
15322	3-3/16	2-15/16	1-1/4	5.6	4 x 6	3-5/8	3-5/8	17-7/8 x 25-7/8		45265

Jumbo Muffin

15330	3-1/2	3-1/32	1-1/4	6.2	3 x 4	4-1/8	4-1/8	13-1/8 x 17-7/8	03018†	43515
15332	3-1/2	3-1/32	1-1/4	6.2	4 x 5	4-1/8	4-1/8	17-7/8 x 25-7/8		44515
15334	3-3/8	3	1-1/2	7.0	3 x 4	4	3-15/16	12-7/8 x 17-7/8		43375
15336	3-3/8	3	1-1/2	7.0	4 x 6	3-7/8	4	17-7/8 x 25-7/8		45285
15338	3-3/8	2-15/16	1-17/32	7.0	4 x 6	4	4	17-7/8 x 25-7/8	03032†	45445

* Volume (Vol.) indicates liquid volume of mold filled to brim - use 60-70% for batter weight

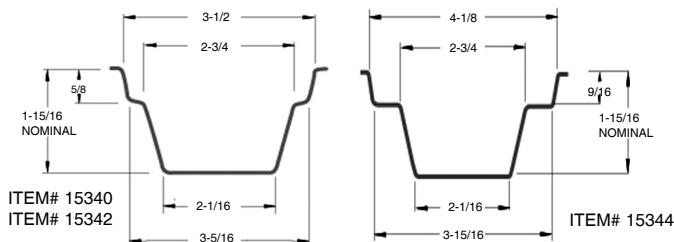

Large Muffin Pans Cookie Sheet Style 22 Gauge Aluminized Steel 5/16" Wire in Rim, Glazed

Large Crown Muffin

Item #	Bottom			Vol.*	Mold Layout	Centers		Overall Size	Cross Reference	
	Top-In	Out	Depth			L	W		Am Pan	CM
15340	3-1/2	2-1/16	1-15/16	7.3	3 x 4	4-1/8	4-1/8	13-1/8 x 17-7/8	03025†	43555
15342	3-1/2	2-1/16	1-15/16	7.3	4 x 5	4-1/8	4-1/8	17-7/8 x 25-7/8	03026†	44555
15344	4-1/8	2-1/16	1-15/16	7.5	3 x 5	4-5/8	4-5/8	17-3/4 x 25-5/8	03028†	45435

Pecan Roll

15350	3-11/16	2-1/2	1-13/16	8.2	3 x 4	4-1/4	4-1/4	13-1/2 x 17-7/8	03003†	43695
15352	3-11/16	2-1/2	1-13/16	8.2	4 x 5	4-1/4	4-1/4	17-7/8 x 25-7/8	03021†	44705

Mini Cake Muffin

15360	4-1/4	3-3/4	1-1/2	10.5	3 x 4	4-7/8	4-7/8	15-1/2 x 20-1/2	03041†	44215
15362	4-1/4	3-3/4	1-1/2	10.5	3 x 5	4-21/32	4-7/8	17-7/8 x 25-7/8	03031†	45305
15364	4-1/8	3-3/4	1-1/2	10.0	3 x 5	4-5/8	4-7/8	17-7/8 x 25-7/8		43035
15366	5-1/4	4-3/4	1-1/2	16.5	3 x 4	5-5/8	5-11/16	17-7/8 x 25-7/8		45355

* Volume (Vol.) indicates liquid volume of mold filled to brim - use 60-70% for batter weight. † Legacy items



ITEM# 15360

The photos are from actual production pieces and represent typical configurations. Actual final product may differ from photos shown. The specifications may change without prior notice.

SPECIALTY MUFFIN / BUNDT CAKE PANS

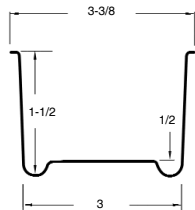

ITEM# 15510
ITEM# 15520



ITEM# 15710

Specialty Muffin Pans Cookie Sheet Style, Glazed
22 Gauge Aluminized Steel 5/16" Wire in Rim, indent size 2" x 1/2" deep
Mary Ann / Strawberry Shortcake

Item #	Btm.			Vol.*	Mold Layout	Centers		Overall Size	Cross Reference	
	Top-In	Out	Dept			L	W		AmPan	CM
15510**	3-3/8	3	1-1/2	6.0	3 x 4	4	3-15/16	12-7/8 x 17-7/8	03005†	43385
15520**	3-3/8	3	1-1/2	6.0	4 x 6	3-13/16	3-13/16	17-7/8 x 25-7/8		43395
Mini Loaf - Top In: 3-7/8 x 2-1/2 - Bottom Out: 3-1/2 x 2-1/8										
15610	3-7/8	2-1/2	1-5/16	6.4	2 x 6	3-1/8	4-1/2	9-7/8 x 19-1/2	05013†	45755
15620	3-7/8	2-1/2	1-5/16	6.4	4 x 7	3-1/8	4-1/2	18-7/8 x 25-7/8	05015†	45725
15630	3-7/8	2-1/2	1-5/16	6.4	3 x 8	3-1/8	4-1/2	17-7/8 x 25-7/8	05014†	
Square Muffin - Top In: 2-5/8 x 2-5/8 - Bottom Out: 2 x 2										
15710‡	2-5/8	2	1-9/16	4.4	3 x 4	3-1/4	3-1/8	10-3/4 x 14-1/8		
15720‡	2-5/8	2	1-9/16	4.4	4 x 6	3-1/8	3-1/4	14-1/8 x 20-3/4		46605
Square Muffin - Top In: 2-5/8 x 2-5/8 - Bottom Out: 2-1/4 x 2-1/4										
15730**†	2-3/4	2-1/4	1-1/4	4.4	3 x 4	3-1/4	3-1/4	10-7/16 x 13-3/4	03050†	

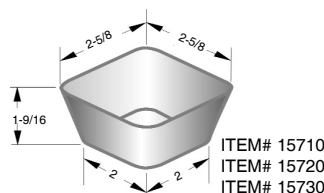

ITEM# 15710
ITEM# 15720
ITEM# 15730

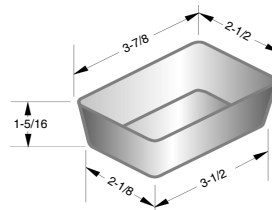

ITEM# 15610
ITEM# 15620
ITEM# 15630

* Volume (Vol.) indicates liquid volume of mold filled to brim - use 60-70% for batter w eight
** 26 Gauge Aluminized ‡ Aluminum † Legacy items

BUNDT CAKE PANS



ITEM# 31514

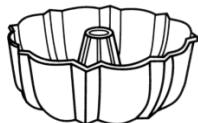

ITEM# 22433



ITEM# 31513



ITEM# 22808



ITEM# 31515

BUNDT BAKEWARE

Heavy Cast Aluminum Bakeware

ITEM #	NORDIC DESCRIPTION	DIMENSIONS
22948	51202 Original 6-Cup Bundt Pan	8.25"(l)x8.25"(w)x3"(h)
22433	50501 Original 12-Cup Bundt Pan	10.25"(l)x10.25"(w)x3.75"(h)
31510	80602 Heritage 10-Cup Bundt Pan	10"(l)x10"(w)x4"(h)
31511	52502 Pound Cake/Angel Food 16-Cup Pan	11.25"(l)x10"(w)x5"(h)
31512	58202 Holiday Star 10-Cup Bundt Pan	10.5"(l)x9.875"(w)x4"(h)
31513	53602 Bavaria 10-Cup Bundt Pan	9.25"(l)x9.25"(w)x3.75"(h)
31514	54102 Rose 10-Cup Bundt Pan	9.25"(l)x9.25"(w)x3.875"(h)
22808	50602 Original Six 1-Cup Bundt Muffin Pan	14"(l)x9"(w)x2"(h)
31515	53802 Bundt Quartet Four 2.25-Cup Size Pan	12.375"(l)x12.375"(w)x2.375"(h)
31516	52802 Bundt Brownie Twelve 1/3-Cup Pan	13.5"(l)x9.5"(w)x1.25"(h)
31517	54402 Multi Mini Six 1-Cup Bundt Pan	14.25"(l)x9"(w)x2"(h)
31518	82902 Floral Bouquet Six 3-Cup Cupcake Pan	12.68"(l)x8.13"(w)x1.64"(h)
31519	55002 Mini Heart Six 1/2-Cup Baking Pan	8.75"(l)x8.75"(w)x1.5"(h)
31520	57802 Quilted Heart 8-Cup Baking Pan	11"(l)x10.875"(w)x2.25"(h)
31521	58302 Lemon Loaf 6-Cup Pan	11"(l)x5.75"(w)x3"(h)

ANGEL FOOD CAKE PANS



ITEM# 37090

ITEM# 37000

ITEM# 37003

Cake Pans Aluminum Solid Bottom

Item #	Pan Dimensions			Tube Dimensions		
	Top In	Bottom Out	Depth	Top In	Bottom Out	Depth
37000	7-1/2	7	2-3/4	1-3/4	2-5/8	2-3/4
37001	7-1/2	6-7/8	3-1/8	2-9/16	3-1/8	3-1/8
37002	8-1/2	7-1/4	4	2-1/8	3	3-7/8
37003	9-1/4	8-1/4	4	2-1/8	3	3-7/8
37003-1	9-1/2	8-1/2	4	2-3/8	3-1/8	3-7/8
37004	10	9-1/2	3-3/4	3-1/8	4	3-3/4

Tube Cake Pan Aluminum Removable Bottom

Item #	Pan Dimensions	Capacity
37090	9-1/2 x 8-1/4 x 4-1/8	3-1/2 Qts

The photos are from actual production pieces and represent typical configurations. Actual final product may differ from photos shown. The specifications may change without prior notice.

ROUND CAKE PANS



Round Cake Pans

Round Cake Pans 1.5" & 2" Deep Aluminum & Aluminized Steel

Aluminum **Aluminized Steel**

18 gauge

22 gauge

ITEM#

ITEM#

PAN DIMENSIONS

37150		5" ID x 1-1/2" (12.7cm x 3.8cm)
37151	37151-AS	6" ID x 1-1/2" (15.2cm x 3.8cm)
37152		7" ID x 1-1/2" (17.8cm x 3.8cm)
37153	37153-AS	8" ID x 1-1/2" (20.3cm x 3.8cm)
37154	37154-AS	9" ID x 1-1/2" (22.9cm x 3.8cm)
37155		10" ID x 1-1/2" (25.4cm x 3.8cm)
37156		11" ID x 1-1/2" (27.9cm x 3.8cm)
37157		12" ID x 1-1/2" (30.5cm x 3.8cm)
37158		13" ID x 1-1/2" (33.0cm x 3.8cm)
37159		14" ID x 1-1/2" (35.5cm x 3.8cm)
37160		15" ID x 1-1/2" (38.1cm x 3.8cm)
37161		16" ID x 1-1/2" (40.6cm x 3.8cm)
37162		17" ID x 1-1/2" (43.2cm x 3.8cm)



ITEM# 37150

16 gauge

22 gauge

37170

18" ID x 1-1/2" (45.7cm x 3.8cm)

37171

20" ID x 1-1/2" (50.8cm x 3.8cm)

37172

22" ID x 1-1/2" (55.9cm x 3.8cm)

37173

24" ID x 1-1/2" (61.0cm x 3.8cm)

18 gauge

22 gauge

37130

5" ID x 2" (12.7cm x 5.1cm)

37131

37131-AS

6" ID x 2" (15.2cm x 5.1cm)

37132

37132-AS

7" ID x 2" (17.8cm x 5.1cm)

37133

37133-AS

8" ID x 2" (20.3cm x 5.1cm)

37134

37134-AS

9" ID x 2" (22.9cm x 5.1cm)

37135

37135-AS

10" ID x 2" (25.4cm x 5.1cm)

37136

11" ID x 2" (27.9cm x 5.1cm)

37137

37137-AS

12" ID x 2" (30.5cm x 5.1cm)

37138

13" ID x 2" (33.0cm x 5.1cm)

37139

37139-AS

14" ID x 2" (35.5cm x 5.1cm)

37140

15" ID x 2" (38.1cm x 5.1cm)

37141

37141-AS

16" ID x 2" (40.6cm x 5.1cm)

37142

17" ID x 2" (43.2cm x 5.1cm)



ITEM# 37130

Round Cake Pans 1" Deep Aluminum & Aluminized Steel

Aluminum

Aluminized Steel

18 gauge

22 gauge

ITEM#

ITEM#

PAN DIMENSIONS

37180		5" ID x 1" (12.7cm x 3.8cm)
37181		6" ID x 1" (15.2cm x 3.8cm)
37182		7" ID x 1" (17.8cm x 3.8cm)
37183		8" ID x 1" (20.3cm x 3.8cm)
37184		9" ID x 1" (22.9cm x 3.8cm)
37185	37185-AS	10" ID x 1" (25.4cm x 3.8cm)
37186		11" ID x 1" (27.9cm x 3.8cm)
37187	37187-AS	12" ID x 1" (30.5cm x 3.8cm)
37188		13" ID x 1" (33.0cm x 3.8cm)
37189	37189-AS	14" ID x 1" (35.5cm x 3.8cm)
37190		15" ID x 1" (38.1cm x 3.8cm)
37191	37191-AS	16" ID x 1" (40.6cm x 3.8cm)



ITEM# 37180

The photos are from actual production pieces and represent typical configurations. Actual final product may differ from photos shown. The specifications may change without prior notice.

CAKE PANS / RINGS & PAN EXTENDERS



ITEM# 38314



ITEM# 38316

Springform Cake Pans - Standard & Tube Cake Easy Release Latch for Quick Removable Bottom

Aluminum

Item#	Dimensions
38310	5" Top ID x 2-1/2"D (12.7cm x 6.4cm)
38311	6" Top ID x 2-1/2"D (15.2cm x 6.4cm)
38312	7" Top ID x 2-1/2"D (17.8cm x 6.4cm)
38313	8" Top ID x 2-1/2"D (20.3cm x 6.4cm)
38314	9" Top ID x 2-1/2"D (22.9cm x 6.4cm)
38315	10" Top ID x 2-1/2"D (25.4cm x 6.4cm)
38316	9-1/2" Top ID x 2-1/2"D (24.1cm x 6.4cm)

CAKE RINGS



ITEM# 23701
ITEM# 23703
ITEM# 23705
ITEM# 23707

Cake Rings* Stainless Steel

Ideal for use in Commercial Kitchens, Restaurants, Cafes, Bistros or Club Kitchens - These cake rings are fabricated from heavy duty stainless steel - Will not lose their shape even after continued use - Cake rings are ideal for the production of individual desserts, mousses, tarts, traditional & ice cream cakes

Item#	Dimensions
23701	2-3/4"ID x 1-3/8" (7.0cm x 3.5cm)
23702	3"ID x 1-3/8" (7.6cm x 3.5cm)
23703	3-1/2"ID x 1-3/8" (8.9cm x 3.5cm)
23704	4"ID x 1-3/8" (10.2cm x 3.5cm)
23705	5"ID x 1-3/8" (12.7cm x 3.5cm)
23706	6"ID x 1-3/8" (15.2cm x 3.5cm)
23707	7"ID x 1-3/8" (17.8cm x 3.5cm)
23708	8"ID x 1-3/8" (20.3cm x 3.5cm)
23709	9"ID x 1-3/8" (22.9cm x 3.5cm)
23710	10"ID x 1-3/8" (25.4cm x 3.5cm)
23711	12"ID x 1-3/8" (30.5cm x 3.5cm)
23712	14"ID x 1-3/8" (35.6cm x 3.5cm)

* Also available 1-3/4", 2", 2-3/8" and 3" high. For each height. Diameter sizes are available in one inch increments.

SHEET PAN EXTENDERS



ITEM# 38100

Sheet Pan Extenders Stainless Steel

Item#	Description	Dimensions
38100	Full Size, 13 gauge	16" x 23-3/4" x 2"
38120	Half Size, 18 gauge	10-3/4" x 15-1/2" x 2-3/8"

Cake Pans / Rings & Pan Extenders

The photos are from actual production pieces and represent typical configurations. Actual final product may differ from photos shown. The specifications may change without prior notice.



SHEET & DISPLAY PANS



Full Size Sheet Pans

Aluminum Sheet Pans

Item #	Description	Overall Size	AmPan	CM
16010*	12 gauge Sheet Pan	18 x 26 x 1		40600
16020	16 gauge Sheet Pan	18 x 26 x 1	02005†	40690
16030	18 gauge Sheet Pan	18 x 26 x 1	02004†	40800

Perforated Aluminum Sheet Pans

16110	16 gauge - bottom perforated only	18 x 26 x 1	02003†	44697
16120	18 gauge - bottom perforated only	18 x 26 x 1	02018†	44890
16130	16 gauge - perforated all over	18 x 26 x 1	02002†	44692

Hard Coat Anodized Aluminum

16210	16 gauge Anodized Sheet Pan	18 x 26 x 1		44693
-------	-----------------------------	-------------	--	-------

Aluminized Steel Sheet Pans

16222	22 gauge Aluminized band in rim	18 x 26 x 1	03009†	
-------	---------------------------------	-------------	--------	--

Bagel and Swedish Style Perforated Screens

16510±	14 gauge .094 dia. Perforated Screen	18 x 26		45135
16520±	12 gauge .081 dia. Perforated Screen	18 x 26		44850
16530‡	14 gauge .081 dia. Perforated Screen	18 x 26	03018†	

Perforated Screen - Cookie Sheet Style - Wire in Rim

16610**	16 gauge Perforated Screen	18 x 26		44800
16612**	16 gauge Perforated Screen	20 x 30		

* Sanitary Open Bead.

± Ends turned up

† Legacy items

** Wire in Rim - Cookie Sheet Style

‡ Sides turned up

Note: All aluminum pans come unglazed. Please call for glazed pan orders.

Half Size and Special Sheet Pans

Aluminum Sheet Pans

Item #	Description	Overall Size	AmPan	CM
16310	18 gauge Half Sheet Pan	18 x 13 x 1	02007†	40850
16320	14 gauge Half Sheet Pan	18 x 13 x 1		40950

Perforated Aluminum Sheet Pans

16350	18 gauge - bottom perforated only	18 x 13 x 1		40857
-------	-----------------------------------	-------------	--	-------

Hard Coat Anodized Aluminum

16330	14 gauge Anodized Half Pan	18 x 13 x 1		40952
-------	----------------------------	-------------	--	-------

Aluminized Steel Sheet Pans

16340	26 gauge Aluminized Half Pan	18 x 13 x 1		
-------	------------------------------	-------------	--	--

Display Pans - Gold Anodized Aluminum - Semi-curved Rim

16410	16 gauge Gold Display Pan	18 x 26 x 1	06005†	40910
16420	16 gauge Gold Display Pan	9 x 26 x 1	06003†	40920
16430	16 gauge Gold Display Pan	12 x 18 x 1	06004†	40930
16440	16 gauge Gold Display Pan	9-1/2 x 13 x 1		40940

Display Pans - Silver Anodized Aluminum - Semi-curved Rim

16415	16 gauge Silver Display Pan	18 x 26 x 1		40917
16425	16 gauge Silver Display Pan	9 x 26 x 1		40927
16445	16 gauge Silver Display Pan	9-1/2 x 13 x 1		40947

† Legacy items



ITEM# 16010



ITEM# 16110



ITEM# 16610



ITEM# 16310

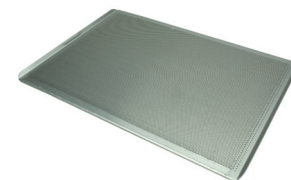

ITEM# 16350



ITEM# 16320



ITEM# 16410



ITEM# 16420

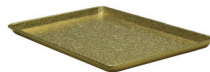

ITEM# 16430



ITEM# 16440



ITEM# 16415



ITEM# 16425



ITEM# 16445



ITEM# 16330

The photos are from actual production pieces and represent typical configurations. Actual final product may differ from photos shown. The specifications may change without prior notice.

PANS & TRAYS



Perforated Screens / Cookie Sheets

BAKER PRO SERIES SCREENS

Perforated Flat Screen Aluminum Frame Overall Dimensions: 26" x 18" x 7/16"

Item#	Configuration
#16610-BP-PSR-NC	Surface Riveted
#16610-BP-PSR-AN	Surface Riveted
#16610-BP-PSR-SG	Surface Riveted
#16610-BP-PSR-TEF	Surface Riveted

Solid Bake Surface Aluminum Frame Overall Dimensions: 26" x 18" x 7/16"

Item#	Configuration
#16610-BP-SSR-NC	Surface Riveted
#16610-BP-SSR-AN	Surface Riveted
#16610-BP-SSR-SG	Surface Riveted
#16610-BP-SSR-TEF	Surface Riveted

Perforated Flat Screen Aluminum Frame Overall Dimensions: 26" x 18" x 7/16"

Item#	Configuration
#16610-BP-PRL-NC	Rivetless
#16610-BP-PRL-AN	Rivetless
#16610-BP-PRL-SG	Rivetless
#16610-BP-PRL-TEF	Rivetless

Solid Bake Surface Aluminum Frame Overall Dimensions: 26" x 18" x 7/16"

Item#	Configuration
#16610-BP-SRL-NC	Rivetless
#16610-BP-SRL-AN	Rivetless
#16610-BP-SRL-SG	Rivetless
#16610-BP-SRL-TEF	Rivetless

Coating options:
 NC - No Coating
 AN - Anodized
 SG - Silicone Glaze
 TEF - Teflon® Coating

Teflon® color options:
 BR - Brown
 BK - Black
 BL - Blue
 TN - Tan

Storage Trucks & Dollies for All Size Trays Available

*Industrial Screens & Flat Trays:
 Ideal for Retail, Wholesale, and Large Production Operations*

SPECIFICATIONS:

- Aluminum or Stainless Steel Frame Available
- Available With Perforated or Solid Bake Surface
- Custom Sizes & Perforation Patterns Available
- Trays Are Shipped Packaged In Cartons
- Trays can be Ordered with No-Coating, Anodized, Silicone Glaze or Non-Stick Teflon® - 5,000 Plus Bake Cycles

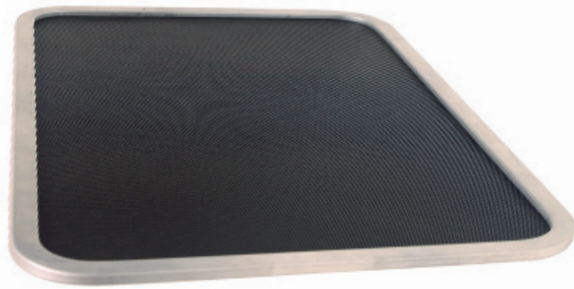

Coated Perforated Rivetless

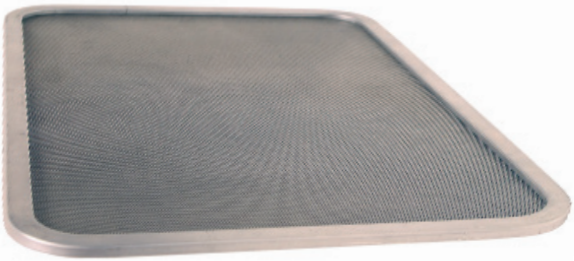

Uncoated Perforated Rivetless

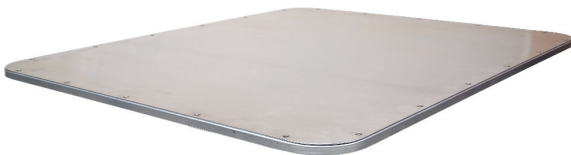

Solid Bake Surface Riveted to Frame

The photos are from actual production pieces and represent typical configurations. Actual final product may differ from photos shown. The specifications may change without prior notice.

SAFETY & MAINTENANCE INFORMATION

General Safety / Maintenance Information:

Users are responsible for the proper operation and maintenance of the equipment they use. Some equipment will quickly become damaged and unsafe if abused or subjected to improper demands. If equipment is regularly maintained and not abused, you will get the maximum safety and service performance from your casters.

- Do not overload equipment.
- Do not drop heavy loads on carts or trucks.
- Do not drop equipment from docks or forklifts while transporting, moving or loading/unloading.
- Do not use at high speeds.

These uses create severe impact and shock loads that may lead to caster, wheel and equipment failure.

Check Equipment Frames & Fasteners

Periodically turn equipment on its end or side and check the following:

- Look for broken welds or deck boards.
- Tighten loose nuts and bolts.
- Look for equipment frame distortion caused by overloads and impact loads. Distorted frames can lead to wheel failure by placing disproportionate loads on one or two casters.
- If casters are stem types, make sure that the legs of the equipment are not bent and that mounting bolts are securely fastened.
- Always use locknuts or lock washers to mount casters to equipment.
- Make certain casters with expanding adapter stems are held firmly in place in tubular equipment.

Caster & Wheel Lubrication

Caster and wheel lubrication is essential. The lubrication schedule depends on your specific application. Normal conditions may warrant lubrication every six months. However, for wet or corrosive applications, monthly lubrication may be required. Lubrication may also be required after each cart washing. Special high temperature, water resistant lubricants must be used for this application. Ineqco can provide stainless steel casters that require less maintenance in frequent cart washing application.

Caster Maintenance & Inspection

Check the swivel assembly for excessive play due to wear. If the swivel assembly is loose, it is advisable to replace the fork or the entire caster. If the caster has king bolt and nut, make sure it is fastened securely. If the swivel does not turn freely, check the corrosion or dirt binding the raceways. Again, it may be necessary to replace the swivel assembly or the entire caster. If the equipment has rigid casters at one end, make sure that casters fork legs are not bent or distorted.

Wheel Maintenance & Inspection

Check wheels for visible tread wear. Flat spots may indicate accumulation of floor debris such as string or thread which can cause the wheel to bind. Remove the wheel axle bolt and nut. Clean out foreign material and check wheel bearings for wear or failure. Re-assemble if parts are not damaged. Wheel thread guards may be installed to reduce buildup if string and thread wrapping is a continuing problem. After wheels have been inspected and repaired or replaced, be sure the axle nut is properly tightened. Use lock washer or lock nuts on all axles. **Note: Axle nuts with thread locking dimples must be replaced because after initial unscrewing it loses its self locking property.**

Brake Maintenance & Inspection

Check brakes for proper operation. It is recommended that scaffold caster brakes be tested daily or before each use of the equipment. Apply brakes one at a time and attempt to move the equipment to make sure that each brake is not slipping or loose. If brake slip due to worn or damaged wheels, replace the wheels immediately and retest the brakes. If the brake mechanism itself is not operating properly, repair or replace it. Before returning the equipment to use, always retest brakes.

Power Towed Operation

Power drawn equipment such as in a tow line or mechanically moved by conveyor will require casters, wheels and bearings specifically designed for this use. Please consult factory for caster recommendation for each specific towing or power drawn equipment application.

Washing Racks

Wash with Mild Soap and Water, Use only Commercial Cleaning Product that is Base Metal Friendly. Do Not Use Metal or Sharp Objects that could Scratch the Base Metal and Damage the New Like Appearance. Contact our experienced sales and engineering staff for any additional assistance you may need.

The photos are from actual production pieces and represent typical configurations. Actual final product may differ from photos shown. The specifications may change without prior notice.



RELEASE COATINGS INFORMATION

Release Coating

Several coatings are available to improve the baked product appearance, and help release the product from the baking pan. We provide here a short explanation about each one of them. In all cases, if the use of the specific coating is a new experience, we recommend a full field test before committing to any specific technology; the performance of the coating may vary with the sugar content of the loaf, water percentage, and other factors. We can always recommend the most appropriate coating in each case.

Note: All our coatings confirm to European, US, and International Regulations for food grade material.

Silicone Glazing

This is the most popular coating among American bakers. It consists of a layer of silicon resin that is applied to the surface of the pan, and then cured under special temperature conditions; the coating then turns to a slightly shiny, very smooth surface. This coating can be combined with an earlier preparation of the base surface to turn the base metal (usually aluminized steel) into a darker color. This will improve the heat properties of the pan. The darker color is mostly used in proof and bake systems. The glazing life consists usually of 300 cycles, after which the pan can be reglazed.

- *Helps keep pans clean.*
- *Helps release the baked product, eliminating or reducing pan greasing.*
- *This is usually the coating of choice when the product to be baked contains a large percentage of sugar.*

Silicone Rubber

French style redish orange rubber coating, which is very well suited for Hamburger, Baguette and Hot Dog type pans, where the cavities or molds do not have tall vertical walls that would increase depanning friction. The durability varies with the product, but it is typically at least three to five times that of glazing; it is typical to have between 1200 and 2000 oven cycles in low friction pans.

PTFE Coating

Very popular hard coat, used by wholesale bakers to completely eliminate the need for greasing, and improve bakery production speed.

- *Provides a very long life span, adapted to friction prone pans.*
- *The typical number of release cycles with this coating is around 3000-5000 with low sidewalls, and 2000 cycles for Bread and Pullman pans.*

Note: Final bake cycles achieved will greatly depend on the type of product, pan handling, cleaning, etc. and the above cycle count is provided for informational purpose only, separate study should be done for each application to find the actual performance of the coating.

Guidelines for the Care of Pans and the Glaze Coating

Daily Use.

• Lubricate Pans

Apply a baking pan lubricant to the baking areas of the pan as needed. Bread products may only require lubricant before the first bake and after washing. Cake products will most likely require pan lubricant with every bake..

• De-Pan Products Quickly

Baked products should be de-panned while the pan is still hot or warm. If baked products are allowed to cool in the pan, steam from the product will penetrate the glaze and may cause glaze lifting, premature glaze failure and damage to the pan's surface.

• Do Not Scratch or Scrape Pans

Do not use metal utensils or other objects that could scratch the glaze. Deep scratches may cause surface corrosion on the pan.

Daily Cleaning

• Clean After Each Use

Wiping still warm pans with a clean towel, or a towel that has pan lubricant on it, usually provides adequate cleaning. Avoid washing when ever possible.

• Wash with Mild Soap and Water

Commercial baking pans can be washed with pH-neutral products, but only when absolutely necessary. Do not use acidic cleansers, alkaline detergents or abrasive scrubbing pads. Use of these materials will cause the glaze to fail prematurely and may cause corrosion.

Do not soak pans in water. Do not wash in automatic washers.

• Thoroughly Dry Pans Immediately After Washing

Warm ovens work best.

• Dry and Store Pans Upside Down

Do not nest pans immediately after towel drying. Keep pans away from moist and humid storage environments. The best storage areas are dry, warm storage areas or still warm ovens.

The photos are from actual production pieces and represent typical configurations. Actual final product may differ from photos shown. The specifications may change without prior notice.

CUSTOM AND SPECIAL ORDERS



Custom Equipment for your Specific Application

Magna Industries for over 30 years:

Specializes designing custom equipment for Retail, Wholesale, and Large Production Operations that transforms concepts in to solutions.

Employs highly skilled engineers and designers, has fully equipped computerized and robotic machine shop, a sheet metal shop, and a welding shop that will design the perfect solution for your custom needs.

Provides our customers with custom engineered solution, specifically created for their particular application.

Today more then ever Magna Industries is proud to offer following solutions and products to our loyal customer base:

- Start to Finish Planning
- Designing
- Manufacturing
- Service and Support
- Custom Configurations and Fabrications
- Work with variety of materials
- On-Site Assistance
- Engineering and Designing to Fit Customer Specifications
- Highly Trained Technicians
- Robotic Welding
- Maintenance and Safety

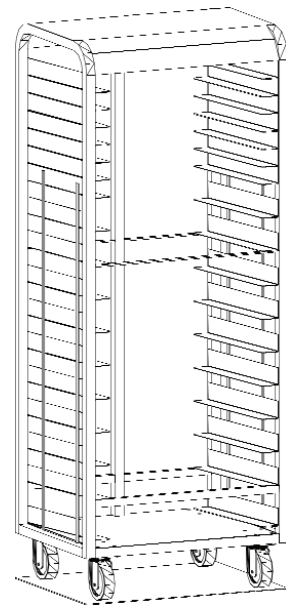
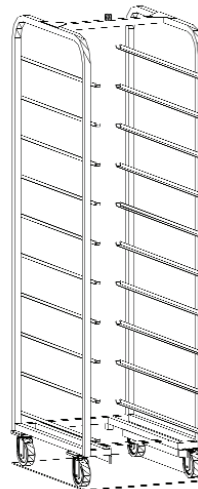
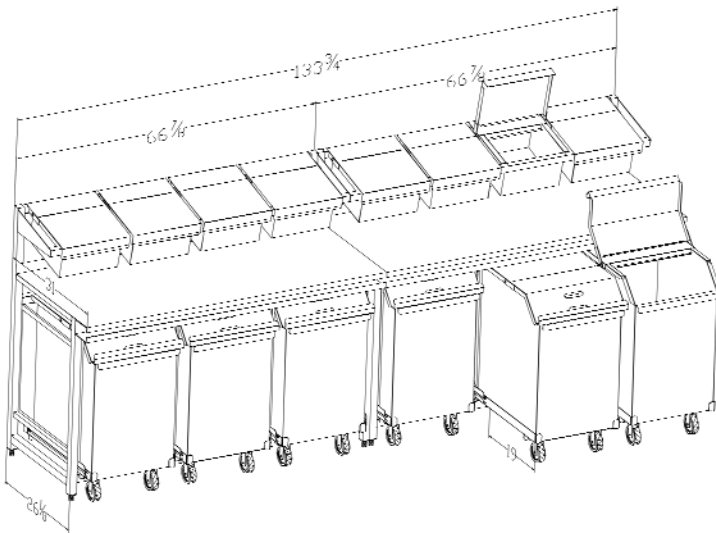
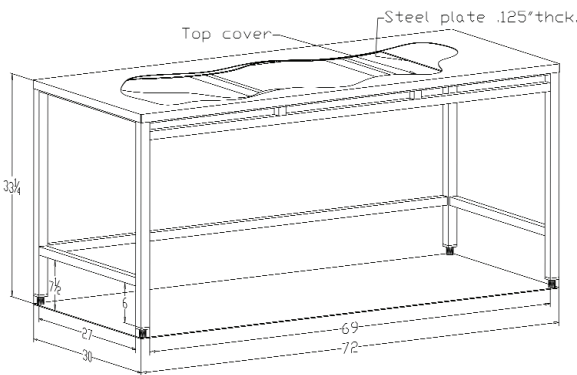
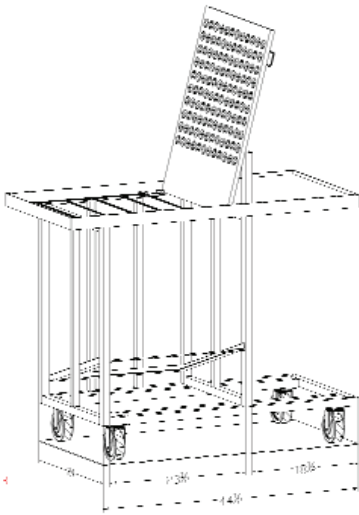

Custom and Special Orders



The photos are from actual production pieces and represent typical configurations. Actual final product may differ from photos shown. The specifications may change without prior notice.

CUSTOM AND SPECIAL ORDERS

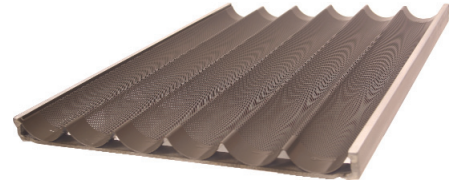

Custom and Special Orders

With great gratitude to our customers we are committed to take all of our experience and traditional values in manufacturing, combining them with new technologies to build better products with the same traditional philosophy while giving our customers the most value for their money along with the best service.

The photos are from actual production pieces and represent typical configurations. Actual final product may differ from photos shown. The specifications may change without prior notice.



HOW TO ORDER

Order Toll-Free by calling 1-(800)-510-9856
Order by Faxing Purchase Order 1-(732)-367-2989
Place an order or obtain information by calling 1-732-905-0957
Order Online at: www.magnaindustries.com or email a request to sales@magnaindustries.com

To contact us directly:
Magna Industries Inc
1825 Swarthmore Avenue, Lakewood, NJ 08701
1-(800)-510-9856 · (732)-905-0957 · FAX: (732)-367-2989

Minimum Orders:
Minimum order charge is \$25.

New Accounts:
Please submit 3 credit references, bank information with telephone number and contact, and your Dun & Bradstreet number. We require your Federal ID number or owner's Social Security number and a copy of your Sales Tax Exemption Certificate when applicable. Please allow 7-14 days for new account processing.

Specifications:
Specifications are subject to change without notice.

Terms:
Net 30 days on open accounts from date of invoice. Open accounts will only be established upon receipt of satisfactory credit references.

Damaged or Lost Shipments:
We are not responsible for merchandise damage while in the hands of the carrier. For damage and/or loss in transit, Buyer must file claim against carrier, write on the Bill of Lading that the items received are damaged. Failure to do so may result in a claim decline by the carrier. Keep all damaged goods, all shipping containers and packaging for future inspection by the carrier.

Returns:
To return merchandise you must receive a Return Authorization Number. Merchandise is to be returned with transportation charges prepaid, maximum 25% restocking charge applies. Special/Custom orders are not returnable or refundable.

Feedback:
Your feedback is very important to us. If you have any compliments, complaints, or suggestions about our products and services or anything you would like to share with us about your experience with Magna Industries Inc. please email us at sales@magnaindustries.com.

MAGNA INDUSTRIES INC. LIMITED WARRANTY

Outside the USA

Magna Industries Inc. warrants to the original purchaser, on equipment manufactured by Magna Industries, for a period of one (1) year replacement of defective parts only. No labor will be covered.

USA Warranty

Magna Industries Inc., warrants to the original purchaser equipment manufactured by Magna Industries Inc., (hereinafter Magna), for a period of one (1) year, and any labor cost(s) pertaining to the replacement or repair of said defective part will be covered by Magna, for a period of not more than ninety (90) days, both from the original date of shipment from Magna's warehouse.

The Purchaser is responsible for proper installation, operation under normal conditions with proper supervision, and the performance of preventative maintenance. Magna's obligation under this warranty shall be for the replacement or repair of said defective parts within the above mentioned warranty period. After thorough examination and inspection, decision of Magna's Service Department and/or Magna's Authorized Service Agencies shall be final. The procedure for part(s) replacement during the warranty period is as follows:

1. Magna will ship and invoice new parts to the original Purchaser with Return Authorization Number.
2. Credit for the new parts will be issued after receipt and inspection of old part(s).
3. All shipping charges for the return of these parts is the responsibility of the Purchaser.
4. Return Authorization Number must be marked on returned goods package(s). All returned defective parts must be properly packed and tagged, stating serial number, model number, invoice number and date, before shipment to:

Magna Industries Inc.
1825 Swarthmore Avenue
Lakewood, NJ 08701

Magna will not, however, assume any responsibility for any expenses (including labor) incurred in the field incidental to the repair or replacement of equipment covered by this warranty or from the obtainment of the above information.

Magna's obligation hereunder to repair or replace defective part(s) is the exclusive remedy for breach of this warranty; and Magna will not be liable for any other damages or claims, including consequential damages. Magna will not honor any warranty for defective parts and labor should the Purchaser change the condition of the equipment originally shipped in any way.

No representative, dealer, distributor or any other person is authorized or permitted to make any other warranties or obligate Magna to any liability that is not in strict accordance with this policy.

THIS WARRANTY IS IN LIEU OF ALL OTHER WARRANTIES, WHETHER EXPRESSED OR IMPLIED, INCLUDING ANY WARRANTY OR MERCHANTABILITY, AND FITNESS FOR A "PARTICULAR" PURPOSE AND MAGNA DOES NOT HEREBY EXCLUDE AND SHALL NOT BE LIABLE TO PURCHASER FOR ANY CONSEQUENTIAL OR INCIDENTAL DAMAGES INCLUDING, BUT NOT LIMITED TO DAMAGE TO PROPERTY, DAMAGES FOR LOSS OF USE, LOSS OF TIME, LOSS OF PROFIT OR INCOME RESULTING FROM ANY BREACH OF WARRANTY.

This warranty is valid only for items manufactured by Magna Industries.

INDEX BY ITEM NUMBER

ITEM	PAGE	ITEM #	PAGE	ITEM #	PAGE	ITEM #	PAGE	ITEM	PAGE	ITEM #	PAGE	ITEM #	PAGE
10051	41	1042	31	10506	19	11430-BP-AN	49	1410	42	15620	52	1818KD	5
10172	17	1043	31	10507	19	11430-BP-NC	49	1410-1	42	15630	52	1818-P	2
10179	45	1044	31	10508	19	11430-BP-SG	49	1411	42	15710	52	1819E	4
10179-5	45	1045	31	10509	19	11430-BP-TEF	49	14110	48	15720	52	1819KD	5
1028	31	10450	31	1051	31	11440-BP-AN	49	14220	47	15730	52	1819-P	2
1029	31	10451	31	10510	19	11440-BP-NC	49	14310	48	16010	55	1820E	4
1030	31	10452	31	10511	19	11440-BP-SG	49	14320	48	16020	55	1820KD	5
10300	34	10453	31	10512	19	11440-BP-TEF	49	1454	31	16030	55	1820-P	2
10301	34	10454	31	10513	19	11450-BP-AN	49	1455	31	16110	55	1821E	4
10302	34	10455	31	10514	19	11450-BP-NC	49	14590	48	16120	55	1821KD	5
10303	34	10456	31	10515	19	11450-BP-SG	49	14610	48	16130	55	1821-P	2
10304	34	10457	31	10516	19	11450-BP-TEF	49	14620	48	16210	55	18400_TR_1_BK_FT	50
10305	34	10458	31	10517	19	1200-PL	26	14630	48	16222	55	18400_TR_1_BL_FT	50
10306	34	10459	31	10518	19	1266	45	14640	48	16310	55	18400_TR_1_BR_FT	50
10307	34	1046	31	10519	19	1266-2	45	14650	48	16320	55	18400_TR_1_TN_FT	50
1031	31	10460	31	1052	31	1266-RGD	45	14660	48	16330	55	18400_TR_2_BK_FB	50
1032	31	10461	31	10525	12	1277E	3	14670	48	16340	55	18400_TR_2_BL_FB	50
10320	34	10462	31	10526	12	1277KD	5	14680	48	16350	55	18400_TR_2_BR_FB	50
10321	34	10463	31	1053	31	1277-P	1	14700	48	16410	55	18400_TR_2_TN_FT	50
10322	34	10464	31	10545	12	13010	46	1481	42	16415	55	18400_TR_2_BK_RB	50
10323	34	10465	31	10546	12	13020	46	14810	48	16420	55	18400_TR_2_BL_RB	50
10324	34	10466	31	10547	12	13030	46	14820	48	16425	55	18400_TR_2_BR_RB	50
10325	34	10467	31	10548	12	13032	46	14830	48	16430	55	18400_TR_2_TN_RB	50
10326	34	10468	31	10584	11	13040	46	14840	48	16440	55	18400_TR_3_BK_FB	50
10327	34	10469	31	10584-1	11	13050	46	14850	48	16445	55	18400_TR_3_BL_FB	50
1033	31	1047	31	10584-2-SS	11	13060	46	14860	48	16510	55	18400_TR_3_BR_FB	50
1034	31	10470	31	10585	11	13070	46	14880	48	16520	55	18400_TR_3_TN_FB	50
10340	34	10471	31	10618	44	13080	46	14890	48	16530	55	18400_TR_3_BK_RB	50
10341	34	10472	31	10654	20	13090	46	14895	48	16610	55	18400_TR_3_BL_RB	50
10342	34	10473	31	10654-AS	20	1310	44	15110	51	16610-BP-PRL-AN	56	18400_TR_3_BR_RB	50
10343	34	10474	31	10654-HR	20	13210	46	15120	51	16610-BP-PRL-NC	56	18400_TR_3_TN_RB	50
10344	34	10475	31	1068-GR	45	13220	46	15130	51	16610-BP-PRL-SG	56	18400_TR_4_BK_FB	50
10345	34	10476	31	10903	43	13230	46	15140	51	16610-BP-PRL-TEF	56	18400_TR_4_BL_FB	50
10346	34	10477	31	10928	13	13240	46	15150	51	16610-BP-PSR-AN	56	18400_TR_4_BR_FB	50
10347	34	10478	31	1100	31	1331-18	44	15210	51	16610-BP-PSR-NC	56	18400_TR_4_TN_FB	50
1035	31	10479	31	1101	31	13310	46	15220	51	16610-BP-PSR-SG	56	18400_TR_4_BK_RB	50
1036	31	1048	31	1102	31	13320	46	15230	51	16610-BP-PSR-TEF	56	18400_TR_4_BL_RB	50
10360	34	10480	31	1103	31	13330	46	1524	31	16610-BP-SRL-AN	56	18400_TR_4_BR_RB	50
10361	34	10481	31	1104	31	13340	46	15240	51	16610-BP-SRL-NC	56	18400_TR_4_TN_RB	50
10362	34	10483	12	1105	31	13350	46	15250	51	16610-BP-SRL-SG	56	18500_TR_1_BK_FT	50
10363	34	10484	12	1106	31	13360	46	1526-1.5	45	16610-BP-SRL-TEF	56	18500_TR_1_BL_FT	50
10364	34	10485	12	1107	31	13370	46	1526-1.625	45	16610-BP-SSR-AN	56	18500_TR_1_BR_FT	50
10365	34	10486	12	1108	31	13380	46	15260	51	16610-BP-SSR-NC	56	18500_TR_1_TN_FT	50
10366	34	10487	12	1109	31	1339	42	15310	51	16610-BP-SSR-SG	56	18500_TR_2_BK_FB	50
10367	34	10488	12	1110	31	13390	46	15312	51	16610-BP-SSR-TEF	56	18500_TR_2_BL_FB	50
10369	45	1049	31	1111	31	13392	46	15320	51	16612	55	18500_TR_2_BR_FB	50
1037	31	10491	18	1112	31	13510	46	15322	51	1698	45	18500_TR_2_TN_FB	50
10376	44	10492	18	1113	31	13520	46	15330	51	1698-5-16-BL	45	18500_TR_2_BK_RB	50
1038	31	10493	18	1114	31	13530	46	15332	51	1699	45	18500_TR_2_BL_RB	50
10380	34	10494	18	1115	31	13540	46	15334	51	1699-5-16-BL	45	18500_TR_2_BR_RB	50
10381	34	10495	22	1116	31	13610	46	15336	51	1699-NGF	45	18500_TR_2_TN_RB	50
10382	34	10495DBL	22	1117	31	13620	46	15338	51	1700	45	18500_TR_3_BK_FB	50
10383	34	10495SDBL	22	1118	31	1364-PL	26	15340	51	1813E	3	18500_TR_3_BL_FB	50
10384	34	10496	22	1119	31	1365	43	15342	51	1813KD	5	18500_TR_3_BR_FB	50
10385	34	10496T	22	1120	31	1365-HP	43	15344	51	1813-P	1	18500_TR_3_TN_FT	50
10386	34	10496THD	22	1121	31	1366	43	15350	51	1814E	3	18500_TR_3_BK_RB	50
10387	34	10497	22	1122	31	13710	47	15352	51	1814KD	5	18500_TR_3_BL_RB	50
1039	31	10497T	22	1123	31	13720	47	15360	51	1814-P	1	18500_TR_3_BR_RB	50
1040	31	10497THD	22	1124	31	13730	47	15362	51	1815E	3	18500_TR_3_TN_RB	50
10400	34	10498	19	1125	31	13740	47	15364	51	1815KD	5	18500_TR_4_BK_FB	50
10401	34	10499	19	11410-BP-AN	49	13810	47	15366	51	1815-P	1	18500_TR_4_BL_FB	50
10402	34	1050	31	11410-BP-NC	49	13820	47	1541-18	44	1816E	3	18500_TR_4_BR_FB	50
10403	34	10500	19	11410-BP-SG	49	13830	47	15410	51	1816KD	5	18500_TR_4_TN_FB	50
10404	34	10501	19	11410-BP-TEF	49	13840	47	15420	51	1816-P	1	18500_TR_4_BK_RB	50
10405	34	10502	19	11420-BP-AN	49	13850	47	15430	51	1817E	4	18500_TR_4_BL_RB	50
10406	34	10503	19	11420-BP-NC	49	13860	47	15510	52	1817KD	5	18500_TR_4_BR_RB	50
10407	34	10504	19	11420-BP-SG	49	14010	47	15520	52	1817-P	2	18500_TR_4_TN_RB	50
1041	31	10505	19	11420-BP-TEF	49	14020	47	15610	52	1818E	4	18600_TR_1_BK_FT	50

Index by Item Number



INDEX BY ITEM NUMBER

ITEM #	PAGE	ITEM #	PAGE	ITEM #	PAGE	ITEM #	PA	ITEM #	PA	ITEM #	PAGE
18600_TR_1_BL_FT....	50	19300-3-AL.....	15	21375	22	22968-SL	39	2310-GR	45	23824	13
18600_TR_1_BR_FT....	50	19300-5-AL.....	15	21375-S	22	22969	39	2310-GR-HLW ...	45	23825	13
18600_TR_1_TN_FT....	50	19300-6-AL.....	15	2155	45	22969-SL	39	2310-GR-SS....	45	23830	13
18600_TR_2_BK_FB....	50	20120	22	21958-18	44	22970	11	2311	45	23831	13
18600_TR_2_BL_FB....	50	20131	44	22019	11	22971	11	23239	20	23832	13
18600_TR_2_BR_FB....	50	20140-3W.....	26 & 42	2208	45	22972	11	23239-26	20	23833	13
18600_TR_2_TN_FB....	50	20140-6BL.....	26 & 42	2208-2	45	22973.....	11	2324	44	23834	13
18600_TR_2_BK_RB....	50	20140-6GY.....	26 & 42	2208-LT	45	22974.....	11	2324-36.....	44	23835	13
18600_TR_2_BL_RB....	50	20140-6RD.....	26 & 42	22188.....	17 & 44	22980.....	11	2326	44	2392	45
18600_TR_2_BR_RB....	50	20140-6WH.....	26 & 42	22189.....	17 & 44	22981.....	11	23317.....	26	23980-SS-10-MOD1	40
18600_TR_2_TN_RB....	50	20140-8BL.....	26 & 42	22191.....	17 & 44	22982.....	11	23318.....	26	23980-SS-12-MOD1	40
18600_TR_3_BK_FB....	50	20140-8GY.....	26 & 42	22282	13	22983.....	11	23319.....	26	23980-SS-15-MOD1	40
18600_TR_3_BL_FB....	50	20140-8RD.....	26 & 42	22318-D09	21	22984.....	11	23320.....	26	23980-SS-18-MOD1	40
18600_TR_3_BR_FB....	50	20140-8WH.....	26 & 42	22318-D11	21	23020A-NL	38	23321.....	26	23980-SS-20-MOD1	40
18600_TR_3_TN_FB....	50	20279-END.....	17 & 44	22318-D14	21	23021A-NL	38	23322.....	26	23980-10-MOD1	40
18600_TR_3_BK_RB....	50	20279-INT.....	17 & 44	22318-D18	21	23022A-NL	38	23429-3B.....	26	23980-12-MOD1	40
18600_TR_3_BL_RB....	50	2026E	3	22318-D25	21	23023A-NL	38	23429-6B.....	26	23980-15-MOD1	40
18600_TR_3_BR_RB....	50	2026-P	1	22318-S09	21	23024A-NL	38	23429-8B.....	26	23980-18-MOD1	40
18600_TR_3_TN_RB....	50	2027E	3	22318-S11	21	23030.....	15	23429-3B-XX	26	23980-20-MOD1	40
18600_TR_4_BK_FB....	50	2027-P	1	22318-S14	21	23030A-NL	38	23429-6B-XX	26	23990-SS-10	40
18600_TR_4_BR_FB....	50	2028E	3	22318-S18	21	23030-SS	15	23429-8B-XX	26	23990-SS-14	40
18600_TR_4_BR_FB....	50	2028-P	1	22318-S25	21	23031.....	15	23429S-3B.....	26	23990-SS-15	40
18600_TR_4_TN_FB....	50	2029E	3	2234	9	23031A-NL	38	23429S-6B.....	26	23990-SS-17	40
18600_TR_4_BK_RB....	50	2029-P	1	2234D-M	10	23031-SS	15	23429S-8B.....	26	23990-SS-20	40
18600_TR_4_BL_RB....	50	2030E	3	2234-M	10	23032A-NL	38	23429S-3B-XX	26	23990-10	40
18600_TR_4_BR_RB....	50	2030-P	1	2237	30	23033A-NL	38	23429S-6B-XX	26	23990-14	40
18600_TR_4_TN_RB....	50	2031E	4	2238	30	23034A-NL	38	23429S-8B-XX	26	23990-15	40
18600_TR_5_BK_FB....	50	2031-P	2	22433	52	23040A-NL	38	2364	44	23990-17	40
18600_TR_5_BL_FB....	50	2032E	4	22440	39	23041A-NL	38	23701	54	23990-20	40
18600_TR_5_BR_FB....	50	2032-P	2	22441	39	23042A-NL	38	23702	54	2407	44
18600_TR_5_TN_FB....	50	2033E	4	22442	39	23043A-NL	38	23703	54	2467	45
18600_TR_5_BK_RB....	50	2033-P	2	22443	39	23044A-NL	38	23704	54	2492	9
18600_TR_5_BL_RB....	50	2034E	4	22444	39	23050S-NL	38	23705	54	2492D-M.....	10
18600_TR_5_BR_RB....	50	2034-P	2	22445	39	23051S-NL	38	23706	54	2492-M.....	10
18600_TR_5_TN_RB....	50	2035E	4	22446	39	23052S-NL	38	23707	54	2500-26	35
1890	30	2035-P	2	22447	39	23053S-NL	38	23708	54	25011-FLR	44
19170	44	2036	30	22448	39	23054S-NL	38	23709	54	2501-26	35
19171	44	20370N-10-SP	40	22449	39	23060S-NL	38	23710	54	25012-FLR	44
19172	44	20370N-12-SP	40	2251	22	23061S-NL	38	23711	54	25013-FLR	44
19173	44	20370N-15-SP	40	22808	52	23062S-NL	38	23712	54	25014-FLR	44
19174	44	20370N-18-SP	40	22948	52	23063S-NL	38	23721	14	25017-FLR	44
19175	44	20370N-20-SP	40	22950	39	23064S-NL	38	23722	14	25020-FLR	44
19176	44	20370N-25-SP	40	22951	39	23070S-NL	38	23723	14	2502-26	35
19177	44	20370N-30-SP	40	22952	39	23071S-NL	38	23724	14	25023-FLR	44
19178	44	20370N-AL-10-SP	40	22953	39	23072S-NL	38	23725	14	2503-26	35
19179	44	20370N-AL-12-SP	40	22954	39	23073S-NL	38	23725-5	14	2504-26	35
19180	44	20370N-AL-15-SP	40	22955	39	23074S-NL	38	23726	14	2505-26	35
19181	44	20370N-AL-18-SP	40	22956	39	23080	39	23727	14	2506-26	35
19182	44	20370N-AL-20-SP	40	22957	39	23080-SL	39	23728	14	2507-26	35
19183	44	20370N-AL-25-SP	40	22958	39	23081	39	23731	14	2508-26	35
19184	44	20370N-AL-30-SP	40	22959	39	23081-SL	39	23732	14	2509-26	35
19184-SS	44	2040	30	22960	39	23082	39	23733	14	2510	35
19185	44	2041	30	22960-SL	39	23082-SL	39	23734	14	2511	35
19185-SS	44	2060	30	22961	39	23083	39	23735	14	2512	35
19186	44	20655	24	22961-SL	39	23083-SL	39	23735-5	14	2513	35
19186-AL	44	20656-B	24	22962	39	23084	39	23736	14	2514	35
19187	17 & 44	20656-G	24	22962-SL	39	23084-SL	39	23737	14	25147-FLR	44
19190.....	17 & 44	20666-2	24	22963	39	23085	39	23738	14	2515	35
19215-3	20	20666-3	24	22963-SL	39	23085-SL	39	23810	13	2516	35
19215-3-PC	20	20767	24	22964	39	23086	39	23811	13	2517	35
19215-4	20	20790-06	16	22964-SL	39	23086-SL	39	23812	13	2518	35
19215-4-PC	20	20790-06-SS	16	22965	39	23087.....	39	23813	13	2519	35
19215-9	20	20790-16	16	22965-SL	39	23087-SL	39	23814	13	25197-FLR	44
19215-9-PC	20	20790-16-SS	16	22966	39	23088.....	39	23815	13	2520	35
19275	42	20790-20	16	22966-SL	39	23088-SL	39	23820	13	2521	35
19300-3.....	15	20790-20-SS	16	22967	39	23089.....	39	23821	13	2522	35
19300-5.....	15	2083	22	22967-SL	39	23089-SL	39	23822	13	2523	35
19300-6.....	15	2083T	22	22968	39	2310-2-GR....	45	23823	13	25235-FLR	44



INDEX BY ITEM NUMBER

ITEM #	PAGE	ITEM #	PAGE	ITEM #	PAGE	ITEM #	PAGE	ITEM #	PAGE	ITEM #	PAGE	ITEM #	PAGE
2524	35	2592-26	36	2660	37	2728	37	2796	36	2864	37	37151-AS	53
2525	35	2593-26	36	2661	37	2729	37	2797	36	2865	37	37152	53
2526	35	2594-26	36	2662	37	2730	38	2798	36	2866	37	37153	53
2527	35	2595-26	36	2663	37	2731	38	2799	36	2867	37	37153-AS	53
2528	35	2596-26	36	2664	37	2732	38	2800	36	2868	37	37154	53
2529	35	2597-26	36	2665	37	2733	38	2801	36	2869	37	37154-AS	53
2530-36	35	2598-26	36	2666	37	2734	38	2802	36	2886	45	37155	53
2531-36	35	2599-26	36	2667	37	2735	38	2803	36	3000-26	35	37156	53
2532-36	35	2600	36	2668	37	2736	38	2804	36	3001-26	35	37157	53
2533-36	35	2601	36	2669	37	2737	38	2805	36	3002-26	35	37158	53
2534-36	35	2602	36	2670-26	37	2738	38	2806	36	3003-26	35	37159	53
2535-36	35	2603	36	2671-26	37	2739	38	2807	36	3004-26	35	37160	53
2536-36	35	2604	36	2672-26	37	2740	38	2808	36	3005-26	35	37161	53
2537-36	35	2605	36	2673-26	37	2741	38	2809	36	3006-26	35	37162	53
2538-36	35	2606	36	2674-26	37	2742	38	2810	36	3007-26	35	37170	53
2539-36	35	2607	36	2675-26	37	2743	38	2811	36	3008-26	35	37171	53
2540	35	2608	36	2676-26	37	2744	38	2812	36	3009-26	35	37172	53
2541	35	2609	36	2677-26	37	2745	38	2813	36	31510	52	37173	53
2542	35	2610-36	36	2678-26	37	2746	38	2814	36	31511	52	37180	53
2543	35	2611-36	36	2679-26	37	2747	38	2815	36	31512	52	37181	53
2544	35	2612-36	36	2680	37	2748	38	2816	36	31513	52	37182	53
2545	35	2613-36	36	2681	37	2749	38	2817	36	31514	52	37183	53
2546	35	2614-36	36	2682	37	2750	35	2818	36	31515	52	37184	53
2547	35	2615-36	36	2683	37	2751	35	2819	36	31516	52	37185	53
2548	35	2616-36	36	2684	37	2752	35	2820	36	31517	52	37185-AS	53
2549	35	2617-36	36	2685	37	2753	35	2821	36	31518	52	37186	53
2550-36	35	2618-36	36	2686	37	2754	35	2822	36	31519	52	37187	53
2551-36	35	2619-36	36	2687	37	2755	35	2823	36	31520	52	37187-AS	53
2552-36	35	2620	36	2688	37	2756	35	2824	36	31521	52	37188	53
2553-36	35	2621	36	2689	37	2757	35	2825	36	3383	44	37189	53
2554-36	35	2622	36	2690-36	37	2758	35	2826	36	3641	11	37189-AS	53
2555-36	35	2623	36	2691-36	37	2759	35	2827	36	3644	11	37190	53
2556-36	35	2624	36	2692-36	37	2760	35	2828	36	3644-30	11	37191	53
2557-36	35	2625	36	2693-36	37	2761	35	2829	36	3647	11	37191-AS	53
2558-36	35	2626	36	2694-36	37	2762	35	2830	37	3648	11	3735	8
2559-36	35	2627	36	2695-36	37	2763	35	2831	37	3649	11	3735-KC3	13
2560	35	2628	36	2696-36	37	2764	35	2832	37	3650	11	3736	8
2561	35	2629	36	2697-36	37	2765	35	2833	37	3651	11	3758	45
2562	35	2630-36	36	2698-36	37	2766	35	2834	37	37000	52	38100	54
2563	35	2631-36	36	2699-36	37	2767	35	2835	37	37001	52	38120	54
2564	35	2632-36	36	2700	37	2768	35	2836	37	37002	52	38310	54
2565	35	2633-36	36	2701	37	2769	35	2837	37	37003	52	38311	54
2566	35	2634-36	36	2702	37	2770	35	2838	37	37003-1	52	38312	54
2567	35	2635-36	36	2703	37	2771	35	2839	37	37004	52	38313	54
2568	35	2636-36	36	2704	37	2772	35	2840	37	37090	52	38314	54
2569	35	2637-36	36	2705	37	2773	35	2841	37	37130	53	38315	54
2570-26	36	2638-36	36	2706	37	2774	35	2842	37	37131	53	38316	54
2571-26	36	2639-36	36	2707	37	2775	35	2843	37	37131-AS	53	38340	26
2572-26	36	2640	36	2708	37	2776	35	2844	37	37132	53	38341	26
2573-26	36	2641	36	2709	37	2777	35	2845	37	37132-AS	53	38400	23
2574-26	36	2642	36	2710-36	37	2778	35	2846	37	37133	53	38401	23
2575-26	36	2643	36	2711-36	37	2779	35	2847	37	37133-AS	53	38402	23
2576-26	36	2644	36	2712-36	37	2780	35	2848	37	37134	53	38403	23
2577-26	36	2645	36	2713-36	37	2781	35	2849	37	37134-AS	53	38404	23
2578-26	36	2646	36	2714-36	37	2782	35	2850	37	37135	53	38405	23
2579-26	36	2647	36	2715-36	37	2783	35	2851	37	37135-AS	53	38406	23
2580	36	2648	36	2716-36	37	2784	35	2852	37	37136	53	38410	23
2581	36	2649	36	2717-36	37	2785	35	2853	37	37137	53	38411	23
2582	36	2650-26	37	2718-36	37	2786	35	2854	37	37137-AS	53	38412	23
2583	36	2651-26	37	2719-36	37	2787	35	2855	37	37138	53	38413	23
2584	36	2652-26	37	2720	37	2788	35	2856	37	37139	53	38414	23
2585	36	2653-26	37	2721	37	2789	35	2857	37	37139-AS	53	38415	23
2586	36	2654-26	37	2722	37	2790	36	2858	37	37140	53	38416	23
2587	36	2655-26	37	2723	37	2791	36	2859	37	37141	53	38420	28
2588	36	2656-26	37	2724	37	2792	36	2860	37	37141-AS	53	38421	28
2589	36	2657-26	37	2725	37	2793	36	2861	37	37142	53	38422	28
2590-26	36	2658-26	37	2726	37	2794	36	2862	37	37150	53	38423	28
2591-26	36	2659-26	37	2727	37	2795	36	2863	37	37151	53	38424	28

Index by Item Number



INDEX BY ITEM NUMBER

ITEM #	PAGE	ITEM #	PAGE	ITEM #	PAGE	ITEM #	PAGE	ITEM #	PAGE	ITEM #	PAGE	ITEM #	PAGE	ITEM #	PAGE
38425	28	38519	29	39080-P	27	4094	30	5054E	42	6047-P	1	6125Z	6	6430	30
38426	28	38520	29	39081	27	4095	30	5089	42	6048E	3	6126Z	6	6431	30
38427	28	38521	29	39081-P	27	4118	44	5092	42	6048KD	5	6127Z	6	6432	30
38430	28	38522	29	39082	27	4127	9	5093	43	6048-P	1	6128Z	6	6433	30
38431	28	38523	29	39082-P	27	4127D-M	10	5098	17 & 45	6049E	3	6129Z	6	6434	30
38432	28	38530	Call	39083	27	4127-M	10	5098-5	17, 45	6049KD	5	6130Z	6	6435	30
38433	28	38531	Call	39083-P	27	4131	9	5099	43	6049-P	1	6131Z	6	6436	30
38434	28	38532	Call	39084	27	4131D-M	10	5135-ROLL	43	6050E	3	6132Z	6	6437	30
38435	28	38533	Call	39084-P	27	4131-M	10	5221	43	6050KD	5	6133Z	6	6454	9
38436	28	38534	Call	39090	27	4158E	4	5221-S	43	6050-P	1	6134Z	6	6454D-M	10
38437	28	38535	Call	39090-P	27	4158KD	5	5258	42	6056E	3	6135Z	6	6454-M	10
38440	28	38536	Call	39091	27	4158-P	2	5366	44	6056-P	1	6136Z	6	6628	22
38441	28	38537	Call	39091-P	27	4205E	3	5379	18	6057E	3	6137Z	6	6628T	22
38442	28	38540	Call	39092	27	4205-P	1	5379-SS	18	6057-P	1	6138Z	6	6715	22
38443	28	38541	Call	39092-P	27	4215	11	5381	22	6058E	3	6139Z	6	6733	44
38444	28	38542	Call	39093	27	4333	44	5383	24	6058-P	1	6140Z	6	6755	15, 43
38445	28	38543	Call	39093-P	27	4349	31	5385	24	6059E	3	6141	8	6756	15, 43
38446	28	38544	Call	39094	27	4354	44	5514-FLR	44	6059-P	1	6142	8	6757	15, 43
38447	28	38545	Call	39094-P	27	4570E	4	5522-FLR	44	6060E	3	6143	8	6758	15, 43
38450	28	38546	Call	39095	27	4570KD	5	5523-FLR	44	6060-P	1	6144	8	6763	43
38451	28	38547	Call	39096	27	4570-P	2	5641	44	6061E	3	6145	8	6767	26, 43
38452	28	38550	Call	39097	27	4609E	4	5710-3	41	6061-P	1	6146	8	6767-2000	43
38453	28	38551	Call	39098	27	4609-P	2	5710-4	41	6062E	3	6147	8	6771	43
38454	28	38552	Call	39099	27	4610E	3	5711-3	41	6062-P	1	6148	8	6777	43
38455	28	38553	Call	39100	27	4610KD	5	5711-4	41	6063E	3	6149	8	6791	9
38456	28	38554	Call	39110	27	4610-P	1	5712	41	6063-P	1	6150	8	6791D-M	10
38457	28	38555	Call	4000E	3	4611E	4	5713	41	6064E	3	6151	8	6791-M	10
38460	27	38556	Call	4000KD	5	4611-P	2	5714	41	6064-P	1	6152	8	6847	45
38461	27	38557	Call	4000-P	1	4612E	3	6001Z	6	6065E	3	6153	8	6851	45
38462	27	38560	Call	4051	30	4612-P	1	6002Z	6	6065-P	1	6154	8	6851-HE	45
38464	27	38561	Call	4052	30	4613E	3	6003Z	6	6076	9	6155	8	6851-SS	45
38465	27	38562	Call	4053	30	4613KD	5	6004Z	6	6077	9	6156	8	6874	43
38466	27	38563	Call	4054	30	4613-P	1	6005Z	6	6078	9	6157	8	6950	9
38467	27	38564	Call	4055	30	4614E	4	6006Z	6	6079	9	6158	8	6950D-M	10
38468	27	38565	Call	4056	30	4614KD	5	6007Z	6	6080	9	6159	8	6950-M	10
38470	29	38566	Call	4057	30	4614-P	2	6008Z	6	6081	9	6160	8	6974	44
38471	29	38567	Call	4058	30	4615E	3	6009Z	6	6082	9	6195	11	7024	44
38472	29	38568	Call	4060	30	4615-P	1	6010Z	6	6083	9	6195-UNI	11	7029	33
38473	29	38569	Call	4061	30	4616E	4	6021Z	6	6084	9	6283	45	7030	33
38474	29	38570	18	4062	30	4616-P	2	6022Z	6	6085	9	6283-RB	45	7031	33
38475	29	38570-SS	18	4063	30	4617E	3	6023Z	6	6096	9	6283-RULON	45	7032	33
38480	29	38571	18	4064	30	4617KD	5	6024Z	6	6096D-M	10	6329	43	7032-U	33
38481	29	38571-SS	18	4065	30	4617-P	1	6025Z	6	6096-M	10	6330	43	7033	33
38482	29	38580	19	4066	30	4618E	4	6026Z	6	6097	9	6335	43	7033-U	33
38483	29	38581	19	4067	30	4618KD	5	6027Z	6	6097D-M	10	6335-BRN	43	7034	33
38484	29	38582	19	4070	30	4618-P	2	6028Z	6	6097-M	10	6343Z	7	7034-U	33
38485	29	38583	22	4071	30	4619E	3	6029Z	6	6098	9	6408	30	7035	33
38486	29	38584	22	4072	30	4619-P	1	6030Z	6	6098D-M	10	6409	30	7035-U	33
38487	29	39000	21	4073	30	4620E	4	6041E	3	6098-M	10	6410	30	7036	33
38488	29	39001	21	4074	30	4620-P	2	6041KD	5	6099	9	6411	30	7036-U	33
38488-D	29	39002	21	4075	30	4621E	3	6041-P	1	6099D-M	10	6412	30	7037	33
38489	29	39003	21	4076	30	4621KD	5	6042E	3	6099-M	10	6413	30	7037-U	33
38490	29	39030	27	4077	30	4621-P	1	6042KD	5	6100	9	6414	30	7038	33
38491	29	39031	27	4079	30	4622E	4	6042-P	1	6100D-M	10	6415	30	7038-U	33
38492	29	39032	27	4080	30	4622KD	5	6043E	3	6100-M	10	6416	30	7039	33
38493	29	39033	27	4081	30	4622-P	2	6043KD	5	6101	9	6417	30	7039-U	33
38494	29	39034	27	4082	30	4623E	3	6043-P	1	6101D-M	10	6418	30	7124	12
38495	29	39060	27	4083	30	4623-P	1	6044E	3	6101-M	10	6419	30	7124-4	12
38496	29	39061	27	4084	30	4624E	4	6044KD	5	6102	9	6420	30	7127	12
38510	29	39062	27	4085	30	4624-P	2	6044-P	1	6102D-M	10	6421	30	7127-4	12
38511	29	39063	27	4086	30	4626	45	6045E	3	6102-M	10	6422	30	7176	32
38512	29	39064	27	4087	30	5000	41	6045KD	5	6103	9	6423	30	7176-U	32
38513	29	39070	27	4088	30	5000-1	41	6045-P	1	6103D-M	10	6424	30	7177	32
38514	29	39071	27	4089	30	5000-2	41	6046E	3	6103-M	10	6425	30	7177-U	32
38515	29	39072	27	4090	30	5000-3	41	6046KD	5	6121Z	6	6426	30	7178	32
38516	29	39073	27	4091	30	5024	43	6046-P	1	6122Z	6	6427	30	7178-U	32
38517	29	39074	27	4092	30	5027-PL	26	6047E	3	6123Z	6	6428	30	7179	32
38518	29	39080	27	4093	30	5054	42	6047KD	5	6124Z	6	6429	30	7179-U	32



INDEX BY ITEM NUMBER

ITEM #	PAGE	ITEM #	PAGE	ITEM #	PAGE	ITEM #	PAGE	ITEM #	PAGE	ITEM #	PAGE	ITEM #	PAGE
7180	32	7487	9	7729-S	22	8207	32	8247	34	9026-1	14	RDGS-244812	23
7180-U	32	7488	9	7737-ROLL	43	8207-U	32	8247-U	34	9026-19	14	RDGS-246012	23
7181	32	7489	9	7780	43	8208	32	8248	34	9026-9	14	RDTA-184808	23
7181-U	32	7489D-M	10	7793	42	8208-U	32	8248-U	34	9269	44	RDTA-203608	23
7182	32	7489-M	10	7836	42	8209	32	8249	34	9358	44	RDTA-203612	23
7183	32	7490	9	7942	11	8209-U	32	8249-U	34	9336-46LT2	13	RDTA-204808	23
7184	32	7490D-M	10	7942-12	11	8210	32	8250	34	9375	45	RDTA-204812	23
7217	43	7490-M	10	7973-(LR)	44	8210-U	32	8250-U	34	9375-BR	45	RDTA-206008	23
7270	42	7491	9	80001	42	8211	33	8251	34	9380	17	RDTA-206012	23
7322E	4	7491D-M	10	80002	42	8212	33	8251-U	34	9381	17	RDTA-243608	23
7322-P	2	7491-M	10	80032	42	8213	33	8252	34	9382	17	RDTA-243612	23
7323E	4	7492	9	80033	42	8214	33	8252-U	34	9383	17	RDTA-244808	23
7323-P	2	7492D-M	10	8039	42	8214-U	33	8253	34	9384	17	RDTA-244812	23
7324E	4	7492-M	10	8074	43	8215	33	8253-U	34	9385	17	RDTA-246008	23
7324-P	2	7493	9	8090	43	8215-U	33	8254	34	9388	17	RDTA-246012	23
7325E	4	7493D-M	10	8167	32	8216	33	8254-U	34	9433	45	RDTs-184808	23
7325-P	2	7493-M	10	8167-U	32	8216-U	33	8255	34	9434	45	RDTs-203608	23
7326E	4	7494	9	8168	32	8217	33	8256	34	9508	11	RDTs-203612	23
7326-P	2	7495	9	8168-U	32	8217-U	33	8257	34	9508-1	11	RDTs-204808	23
7327E	4	7496	9	8169	32	8218	33	8258	34	9677	43	RDTs-204812	23
7327-P	2	7497	9	8170	32	8218-U	33	8258-U	34	9689	18, 42	RDTs-206008	23
7328E	4	7498	9	8180	32	8219	33	8259	34	9689-WH	18, 42	RDTs-206012	23
7328-P	2	7499	8	8181	32	8219-U	33	8259-U	34	9690	18, 42	RDTs-243608	23
7329E	4	7500	8	8181-U	32	8220	33	8260	34	9690-WH	18, 42	RDTs-243612	23
7329-P	2	7501	8	8182	32	8220-U	33	8260-U	34	9784	13	RDTs-244808	23
7330E	4	7502	8	8182-U	32	8221	33	8261	34	9933	45	RDTs-244812	23
7330-P	2	7503	8	8183	32	8221-U	33	8261-U	34	BA-60	25	RDTs-246008	23
7331E	4	7504	8	8183-U	32	8222	33	8262	34	BA-80	25	RDTs-246012	23
7331-P	2	7505	8	8184	32	8223	33	8262-U	34	DB-80	25	TPS3048	27
7332E	4	7506	8	8184-U	32	8224	33	8263	34	DB-140	25	TPS3060	27
7332KD	5	7507	8	8185	32	8225	33	8263-U	34	DL-80	25	TPS3072	27
7332-P	2	7508	8	8185-U	32	8225-U	33	8264	34	DL-80E	25	TPS3084	27
7333E	4	7509	8	8186	32	8226	33	8264-U	34	DL-140	25	TPS3096	27
7333KD	5	7510	8	8186-U	32	8226-U	33	8265	34	UT-140	25	TPS3648	27
7333-P	2	7511	8	8187	32	8227	33	8265-U	34	RDCA-203608	23	TPS3660	27
7334E	4	7512	8	8187-U	32	8227-U	33	8266Z	7	RDCA-203612	23	TPS3672	27
7334KD	5	7513	8	8188	32	8228	33	8267Z	7	RDCA-204808	23	TPS3684	27
7334-P	2	7514	8	8188-U	32	8228-U	33	8268Z	7	RDCA-204812	23	TPS3696	27
7335E	4	7515	8	8189	32	8229	33	8269Z	7	RDCA-206008	23	TSS3048	27
7335KD	5	7516	8	8190	32	8229-U	33	8270Z	7	RDCA-206012	23	TSS3060	27
7335-P	2	7517Z	7	8191	32	8230	33	8271Z	7	RDCA-243608	23	TSS3072	27
7336E	4	7518Z	7	8192	32	8230-U	33	8272Z	7	RDCA-243612	23	TSS3084	27
7336KD	5	7519Z	7	8192-U	32	8231	33	8273Z	7	RDCA-244808	23	TSS3096	27
7336-P	2	7520Z	7	8193	32	8231-U	33	8274Z	7	RDCA-244812	23	TSS3648	27
7337E	4	7521Z	7	8193-U	32	8232	33	8275Z	7	RDCA-246008	23	TSS3660	27
7337KD	5	7522Z	7	8194	32	8232-U	33	8276Z	7	RDCA-246012	23	TSS3672	27
7337-P	2	7523Z	7	8194-U	32	8233	33	8277Z	7	RDCS-203608	23	TSS3684	27
7338E	4	7524Z	7	8195	32	8234	33	8278Z	7	RDCS-203612	23	TSS3696	27
7338KD	5	7525Z	7	8195-U	32	8235	33	8279Z	7	RDCS-204808	23	TWS3048	27
7338-P	2	7526Z	7	8196	32	8236	33	8280Z	7	RDCS-204812	23	TWS3060	27
7339E	4	7527Z	7	8196-U	32	8236-U	33	8281Z	7	RDCS-206008	23	TWS3072	27
7339KD	5	7528Z	7	8197	32	8237	33	8282Z	7	RDCS-206012	23	TWS3084	27
7339-P	2	7529Z	7	8197-U	32	8237-U	33	8283Z	7	RDCS-243608	23	TWS3096	27
7340E	4	7530Z	7	8198	32	8238	33	8284Z	7	RDCS-243612	23	TWS3648	27
7340KD	5	7531Z	7	8198-U	32	8238-U	33	8285Z	7	RDCS-244808	23	TWS3660	27
7340-P	2	7532Z	7	8199	32	8239	33	8366	21	RDCS-244812	23	TWS3672	27
7341E	4	7533Z	7	8199-U	32	8239-U	33	8417-PL	26	RDCS-246008	23	TWS3684	27
7341KD	5	7534Z	7	8200	32	8240	33	8428	42	RDCS-246012	23	TWS3696	27
7341-P	2	7535Z	7	8201	32	8240-U	33	8467	43	RDGA-203612	23		
7354	30	7632-18	25	8202	32	8241	33	8495	15, 43	RDGA-204812	23		
7355	30	7632-20	25	8203	32	8241-U	33	8546-LT	42	RDGA-206012	23		
7364	43	7632-22	25	8203-U	32	8242	33	8617	43	RDGA-243612	23		
7409-TS	25, 45	7632-MODI-60	25	8204	32	8242-U	33	8796	11	RDGA-244812	23		
7411	43	7632-MODI-80	25	8204-U	32	8243	33	9021	45	RDGA-246012	23		
7412	43	7632-MODI-140	25	8205	32	8243-U	33	9021-5	45	RDGS-203612	23		
7484	9	7674	43	8205-U	32	8244	34	9021-HT	45	RDGS-204812	23		
7485	9	7706-Roll	43	8206	32	8245	34	9021-LT	45	RDGS-206012	23		
7486	9	7729	22	8206-U	32	8246	34	9026	14	RDGS-243612	23		

Index by Item Number



RACK ORDER FORM

Rack Order Form

OVEN RACKS

Item # Qty.

Bakers Aid Style - Standard & Nesting Racks

Bottom Locator - Aluminum & Stainless Steel - Single & Double - End & Side Load.....		
Pin Guide - Aluminum & Stainless Steel - Single & Double - End & Side Load.....		
Top Lift - Aluminum & Stainless Steel - Single & Double - End & Side Load.....		

Baxter Style - Standard & Nesting Racks

Model Adv1 - Aluminum & Stainless Steel - Single - End & Side Load.....		
Model Adv2 - Aluminum & Stainless Steel - Single & Double - End & Side Load.....		

Dahlen/Gemini Style - Standard & Nesting Racks

Model 1000 - Aluminum & Stainless - Single - End Load - 65"H.....		
Model 2000 - Aluminum & Stainless - Single - End & Side Load - 74"H.....		
Model 4000 - Aluminum & Stainless - Double - Side Load - 74"H.....		
Model 9100-02 - Roller Coupler - Aluminum & Stainless - Single - End Load - 72"H.....		
Model 9040-42 - Roller Coupler - Aluminum & Stainless - Steel Double - Side Load - 72"H.....		
Model 9100-02 - Channel Coupler - Aluminum & Stainless - Single - End Load - 72"H.....		
Model 9040-42 - Channel Coupler - Aluminum & Stainless Steel - Double - Side Load - 72"H.....		
Model 9060-62 - No Coupler - Aluminum & Stainless Steel - Double - Side Load - 70.94"H.....		

Cut here

Lucks Style - Standard & Nesting Racks

Model R10 & R20 - Aluminum & Stainless Steel - Single & Double - End & Side Load.....		
---	--	--

Miwe Style - Standard & Nesting Racks

Bottom Locator - Aluminum & Stainless Steel - Single & Double - End & Side Load.....		
Top Lift - Aluminum & Stainless Steel - Single & Double - End & Side Load.....		

Revent & Hobart Style - Standard & Nesting Racks

"A" Style Coupler - Aluminum & Stainless Steel - Single Double - End & Side Load.....		
"B" Style Coupler - Aluminum & Stainless Steel - Single Double - End & Side Load.....		
"C" Style Coupler - Aluminum & Stainless Steel - Single Double - End & Side Load.....		
"D" Style Coupler - Aluminum & Stainless Steel - Single Double - End & Side Load.....		
Heavy Duty - Aluminum - Single - End & Side Load.....		

PAN RACKS/CARTS

Bun Pan Racks

Heavy Duty - Aluminum & Stainless Steel - End Load.....		
Heavy Duty - Aluminum & Stainless Steel - Side Load.....		
Standard Duty - Aluminum & Stainless Steel - End Load.....		
Standard Duty - Aluminum & Stainless Steel - Side Load.....		
Super Heavy Duty - Aluminum - End & Side Load.....		
Industrial - Magnum Series - Aluminum & Stainless Steel - Single or Double.....		

Cabinets/Enclosed Racks

Heavy Duty - Aluminum - 1/2 Size.....		
Heavy Duty - Aluminum - 3/4 Size.....		
Heavy Duty - Aluminum - Full Size.....		

Cut here

Can Storage Racks.....

Channel Frame Racks.....

Channel Slide Racks.....

Cooling Racks.....

Display/Slanted Shelves Racks.....

DOLLIES & TRUCKS

Bread Pan Dollies.....		
Chicken Pan Dollies.....		

DONUT RACKS/ACCESSORIES.....

DUNNAGE RACKS.....

Mobile Dunnage Racks.....		
Stationary Dunnage Racks.....		

HALF SIZE/UNDER COUNTER RACKS.....

KNOCK DOWN RACKS.....

LUG CARTS.....

MOBILE RACKS/WORK-TOP

Poly Top - Aluminum or Stainless Steel Top.....		
Poly Top - Aluminum or Stainless Steel Top / Open Section.....		

TRAY DRYING RACKS.....

NESTING RACKS.....

PIZZA PAN RACKS.....

PLATTER CARTS.....

POLY BOX RACKS.....

SHEET PAN TRUCKS.....

TRANSPORTATION RACKS.....

UTILITY - FOOD SERVICE CARTS.....		
-----------------------------------	--	--

Cut here



TERMS AND CONDITIONS OF SALE



■ ■ ■ ■ ■ ■ ■ ■

MAGNA INDUSTRIES INC., Terms and Conditions of Sale. Product(s) have been sold to the Buyer on these Terms and Conditions of Sale.

Acceptance: Buyer's action in acceptance of all of the Terms and Conditions set forth by Magna Industries Inc., hereafter referred to as Magna. If any of the Buyer's terms are in conflict with these Terms and Conditions of Sale, the terms of Magna shall govern, unless buyer's terms are accepted in writing by Magna. No verbal agreement or understanding shall in any way modify the Terms and Conditions of sale.

DELIVERY: Unless otherwise specified in writing by Magna, all prices are F.O.B. manufacturer's warehouse. Transportation will be by method, route and carrier selected by Magna. All freight charges will be responsibility of the buyer. Magna cannot assume responsibility for collecting any taxes other than New Jersey State tax. Buyer shall bear (or shall reimburse Magna) for all taxes and/or excises or other government charges or levies. Magna shall not be liable for delay in or failure of delivery where delivery has been made impossible or impractical by the occurrence of a contingency such as war, intervening government regulations, civil commotion, riot, disorder, strike or other labor stoppage or difficulty, fire, flood, storm, accident, production failure, raw material shortage, transportation failure or act of God. In any event, Magna may, at its sole discretion allocate products among buyers. Magna's count of goods shipped shall govern except in case of proven error.

DAMAGED MERCHANDISE: Our responsibility for shipment ceases with acceptance by carriers. If any goods called for on the Bill of Lading are short or damaged, do not accept them until the freight agent makes a damage notation on your freight bill. Thoroughly inspect the shipment as soon as received - if any concealed loss or damage is discovered, notify freight agent at once and request an inspection. This is absolutely necessary. Unless you do this, the transportation company will not entertain any claim for loss or damage. If agent will not make an inspection, then you should make an affidavit that you notified him (on a certain date) and he failed to do so. This, with other shipping papers, will properly support your claim.

CLAIMS PROCEDURES: In no event shall Magna be liable on any claim unless written notice of the claim, sent certified mail, return receipt requested, is received by Magna within thirty (30) days after delivery. Failure of Buyer to assert claim within such time shall be deemed a waiver by the buyer of all claims with respect to such products. Buyer shall have the right to reject non-conforming products or to make claim for monetary adjustment, or at Magna's option, to return non-conforming goods and disputed products to Magna but, (1) in no event shall any claim of any kind be greater than the purchase price of the product in respect of which damages are claimed, and (2) in no event may any product be returned to Magna without Magna's prior written consent. Buyer shall afford Magna prompt and reasonable opportunity to inspect all material as to which any claim is made. No claim shall be allowed after the product has been processed in any manner.

PAYMENTS: Terms are 50% deposit with order balance prior to or on delivery unless previous credit terms are arranged. Interest shall be charged at the rate of 1.75% per month, or maximum allowed by law, whichever is greater, from the due date on all past due accounts. If, in the judgment of Magna, the financial credit of the Buyer at any time does not justify continuance of production or shipment of the product based on payment terms herein specified, Magna may require full or partial payment prior to completion or shipment.

INDEMNITY: In addition to each and every item and condition herein which refers to some type of indemnity requirement of Buyer in favor of Magna, Buyer shall exculpate, defend indemnify and hold harmless Magna for all losses, damages or liabilities resulting. Magna warrants to the original purchaser that its equipment will be free from defects in the material and/or workmanship for the period of one (1) year from the date of original invoice, provided the equipment is reported installed on a registration card and returned to Magna. The purchaser is responsible for, having the equipment properly installed, operated under normal conditions with proper supervision and the performance of periodic preventive maintenance. Magna's obligation under this warranty shall be replacement or repair of defective parts within the warranty period. After thorough examination, the decision of Magna's service department shall be final. Any defective parts to be repaired or replaced must be returned to Magna within thirty (30) days of installation of the replacement part, transportation charges are to be prepaid, and the parts must be properly packaged and tagged. The serial number and model number of the equipment, and the date of original installation must be given. We will not however, assume any responsibility for any expenses (including labor) incurred in the field incidental to the repair or replacement of equipment covered by this warranty. Our obligation thereunder to repair or replace a defective part is the exclusive remedy for breach of this warranty; and we will not be liable for any damages or claims, including consequential damages. No representative, dealer, distributor or any person is authorized or permitted to make any other warranty or obligate Magna to any liability not strictly in accordance with this policy. All equipment manufactured by others, but included as part of this contract, will be subject to standard warranty as issued by the original manufacturer thereof and is not warranted by Seller.

PAST DUE ACCOUNTS: May be subject to a service charge of 1.75% per month (21% annual).

COLLECTION COSTS: Customer will be liable for any collection costs including reasonable attorney's fees and court fees.

WAIVER: Waiver by Magna or Buyer of a breach of any condition shall not be construed as waiver of that or any other condition.

GOVERNING LAW: The purchaser shall be construed in accordance with and governed for all purposes by the laws and public policy of the State of New Jersey, where Magna is incorporated, applicable to contracts executed and to be performed wholly within such state.

ENTIRE AGREEMENT: Magna's invoice contains the entire agreement of the parties with respect to the purchaser covered by the Terms and Conditions and supersedes all prior agreements and understandings between the parties with respect of such purchase; and may not be amended, supplemented, canceled or discharged without prior written notice sent certified, return receipt requested, by party affected.

TITLE AND RIGHT OF POSSESSION: The title and right of possession of the product specified shall remain with Magna until all payments have been fully made in cash to Magna at its office in Lakewood, New Jersey. It is understood and agreed that the above product shall remain in Magna's personal property whatever the mode of its attachment is to realty or otherwise fully paid for in cash. An express Material -man's and Mechanic's lien hereby conveyed and granted to Magna upon the building of real property in which the above described personal property is to be erected for the purpose of any one remedy by Magna shall not be to the exclusion of any other remedy, but all rights and remedies of Magna are expressly retained, and are cumulative of each other.

In the event Magna is compelled to bring action in court against Buyer to enforce any of the provisions of this agreement, Buyer agrees to pay Magna's reasonable and customary attorney fees and court costs in addition to all other sums due to Magna.

CHANGES OR CANCELLATIONS: Changes or cancellations without liability of this proposal after acceptance by the Buyer can be made only with Magna's agreement in writing. In the event of cancellation or suspension of manufacture of product at the buyer's request the Buyer agrees as a cancellation charge to reimburse Magna promptly for all expenditures for materials used or appropriated, labor and engineering service, a proportionate share of indirect manufacturing, engineering, selling and general and administration expenses incurred in connection with such manufacture so far as it has been completed, and contemplated normal profit on this proposal in accordance with invoice to be rendered by Magna. In the event of change of specifications at the Buyer's request, the Buyer agrees to reimburse Magna for all services, labor or material discarded because of such changes. In addition, the Buyer also agrees to reimburse Magna for extraordinary costs and other expenses attributable to such changes, suspension or cancellation.

RESTOCKING CHARGES: Upon cancellation of an order, after shipment, before uncrating, Buyer is liable for a restocking fee of not more than twenty-five percent (25%) provided: (i) written permission to return product is obtained; (ii) equipment is returned to the warehouse within thirty (30) days from date of shipment; (iii) initial delivery and return transportation charges have been paid by Buyer in full.

ASSIGNMENT: Neither Magna or Buyer have the right or interest in Magna's quotation or any resulting contract unless such an agreement in connection with the transfer of all or substantially of the assignor's business.

OWNERSHIP: The specifications, drawings, manufacturing data and other information transmitted between Magna and Buyer in connection with Magna's quotation and any resulting sale are property of the original party, and are disclosed in confidence on the condition that they are not to be reproduced, copied or used for any purpose detrimental to the interest of the other.

SPECIAL ORDERS: All equipment manufactured upon Buyer's written order shall be invoiced at the time of the equipment's arrival at Magna's warehouse. Special orders are not subject to cancellation.

Terms and Conditions of Sale



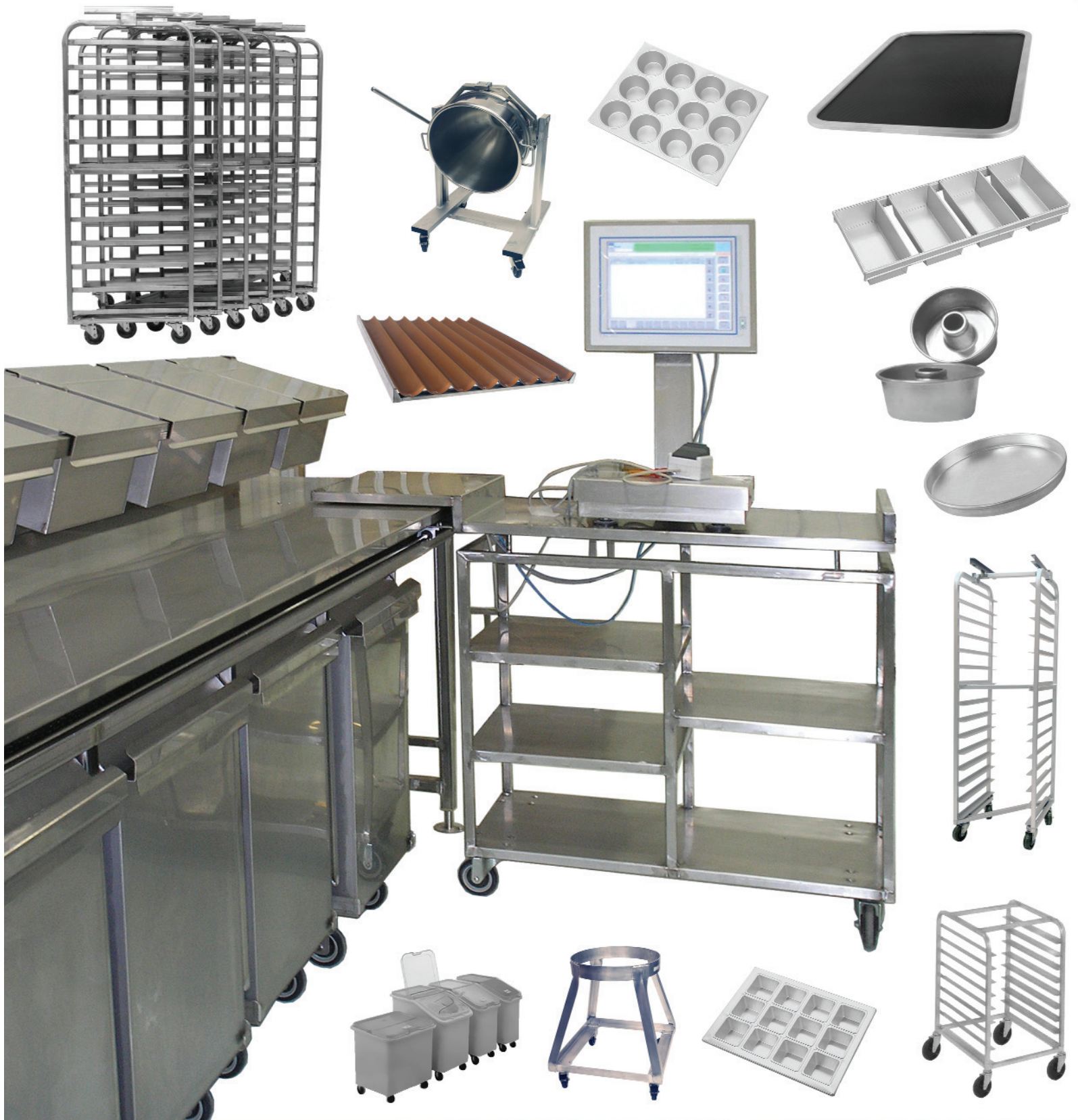

Magna Industries

1825 Swarthmore Avenue, Lakewood, NJ 08701

Toll Free 1.800.510.9856 Office 732.905.0957 Fax 732.367.2989

www.magnaindustries.com sales@magnaindustries.com