



CATALOGUE

2017





Dear Bakers

We are celebrating 70 years of JAC.

Above all, we owe this longevity to you. In fact, it is thanks to the encouragement and loyalty of so many of you around the world that, over the years, we have become a force in the bakery sector.

What a road we have travelled since the days of the first slicing machines in a 100 sq. m. workshop.

At this stage in our history, we are able to offer you a complete range of machines, both in the slicing sector and in dough processing.

Every product has come into being by us listening to what you want and then through the imagination and perseverance of our engineers.

Our objective every day is to be at the forefront of technology and improve the performance of our machines.

I am confident that the developments and innovations that you will discover in these pages will surprise and delight you.

With my sincerest thanks for the trust you show in our products,

A handwritten signature in cursive script, enclosed in a thin white rectangular border. The signature appears to read 'Raulo La Courtois'.

Chairman of JAC



Pain complet 100%  
110 8000 1.10

Pain complet 100%  
110 8000 1.10

Boule  
de pain  
et levain  
d'épave  
VTK 7.50

Pain  
Rouge  
1.50  
2.50

Pain  
craquelé  
VTK

Pain  
craquelé  
1.10

6 At your service

8 Our expertise

## Bread slicers



12 Semi-automatic slicers



18 Automatic slicers



24 Automatic circular blade slicer



28 Self-service slicer



32 Self-service circular blade slicer



36 Bun & bagel slicer



40 Continuous cut slicers

## Dough processing



**46** Sourdough fermentors

**50** Hydraulic dividers

**54** Divider-moulders

**60** Divider-moulder accessories

**64** Volumetric dividers

**68** Proofer

**72** Moulders

**76** Moulder accessories

# At your service...



## R&D

JAC's research and development team is split into two sectors: bread slicing and dough processing. Located at both manufacturing facilities and seamlessly linked to the other departments.

R&D's goal is to constantly innovate and develop market leading products which respond to customer requirements and ever-evolving market needs.



## Sales

Interactive and multi-cultural, two qualities that define our sales team. Wherever you are it is our goal to be by your side and to understand, support and respond efficiently to your requirements. We want to be your partner.



## After sales service

Responsiveness and Proficiency. JAC after-sales and spare parts departments guarantee responsiveness, proficiency and speed of delivery. Pillars that are the base of the JAC after-sales organization. Our team of technicians is always available to provide on-going support and training.

# wherever you are!



«I was won over as soon as I bought my first JAC machine and I have never changed my mind over the years.»

Today I have a JAC slicer in all of my branches.»

**Hans-Peter Saur**  
«Bäcker Saur»  
Horb am Neckar, Deutschland



«As we develop our company, we place the emphasis on selling sourdough bread made with traditional yeast and the Tradilevain. It is also a priority for us to kit out all our stores with the right slicer; this is why we have been working with Jac for many years.»

**Wojtek Skalbani**  
«Piekarnia Rustykalna»  
Radom, Poland



«Bread is life! When you produce it correctly, you respect it! JAC means productivity in complete simplicity.»

**Christophe Zunic**  
«Le four à bois»  
Reims, France

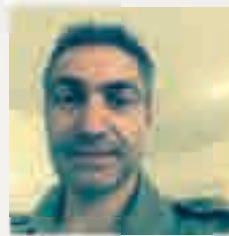

«Our JAC has had exceptional performance and reliability levels; it is an important part of our production requirements and was a vital investment for our company.»

**Sab Spiniello**  
«Paesano Bakery»  
Kensington Park, Australia



«My JAC Tradilevain is at the heart of everything I produce. I am also a huge fan of the Tradiform method, which lets me do practically everything.»

**Vincent Foré**  
«Bculangerie Van Cauwenberghe»  
Destelbergen, Belgium



«The FORMA has made it possible to improve product quality and optimize forming all at once. The DIV 10/20 option presents a practical advantage as it enables dough pieces over 1 kg. And with our DURO we achieve perfect slicing free of excess crumb or tearing issues.»

**Ilya Pavlov**  
«Lenta»  
St Pétersbourg, Russia

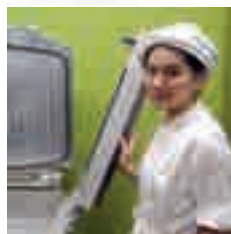

«Get fresh bread every morning with this stable and effective JAC machine.»

**Jia-Ling, Wu**  
«Feco Corporation»  
Taipei City, Taiwan



«JAC Equipment has helped us broaden our product range.»

**Alan Crosley**  
«Empire Bake»  
New York, United States

# Bread slicers

## Semi-automatic frame slicers

PICO



DURO



## Automatic frame slicers

PICOMATIC



ECO+



## Automatic circular blade slicer

VARIA PRO



SLIM PRO



## Our expertise

### Efficiency

The Intelligent Slicing Concept (ISC) is a (patented) continuous automatic management system which adapts the cutting action according to the consistency of the bread.

This patented system slices all types of bread without operator input, whether open textured, crusty or dense, with no need to worry about adjusting the slicer. Just like you, the JAC ISC slicer has real know-how.

### Function

All our circular blade slicers are fitted with an automatic claw, because, at JAC, comfort takes precedence over technical considerations.

Position the loaf, close the cover; the claw locks the loaf in place automatically.

### Sanitation

Our crumb collector is perfectly positioned and easily accessible behind the front door. With its ergonomic position and large capacity it is a perfect example of the care we always take to maintain sanitation, comfort and performance.





### Self-service frame slicer

*NEW SELF*



### Self-service circular blade slicer

*VARIA SELF*



### Bun & Bagel slicer

*ZIP*



### Continuous cut slicers

*CHUTE*



*CHUTE+*



*FULL*



## Ergonomics

Ergonomics research has led JAC's engineers to design a force inverter linked to the slicing lever. This device allows you to save on effort during the day, while always ensuring quick, efficient slicing.

The action produced by this progressive traction lever also starts the cut carefully and maintains pressure when the sliced bread is removed.



## Safety

The latest safety standards require a rear cover which prevents access to the slicing area during the automatic cutting cycle.

JAC has gone further with a cover linked to the start mechanism and automatic opening.

Insert the bread, close the cover and the slicing cycle is activated. Once the bread is sliced, the cover opens automatically and the machine is ready for another loaf. The best in ergonomics and safety!



## Colors

Choice possible between different standard colours on a few models (see your dealer/ to be discussed with your dealer).



RAL 1015



RAL 3013



RAL 9005

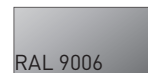

RAL 9006

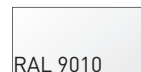

RAL 9010



# Dough processing

## Sourdough fermentors

*TRADILEVAIN*



## Hydraulic dividers

*DIV*

*DIV-R*



## Divider-moulders

*TRADIFORM*

*EASYFORM*



## Volumetric dividers

*CDS*



## Our expertise

### Comfort

JAC DIV-R and Tradiform dividers are supplied with a (patented) anti-splatter system. Using a seal in the cover inhibits flour from being released into your bakery during the dividing cycle. The flour is channeled into an enclosure on the front of the divider.



### Hygiene

To ensure our JAC range of equipment comes with the highest level of sanitation, we supply our moulders, dividers and divider-moulders with stainless steel exteriors.



### Ease of use

Sticky doughs can cause serious cleaning issues. JAC treats the bottom of our tanks with easy-clean technology. A molecular process based on silver particles that provide unequalled non-stick and anti bacterial protection.



## Proofers

*MB*



## Moulders

*LINE*



## Economy

Noise levels are important. JAC dividers utilize hydraulic units which operate at under (-65dB) and only operate when the lever is pulled.

### START & STOP







## Complete range

Table-top or on casters, 18" or 24" cutting width, single or double slicing... The JAC range of slicers is designed to meet your needs. With a traditional look and uncluttered design and in a choice of colours, they will fit perfectly into your bakery.

## Affordable

Very competitive pricing with superior quality is the JAC standard. Features such as robust frames, progressive traction lever, locking casters, reinforced blades, automatic lever-action stopping and starting and ergonomic crumb trays are supplied as standard.

## Robust

Regular maintenance ensures that your slicer will last a long time. Slicing bread exactly the way you want it for many years.



# Semi-automatic frame slicer

# PICO

- ✓ Minimum space requirement
- ✓ Can be used on a counter-top or on a base.
- ✓ Progressive traction lever
- ✓ Front-loading for ergonomic efficiency
- ✓ 5 years parts / 1 year labor warranty

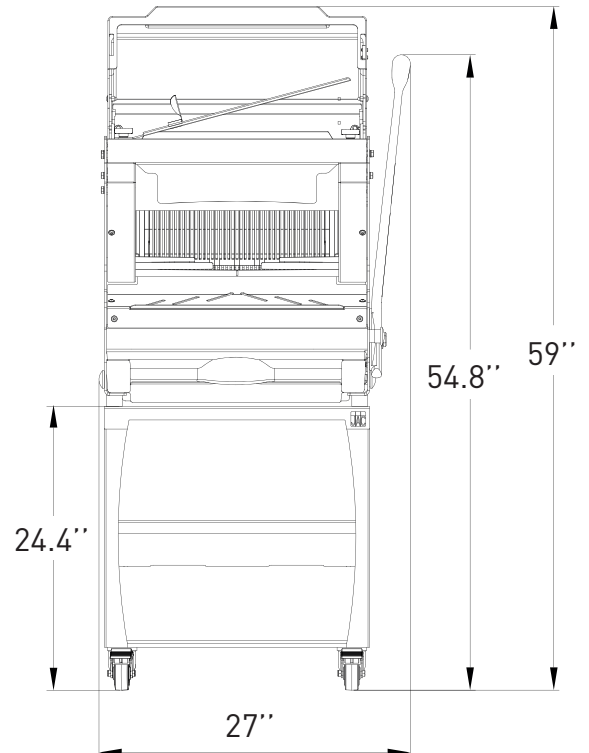
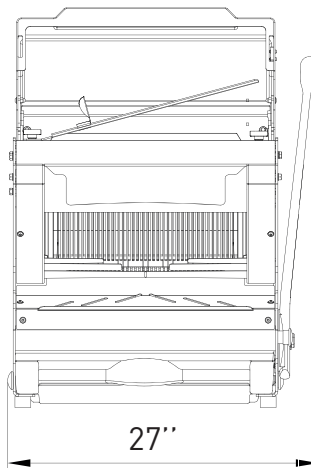
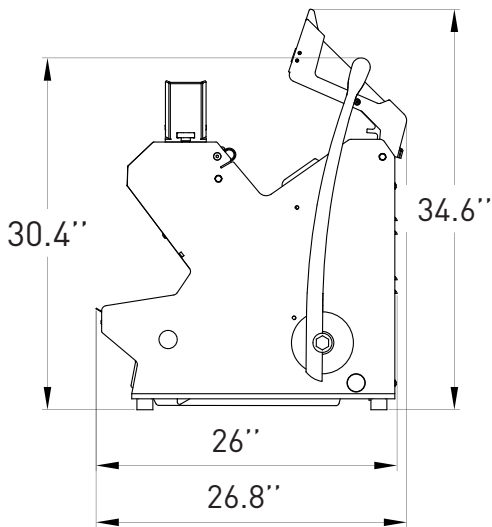

Traditionally Innovative

[www.jac-machines.com](http://www.jac-machines.com)

[office@jac-machines.com](mailto:office@jac-machines.com)



**Progressive traction lever**  
Provides better control .



**Removable crumb collector**  
Made of light-weight material, accessible from the front. 1,85 gallons capacity.



**JAC FLAPS**  
Holds the loaf together for easier handling.



**Rear safety cover**  
Lever actuated, closes the cover starts the slicing cycle



**Front safety cover**  
If opened during the slicing cycle, the machine stops.



**Stand with castors**  
Provides storage space and mobility.

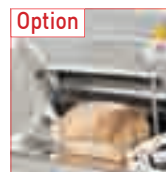

**Jacfix**  
Slices holding system.

**PICO 450**

**FEATURES**

Max. loaf dimensions in in (L x W x H) without cover	17.3" x 11.8 x 7"
Max. loaf dimensions in in (L x W x H) with cover	17.3" x 11.8" x 6.3"
Motor power in kW	0.49
Type of motor	1ph/120V/60Hz/7.3A
Net weight in lbs	231.5

**CHOICES**

Slice thickness options	from 3/8th to 1 1/4"
-------------------------	----------------------

**OPTIONS**

Stand with castors	•
Rear safety cover	•
Front and rear safety covers	•
<b>Jacfix</b>	•



# DURO

## Semi-automatic frame slicer

- ✓ Robust
- ✓ Progressive traction lever
- ✓ Available as single or dual slice models
- ✓ 5 years parts / 1 year labor warranty

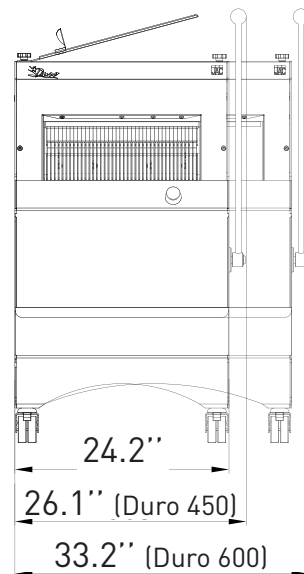
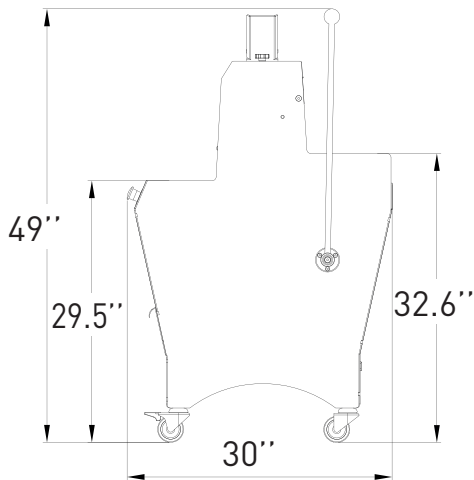

Traditionally Innovative

[www.jac-machines.com](http://www.jac-machines.com)

[office@jac-machines.com](mailto:office@jac-machines.com)





**Progressive traction lever**  
Provides better control.



**Option**  
**Double slice thickness**  
Allows two different slice thicknesses on the same machine.



**Removable crumb collector**  
Accessible from the front, collects up to 4 gallons of crumbs.



**Option**  
**Stainless steel rear safety cover**  
Lever actuated, closes the cover starts the slicing cycle



**Bagging spade**  
For easy bagging of sliced loaves.



**Option**  
**1.6" height adjustment**  
Increases working comfort for tall operators.

## FEATURES

	<b>DURO 450</b>	<b>DURO 600</b>
Max. loaf dimensions in in (L x W x H)	17.3" x 12.6" x 6.3"	23.6" x 12.6" x 6.3"
Motor power in kW	0.49	0.49
Type of motor	1ph/120V/60Hz/7.3A	1ph/120V/60Hz/7.3A
Net weight in lbs	331	386

## CHOICES

Slice thickness options	from 3/8" to 1 1/4"	from 3/8" to 1 1/4"
-------------------------	---------------------	---------------------

## OPTIONS

1.6" height adjustment	•	•
Double slice thickness		•
Rear safety cover	•	•





## Contact

Maintain contact with your customers while the bread is sliced automatically.

## Ease of operation

The slicing cycle is started simply by closing the safety cover. The safety cover opens automatically when slicing is complete. Front loading and the easily accessible crumb collector ensure ergonomic and comfortable ease of operation.

## Safety and ergonomics

The rear cover allows you to work in complete safety. Insert the loaf, close the cover and that's all there is to slicing the loaf. If the safety cover is forced open the slicer stops automatically.



# Automatic frame slicer

## PICOMATIC ONE

- ✓ Small footprint
- ✓ Can be used on a counter-top or on a base
- ✓ Automatic slicing cycle, simple to use and optimizes time management
- ✓ Ergonomic front loading design
- ✓ Intelligent Slicing Concept
- ✓ 5 years parts / 1 year labor warranty

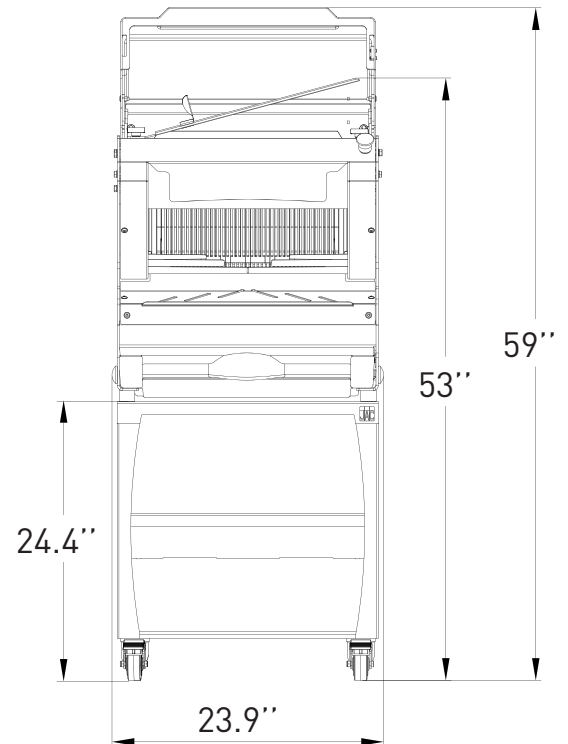
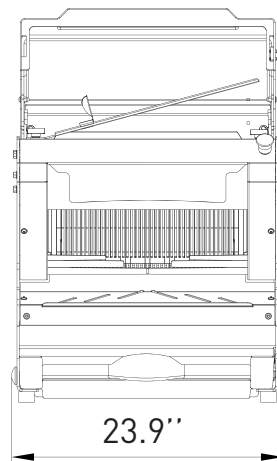
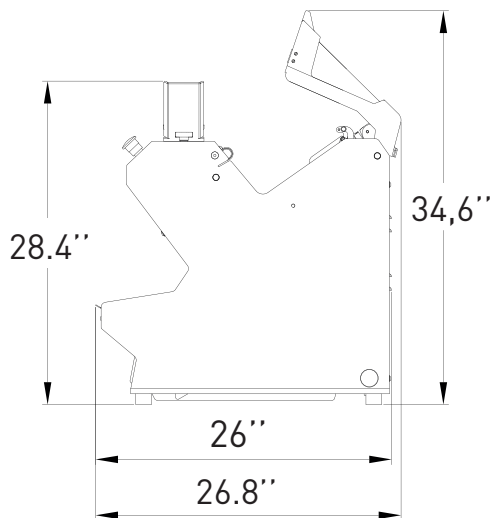



**Intelligent Slicing Concept (JAC patent)**

Continuous automatic control system that slices loaves according to their consistency. This allows open textured, crusty and dense breads to be sliced with equal efficiency.



**Option**

**Front safety cover**

If opened during the cutting cycle, the machine stops.



**Removable crumb collector**

Made of light-weight material, accessible from the front. 1,85 gallons capacity.



**Option**

**Stand with castors**

Provides storage space and mobility.



**JAC FLAPS**

Holds the loaf together for easier handling.

FEATURES		PICOMATIC ONE 450
Max. loaf dimensions in in (L x W x H)		17.3" x 11.8" x 7"
Rear safety cover		•
Motor power in kW		0.49
Type of motor		1ph/120V/60Hz/7.3A
Net weight in lbs		231

CHOICES	
Slice thickness options	from 3/8" to 5/8"

OPTIONS	
Stand with castors	•
Special slice thickness (more than 5/8 ")	•
Front safety covers	•



**ECO+**

# Automatic frame slicer



- ✓ Safety cover to start slicing cycle
- ✓ Safety cover automatically opens upon completion of slicing cycle
- ✓ Very quiet operation, no loud banging noises.
- ✓ 3 speed selector
- ✓ Small footprint
- ✓ large heavy duty crumb tray with ergonomic soft close door
- ✓ 5 year parts warranty
- ✓ ECO+ 600 : 2 slice thicknesses on one slicer

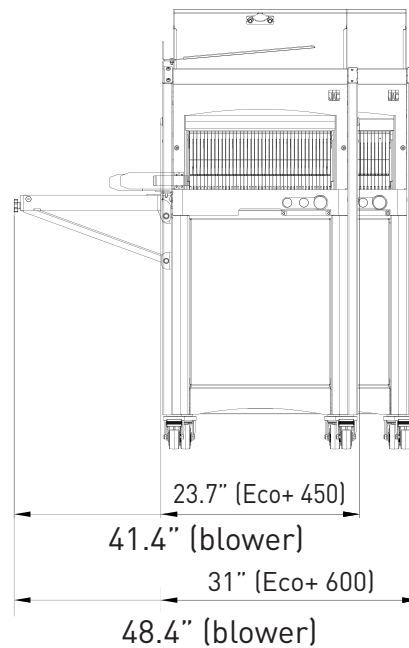
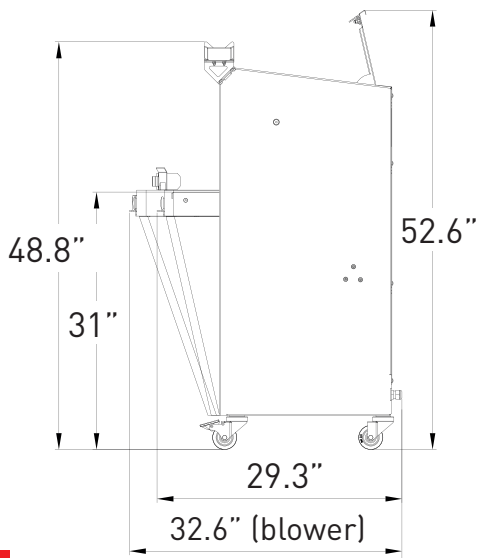

Traditionally Innovative

[www.jac-machines.com](http://www.jac-machines.com)

[office@jac-machines.com](mailto:office@jac-machines.com)



### Intelligent Slicing Concept (JAC patent)

Continuous automatic control system that slices loaves according to their consistency. This allows open textured, crusty and dense breads to be sliced with equal efficiency.

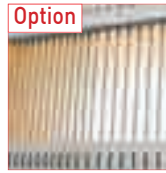

Option

### Double slice thickness

Allows two different slicing widths on the same machine



### Rear safety cover

Closing it initiates the slicing process and it opens automatically when slicing is complete.



Option

### Single light beam safety

Increased accessibility while maintaining an optimum safety level.



### Removable crumb collector

Accessible by tilting the front, cylinder-assisted door. 4.7 gallons capacity.



Option

### Fold down bag blowing table

Saves packaging time.

FEATURES	ECO+ 450	ECO+ 600
Max. loaf dimensions in in (L x W x H)	17.3" x 12.2" x 6.3"	23.6" x 12.2" x 6.3"
Motor power in kW	0.49	0.49
Type of motor	1ph/120V/60Hz/7.3A	1ph/120V/60Hz/7.3A
Net weight in lbs	364	397
Loaf pusher pressure selector	•	•

### CHOICES

Slice thickness options	from 3/8" to 1 1/4"	from 3/8" to 1 1/4"
-------------------------	---------------------	---------------------

### OPTIONS

Fold down bag blowing table	•	•
Optical safety barrier	•	•
Double slice thickness		•
Loaf counter	•	•







## Choice

The luxury of being able to choose! Increase customer loyalty by providing unsurpassed service? Now your customers can choose the slice thickness to suit the style of bread. Thick slices for rustic breads, thin for dense breads... the choice at your finger tips! Your customers will be delighted.

## Be the first

JAC is always the market leader, you can be too by offering this new concept to your customers.

## Technology

Our experience in bread slicing made it possible for JAC to develop a very successful circular blade slicer. Ergonomic, automatic loaf holding, and superior slicing quality. Every detail has been designed using a host of technologies to produce a slicer which is very simple to use.



# Automatic circular blade slicer

## VARIA PRO

- ✓ Choice of slice thickness
- ✓ Choice of number of slices, half loaf or full loaf
- ✓ Maximum safety
- ✓ Eye catching design
- ✓ Stainless Steel frame
- ✓ Smallest footprint
- ✓ 5 years parts / 1 year labor warranty

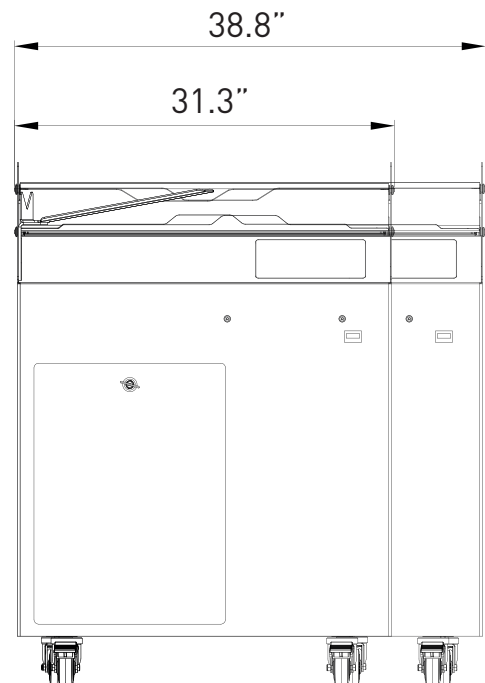
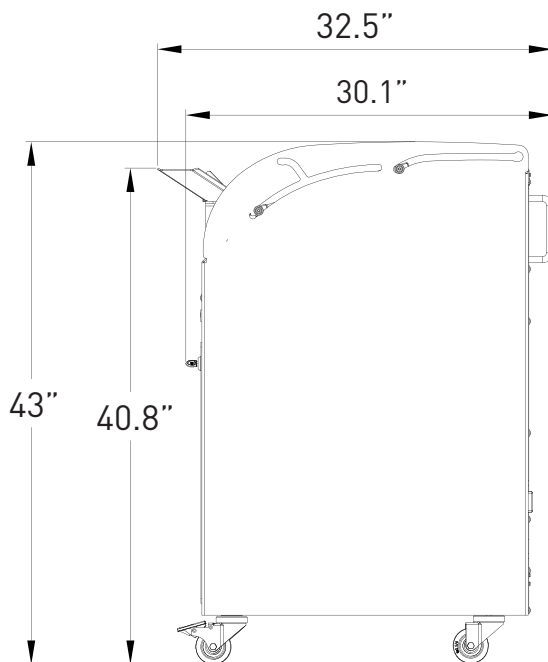

Traditionally Innovative

[www.jac-machines.com](http://www.jac-machines.com)

[office@jac-machines.com](mailto:office@jac-machines.com)



**Automatic claw**  
 Stabilizes the loaf during slicing  
 - Ergonomic  
 - ease of use  
 - Efficient



**Teflon-coated circular blade**  
 Non-stick for the clean cutting of all types of bread.



**Control panel**  
 Allows the user to choose the thickness and number of slices  
 - From 3/16th to 1"  
 - Singles, half-loaf or whole loaf



**Removable crumb collector**  
 Made of light-weight material  
 4.7 gallons capacity.



**Safety cover**  
 Locked during the cutting cycle,  
 prevents access to the blade.



**Option**

**Touch keypad**  
 Quick and easy to use.

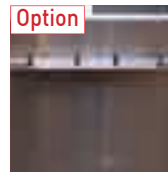

**Option**

**Bag holder**  
 Facilitates bread bagging

## VARIA PRO 800

### FEATURES

Max. loaf dimensions in in (L x W x H)	14.17" x7.87" x 4.9"
Slice thickness options	from 3/16th to 1"*
Type of motor	3ph/208V/60Hz/4.1A
Motor power in kW	1.1
Net weight in lbs	485
Cleaning position	•
Blade type and dimensions	16.5" diameter. Teflon-coated
Standard colour white and grey (not compatible with stainless steel exterior)	•

### OPTIONS

Stainless steel exterior	•
Touch keypad	•
Bag holder	•

\* Thickness to be determined according to the type of bread.



NOUS PRODUISONS PLUS DE QUATRE MILLIARDS DE FOURNÉES DE PAIN PAR JOUR. ET VOUS LE SAVOUREZ QUAND VOUS VOULEZ.



## Quality

The self-service slicing concept allows your customers to slice their own bread at the moment of purchase. This guarantees that the bread stays fresher longer, attracts customers and boosts sales.

## Productivity

Never lose a sale. The Self Service slicer allows staff to focus on other tasks and the customer to slice their own bread as they please. An idea that a lot of supermarket customers will find attractive in an ever more competitive environment.

## Safety and ease of use

More than a machine, self-service slicing is a concept: Simple step by step guide, safety covers, bread holding system. Our experience allows us to always be one step ahead.



# Self-service frame slicer

# NEW SELF

- ✓ Customer Self service slicer
- ✓ Over 700 installed nationwide
- ✓ Floor standing: will not topple over like top heavy stand mounted slicers
- ✓ Automatic start when safety cover is closed no pushing buttons
- ✓ Large heavy duty crumb tray with ergonomic soft close door
- ✓ 5 year parts warranty

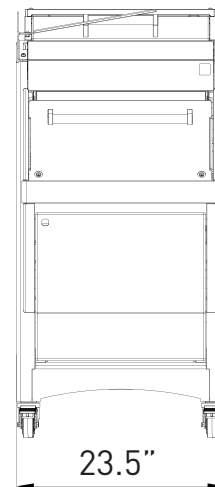
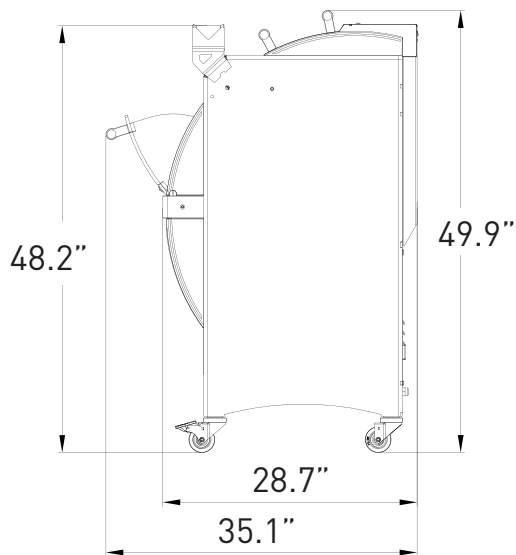

Traditionally Innovative

[www.jac-machines.com](http://www.jac-machines.com)

[office@jac-machines.com](mailto:office@jac-machines.com)



**Intelligent Slicing Concept (JAC patent)**

Continuous automatic control system that slices loaves according to their consistency. This allows open textured, crusty and dense breads to be sliced with equal efficiency.



**JAC FIX**

Holds the loaf together for easier handling at the exit of the slicer.



**Front safety cover**

Locked during the slicing process for maximum safety.



**Removable crumb collector**

Completely safe. Accessible by tilting the front door. 6.6 gallons capacity.



**Rear safety cover**

Closing it initiates the slicing process and it remains mechanically and electrically locked during cutting.

<b>FEATURES</b>		<b>NEW SELF 450</b>
Max. loaf dimensions in cm (L x W x H)		17.3" x 12.2" x 6.3"
Motor power in kW		0.49
Type of motor		1ph/120V/60Hz/7.3A
Net weight in lbs		462
JAC FIX		•

<b>CHOICES</b>	
Slice thickness options	from 3/8" to 1 1/4"







## Quality

The self-service slicing concept allows your customers to slice their own bread at the moment of purchase. This guarantees that the bread stays fresher longer, attracts customers and boosts sales.

## Choice

Allowing your customers to choose the slice thickness they want for the type of bread. This new service will help you grow customer loyalty.

## Productivity

Never lose a sale. The Self Service slicer allows staff to focus on other tasks and the customer to slice their own bread as they please. An idea that a lot of supermarket customers will find attractive in an ever more competitive environment.

## Safety, ease of use and hygiene

More than a machine, self-service slicing is a concept: Simple step by step guide, safety covers, bread holding system. Our experience allows us to always be one step ahead.



# Self-service circular blade slicer

## **VARIA** ***SELF***

- ✓ Choice of 3 pre set slice thicknesses
- ✓ Maximum safety
- ✓ Eye catching desing
- ✓ Stainless steel Frame
- ✓ Smallest footprint
- ✓ 5 years parts / 1 year labor warranty

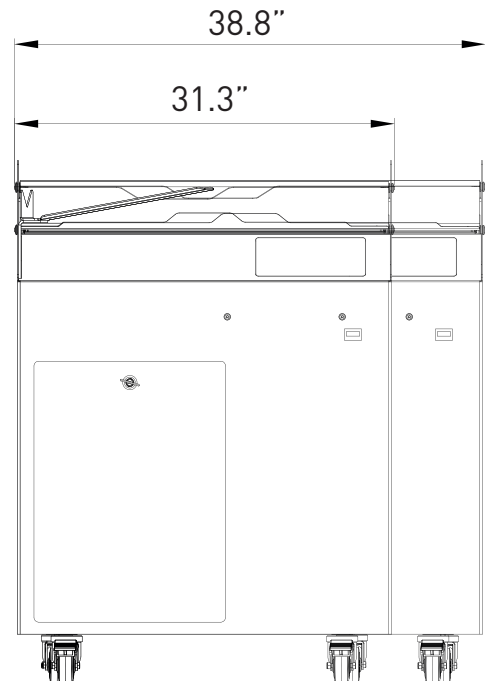
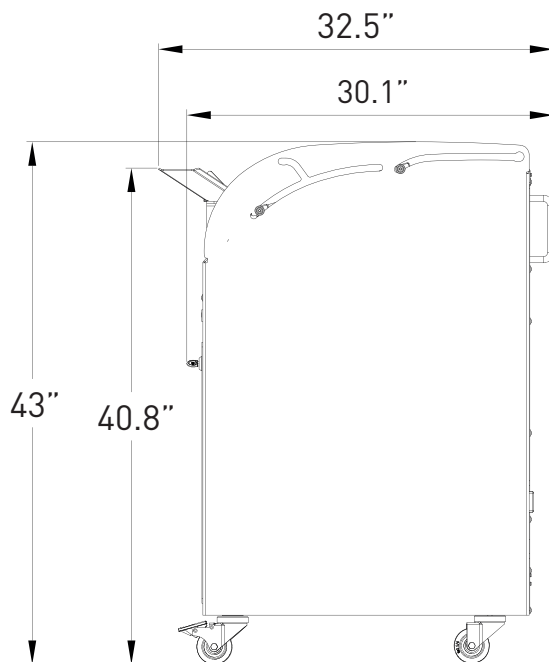

Traditionally Innovative

[www.jac-machines.com](http://www.jac-machines.com)

[office@jac-machines.com](mailto:office@jac-machines.com)



**Automatic claw**  
 Stabilizes the loaf during slicing  
 - Ergonomic  
 - ease of use  
 - Efficient



**Teflon-coated circular blade**  
 Non-stick for the clean cutting of all types of bread.



**Control panel**  
 Allows the user to select a thickness between 3/16th and 1"\*



**Removable crumb collector**  
 Made of light-weight material  
 4.75 gallons capacity.



**Safety cover**  
 Locked during the cutting cycle, prevents access to the blade.

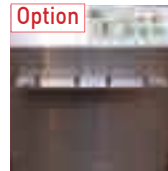

**Option**  
**Bag holder**  
 Facilitates bread bagging

### VARIA PRO 800

#### FEATURES

Max. loaf dimensions in in (L x W x H)	14.17" x7.87" x 4.9"
Slice thickness options	From 3/16th to 1"*
Type of motor	3ph/208V/60Hz/4.1A
Motor power in kW	1.1
Net weight (in kg)	485
Cleaning position	•
Blade type and dimensions	16.5" diameter. Teflon-coated
Standard colour white and grey (not compatible with stainless steel exterior)	•

#### OPTIONS

Stainless steel exterior	•
Bag holder	•

\* Thickness to be determined according to the type of bread.

<p><b>LES VIANDE</b></p> <p>...udo tartare, laitue) 3,8 €</p> <p>...are maison, crudités) 4,4 €</p> <p>...uda tartare crudités) 4,5 €</p> <p>...agnard 4,7 €</p> <p>...ce moutarde miel 4,7 €</p> <p>...s, parmesan 4,7 €</p>	<p><b>LES ROASTBEEFS</b></p> <p>Le carpaccio (roastbeef roquette, fines de sel, parmesan) 4,7 €</p> <p>Le scottish (roastbeef tartare, crudités) 4,7 €</p> <p>Le british (roastbeef sauce moutarde laitue, Navarin) 4,7 €</p>	<p><b>LES FROMAGES</b></p> <p>Le brie (brie, atop de linge, parmesan, table) 4,4 €</p> <p>Le chèvre (chèvre, tomates confites, roquette) 4,4 €</p> <p>Le chèvre bis (chèvre, atop de linge, tottu, coriandre, roquette) 4,4 €</p>	<p><b>LES ITALIENS</b></p> <p>Le mozarella (mozzarella, tomates, parmesan, table) 4,4 €</p> <p>Le ricotta (ricotta, jamb, le fromage, tomates, parmesan) 4,4 €</p> <p>Le ricotta bis (ricotta, tomates, jamb, tomates, parmesan) 4,4 €</p> <p>Le parme (jamb, de parme, mozzarella, tomates, parmesan) 4,4 €</p> <p>Le toscan (jamb, de parme, mozzarella, tomates, parmesan) 4,4 €</p> <p>Le romain (gratin, jamb, de parme, jamb, tomates, jamb, tomates) 4,4 €</p> <p>Le romagnol (sopressa, moquette, parmesan) 4,4 €</p> <p>Le provolone (jamb, de parme, provolone, jamb, tomates, jamb, tomates) 4,4 €</p> <p>L'aubergine (jamb, de parme, aubergine, jamb, tomates, parmesan, jamb, tomates) 4,4 €</p>	<p><b>LES PIZZONS</b></p> <p>Le magliorini (saucis de viande, jamb, tomates) 4,4 €</p> <p>Le marinari (saucis de viande, jamb, tomates) 4,4 €</p> <p>Le salade (saucis de viande, jamb, tomates) 4,4 €</p> <p>Le pizza (saucis de viande, jamb, tomates) 4,4 €</p>	<p><b>LES CHAUDS</b></p> <p>Le parme chaud (saucis de viande, jamb, tomates) 4,4 €</p> <p>Le tomate (saucis de viande, jamb, tomates) 4,4 €</p> <p>Le jamb (saucis de viande, jamb, tomates) 4,4 €</p> <p>Le gomme (saucis de viande, jamb, tomates) 4,4 €</p> <p>Le fromage (saucis de viande, jamb, tomates) 4,4 €</p> <p>Le provolone (saucis de viande, jamb, tomates) 4,4 €</p> <p>Le aubergine (saucis de viande, jamb, tomates) 4,4 €</p> <p>Le omelette (saucis de viande, jamb, tomates) 4,4 €</p> <p>Le jamb (saucis de viande, jamb, tomates) 4,4 €</p> <p>Le tomate (saucis de viande, jamb, tomates) 4,4 €</p>
-------------------------------------------------------------------------------------------------------------------------------------------------------------------------------------------------------------------------------	-------------------------------------------------------------------------------------------------------------------------------------------------------------------------------------------------------------------------------	-----------------------------------------------------------------------------------------------------------------------------------------------------------------------------------------------------------------------------------	----------------------------------------------------------------------------------------------------------------------------------------------------------------------------------------------------------------------------------------------------------------------------------------------------------------------------------------------------------------------------------------------------------------------------------------------------------------------------------------------------------------------------------------------------------------------------------------------------------------------------------------------------------------------------------------------------------------	--------------------------------------------------------------------------------------------------------------------------------------------------------------------------------------------------------------------------------------------------------------------	-----------------------------------------------------------------------------------------------------------------------------------------------------------------------------------------------------------------------------------------------------------------------------------------------------------------------------------------------------------------------------------------------------------------------------------------------------------------------------------------------------------------------------------------------------------------------------------------------------------------------------





## Growing market

With strong growth in the Deli/ Sandwich market. JAC's ZIP slicer can meet your immediate need with our "on Demand" slicer. Slice baguette, buns, bagels, subs quickly and easily.

## Changing Habits

Because eating habits are changing, JAC is offering a slicer with several options: full or hinged partial slicing, height of the blade in the bread, adjustable holding guides.

## Ergonomic concept

The high output means that you need to be properly organised. JAC has created a set of accessories that will make flow management easier: a special base and sliced bread retrieval trays on a base with casters.



# Bun & bagel slicer



- ✓ Very quiet operation
- ✓ Variable blade settings
- ✓ Variety of cutting heights and depths
- ✓ Can handle large bagels
- ✓ Heavy duty design
- ✓ Thruput of up to 2000 slices/hour
- ✓ 5 years parts / 1 year labor warranty



Zip+scorpion

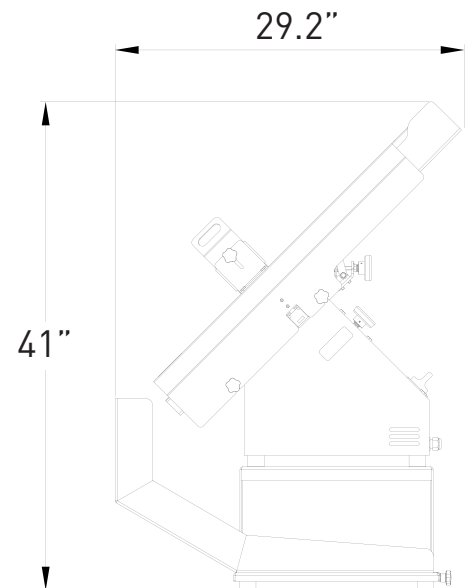
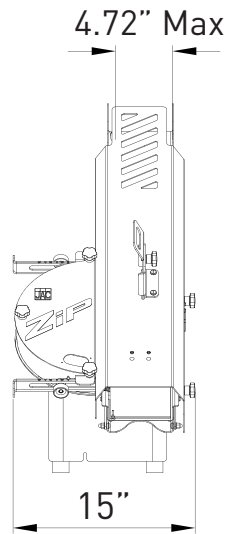
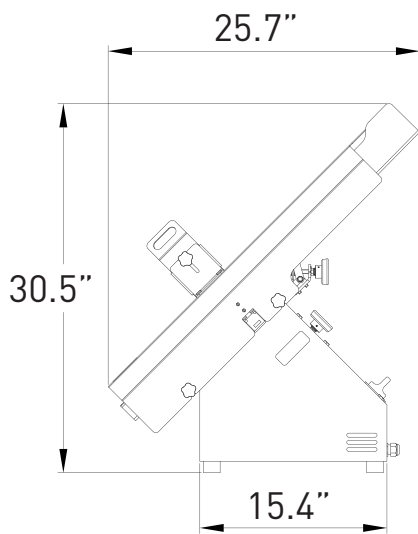



**Adjustable cutting chute**  
The adjustable height and width allow several types of loaves to be held, while ensuring a clean, precise cut.



**Option** Stainless steel scorpion base unit

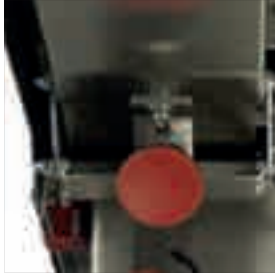

**Blade adjustment handle**  
To set the height and depth of the cut in the bread.



**Option** Stainless steel base and cart with bins



**Stainless steel shutter**  
Finger protection system fixed at the outlet of the cutting area.

FEATURES	ZIP
Max/min bread dimensions (W x H) in mm	2.36" x 2.36" / 4.72" x 3.14"
Motor power in kW	0.49
Type of motor	1ph/120V/60Hz/6.6A
Net weight (in kg)	77.16
Blade type and dimensions	11.8" diameter steel

### OPTIONS

Scorpion base unit	•
Stainless steel base	•
Cart with bins	•







## Flow

Slicing is a critical station in your production and efficient solutions are required.

In the same way that your oven has to adapt to your production volume, managing the slicing flow also has to be optimised. JAC has a solution for you.

## Productivity

Our continuous feed slicers are based on a continuous loading / slicing / unloading. Whether using a motorised belt or a loading ramp, a continuous supply to the slicing blades allows rates of 1000 loaves an hour to be achieved.

## Packaging

Packaging solutions are available to match the output of all our slicers. Whether you are looking for a bag blower or a bag closer, JAC provides you with a complete solution.



# CHUTE

## Continuous cut slicer

- ✓ Designed for cutting soft white loaves
- ✓ Maximum output thanks to a continuous cycle
- ✓ Minimum space requirement
- ✓ Economic
- ✓ Front-loading for ergonomic efficiency
- ✓ 5 years parts / 1 year labor warranty

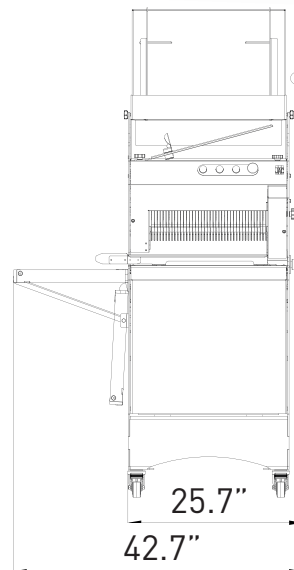
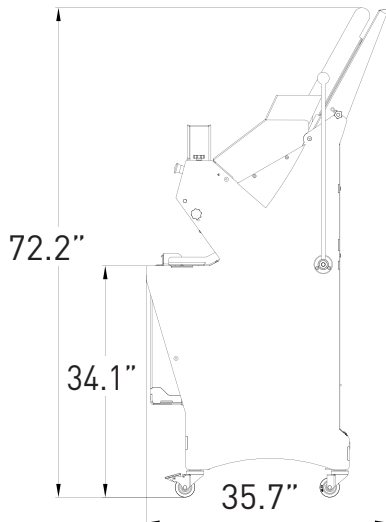

Traditionally Innovative

[www.jac-machines.com](http://www.jac-machines.com)

[office@jac-machines.com](mailto:office@jac-machines.com)



**Loading ramp**  
Fitted with side guides, increases loading capacity.



**Removable crumb collector**  
Accessible by tilting the front cylinder-assisted door. 4.75 gallons capacity.



**Adjustable bread holder**  
Adjusts the pressure on the bread to ensure a clean, precise quality of cut.



**Bread exit guides**



**Lever on the side**  
Allows the final loaf to be cut completely safely.



**Fold down bag blowing table**  
Saves packaging time.

## FEATURES

### CHUTE 450

Max. loaf dimensions in in (L x H)	17.3" x 6.3"
Motor power in kW	0.49
Type of motor	1ph/120V/60Hz/7.3A
Net weight in lbs	507

## CHOICES

Slice thickness options	from 3/8th to 1 1/4"
-------------------------	----------------------

## OPTIONS

Fold down bag blowing table	•
-----------------------------	---



# CHUTE+

## Continuous cut slicer

- ✓ Dual infeed Gravity Feed slicer
- ✓ One slicer two slice thicknesses
- ✓ Minimum space requirement
- ✓ Ergonomic
- ✓ Large capacity crumb tray
- ✓ 5 year parts / 1 year labor warranty

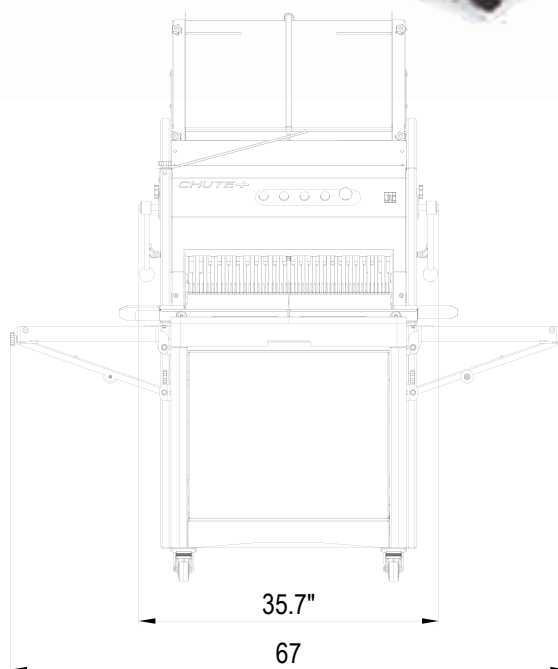
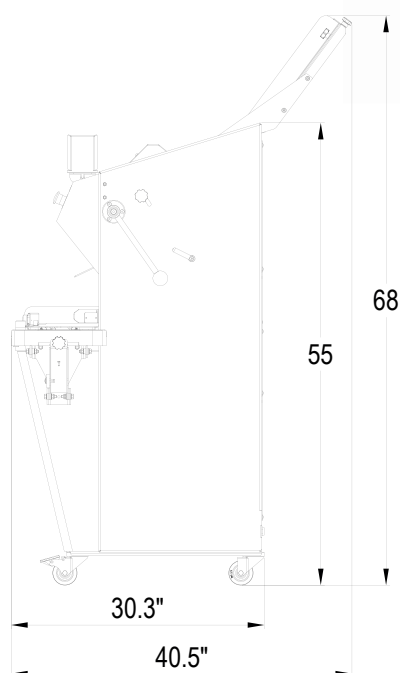

Traditionally Innovative

[www.jac-machines.com](http://www.jac-machines.com)

[office@jac-machines.com](mailto:office@jac-machines.com)



**Loading ramp**  
Fitted with side guides, increases loading capacity.



**Removable crumb collector**  
Accessible by tilting the front cylinder-assisted door. 4.75 gallons capacity.

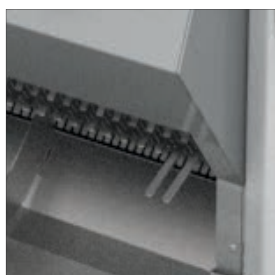

**Adjustable bread holder**  
Adjusts the pressure on the bread to ensure a clean, precise quality of cut.



**Bread exit guides**



**Lever on the side**  
Allows the final loaf to be cut completely safely.



Option

**Fold down bag blowing table**  
Saves packaging time.

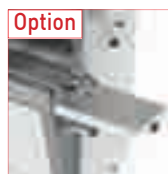

Option

**Double fold down bag blowing table**  
Saves packaging time.

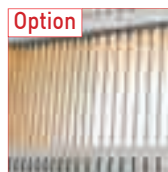

Option

**Double slice thickness**  
Allows two different slicing widths on the same machine

## FEATURES

### CHUTE+ 600

Max. loaf dimensions in in (L x H)	23.6" x 6.3"
Max. loaf dual slice dimensions in in (L x H)	11.8" x 6.3"
Motor power in kW	0.49
Type of motor	1ph/120V/60Hz/7.3A
Net weight in lbs	507

## CHOICES

Slice thickness options	from 3/8" to 5/8"
-------------------------	-------------------

## OPTIONS

Fold down bag blowing table	•
Double fold down bag blowing table	•
Double slice thickness	•
Special slice thickness (more than 5/8 ")	•



# Continuous cut slicers

# FULL

- ✓ Continuous slicing of all types of bread
- ✓ High speed, thanks to motorized in-feed belts
- ✓ Robust
- ✓ Adjustable speed
- ✓ 5 years parts / 1 year labor warranty



Up to 1000 loaves an hour

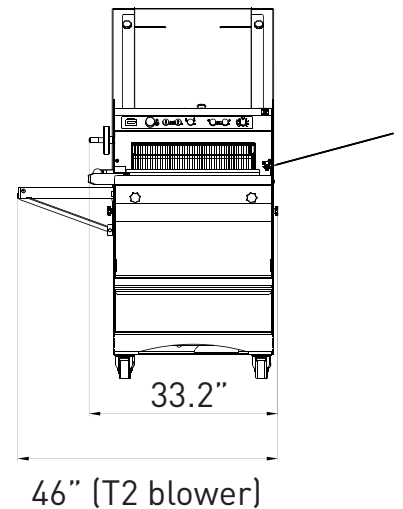
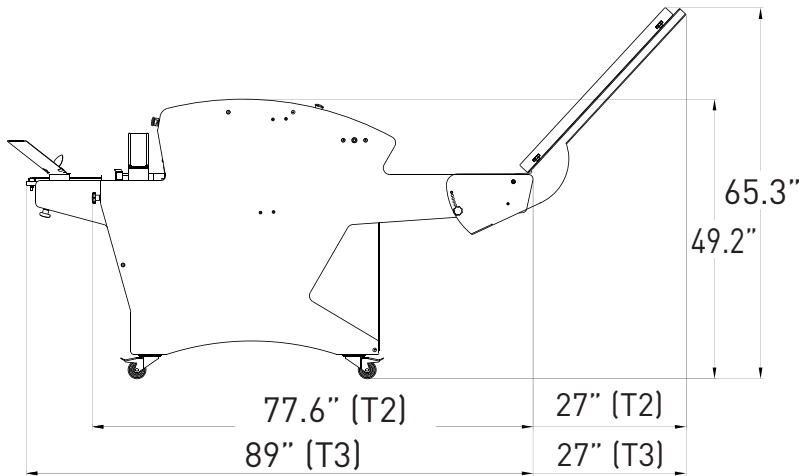

Traditionally Innovative

[www.jac-machines.com](http://www.jac-machines.com)

[office@jac-machines.com](mailto:office@jac-machines.com)



**Front control panel**  
 Motorized adjustment of the upper belt height (height of loaves). Next to the front panel controls, a timer accurately records your working time.



**Full 520 T2**  
**Foldable bag blower**  
 Saves packaging time.



**Rear loading belt**  
 Provides uniform continuous cutting, thanks to adjustable side guides.



**Full 520 T3**  
**Motorised outfeed belt**  
 Fitted with adjustable guides to ensure that the bread is held together after cutting.



**Variable speed drive**  
 Allows the cutting speed to be adjusted to suit the type of bread.

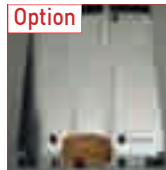

**Option**  
**Loading ramp**  
 Fitted with side guides, increases loading capacity.



**Two crumb collectors**  
 8,7 gallons capacity each.

FEATURES	FULL 520 T2	FULL 520 T3
Max. loaf dimensions in in (W x H)	22" x 6.3"	22" x 6.3"
Foldable bag blower	•	
Motorised outfeed belt		•
Motor power in kW	1.1	1.1
Type of motor	3ph/208V/60Hz/4.8A	3ph/208V/60Hz/4.8A
Net weight in lbs	805	849

CHOICES	FULL 520 T2	FULL 520 T3
Slice thickness options	from 3/8th to 1 1/4"	from 3/8th to 1 1/4"

OPTIONS	FULL 520 T2	FULL 520 T3
Loading ramp	•	•







## Signature bread

Provides more options to help you stand out from the crowd. Offer your customers signature breads with your flavor. JAC sour dough fermentors will help you achieve this time after time.

## Keeping quality and aromas

The liquid starter promotes the development of aromas and maintains the consistency and quality of your breads.

This natural improver helps improve the consistency of your production.

## Simplicity

With Tradilevain, to produce liquid starter every day becomes child's play. Add 50% warm water and 50% flour, start the programme and the machine automatically runs its mixing and agitation cycles.

The agitation technique reduces cleaning and maintenance operations to a minimum.

## Uniformity

Tradilevain is designed to maintain constant acidity and aromas, so that, every day your customers are happy with the consistent quality of their favourite bread.



# TRADILEVAIN

- ✓ Starter uniformity and stability
- ✓ Simple usage and easy cleaning
- ✓ Stainless steel structure and exterior
- ✓ Exclusive mixing system
- ✓ 5 years parts / 1 year labor warranty



TL40

TL105

TL220

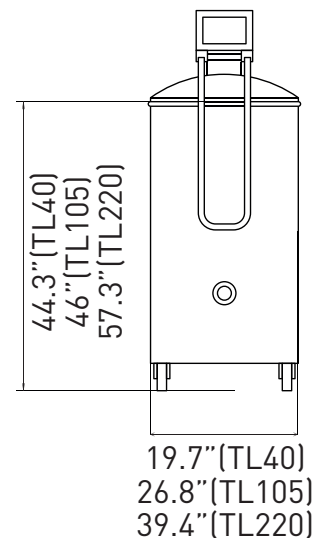
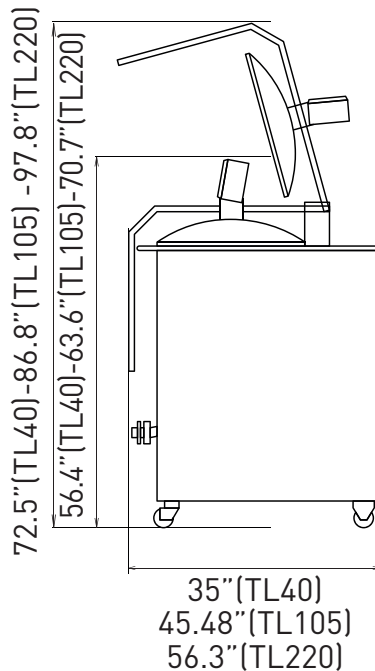

Traditionally Innovative



**Control panel**  
Controls and configures the mixing, fermentation and conservation cycles. Informs the user about how cycles are progressing.



**Two draining outlets.**  
The upper outlet tap retains a minimum starter safety volume. The lower outlet allows complete draining.



**Exclusive mixing system.**  
Programmed to ensure ideal agitation. The immersed helix also reduces cleaning and maintenance operations to a minimum.



**Watertight lid**  
Fitted with a removable hermetic seal, the Tradilevain ensures a high degree of stability in the sourdough starter.

Stable pH over time

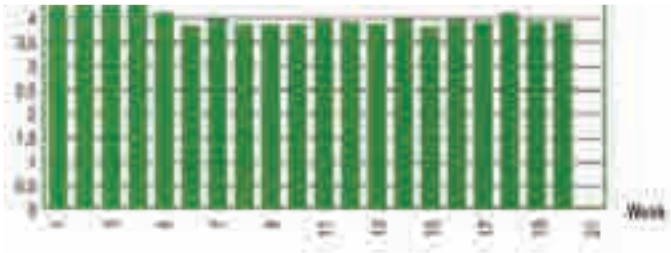

Stable microbial balance over time

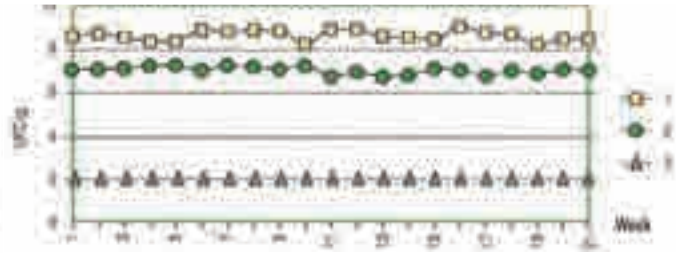

FEATURES	TL40	TL105	TL220
Usable capacity in gallons	10.5	27.7	58.1
Tank capacity in gallons	21.1	55.5	119
Motor power in kW	1.6	3.6	6.25
Type of motor	3ph/208V/60Hz/10A	3ph/208V/60Hz/15.3A	3ph/208V/60Hz/33A
Net weight in lbs	441"	639.3 "	926 "





## Robust

Dividing doughs puts a lot of stress on machines, JAC dividers are built with a reinforced piston, cast aluminium cutters on square DIV with Easy Clean treatment, Start and Stop system, sharpened stainless steel knives, square stainless steel tank. These features make JAC the industry benchmark.

## Caring for the dough

The hydraulic divider is an essential component in the baking process. JAC Dividers are robust on firm doughs and gentle on fermented doughs to respect crumb structure.

## Ergonomics and sanitation

A convenient working height, ergonomic handle, flour splash prevention system and automatic knife retraction are standard. These features come from years of technical experience.



# Hydraulic dividers

## DIV DIV-R

- ✓ Increased productivity
- ✓ Simplified cleaning
- ✓ Silent (-65dB)
- ✓ Adjustable pressure (only on DIV-R)
- ✓ Stainless steel exterior
- ✓ 20 divisions
- ✓ 5 years parts / 1 year labor warranty



DIV ●

DIV-R ■

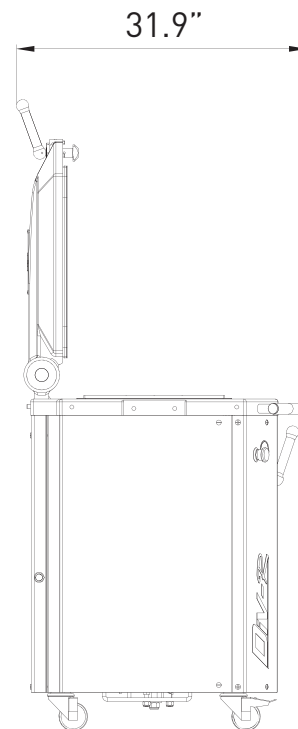
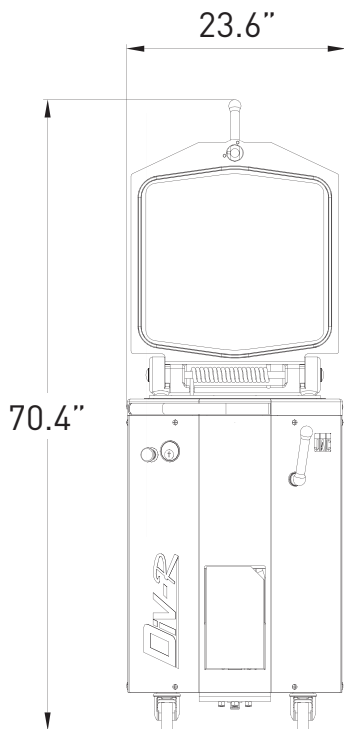

Traditionally Innovative

[www.jac-machines.com](http://www.jac-machines.com)

[office@jac-machines.com](mailto:office@jac-machines.com)



**Sharpened stainless steel knives**  
Includes automatic retraction for easy maintenance

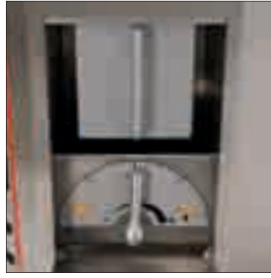

**DIV-R**  
**Adjustable pressure**  
Prevents de-gassing of doughs.



**DIV-R** ■  
**Easy Clean treatment of the cast iron head**  
This extremely tough treatment is impregnated into the material; its exceptional non-stick qualities improve over time.



**DIV-R**  
**Flour splash prevention system**  
Prevents flour dispersal into your bakery.



**DIV-R** ■  
**Stainless steel tank**  
For optimum hygiene and easy maintenance



**DIV** ●  
**Protection / movement handle**  
Allows easy handling of the machine.

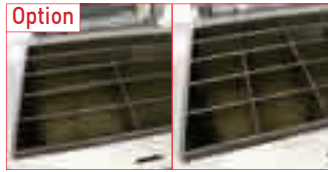

**DIV-R** ■  
**10 / 20 divisions**  
Allows cutting in 10 divisions (9" x 2.95") or 20 divisions (4.5" x 2.95")

## FEATURES

	DIV 20 ●	DIV-R 20 ●	DIV-R 20 ■
Dimensions of square tanks (L x W x H) in in			18.11" x 15.2" x 4.9"
Dimensions of round tanks (L x W x H) in in	18.11" x 4.72"	18.11" x 4.72"	
Dimension of cuts of square tanks (LxW) in in			4.5" x 2.95"
Max/min weight of dough pieces in oz (dough dependent)	3.5 / 31,7	3.5 / 31,7	5.3 / 33.5
Chamber capacity in lbs	39,7	39,7	41.9
Min / max weight in oz in 10-division position			10.6 / 67
Flour splash prevention system		●	●
Automatic knife retraction	●	●	●
Adjustable pressure		●	●
Flour recovery		●	●
Protection handle		●	●
Motor power in kW	1.8	1.8	1.8
Type of motor	3ph/208V/60Hz/11A	3ph/208V/60Hz/11A	3ph/208V/60Hz/11A
Net weight in lbs	573	584	584
Easy Clean treatment	●	●	●

## OPTIONS

Protection handle	●		
10 / 20 divisions			●

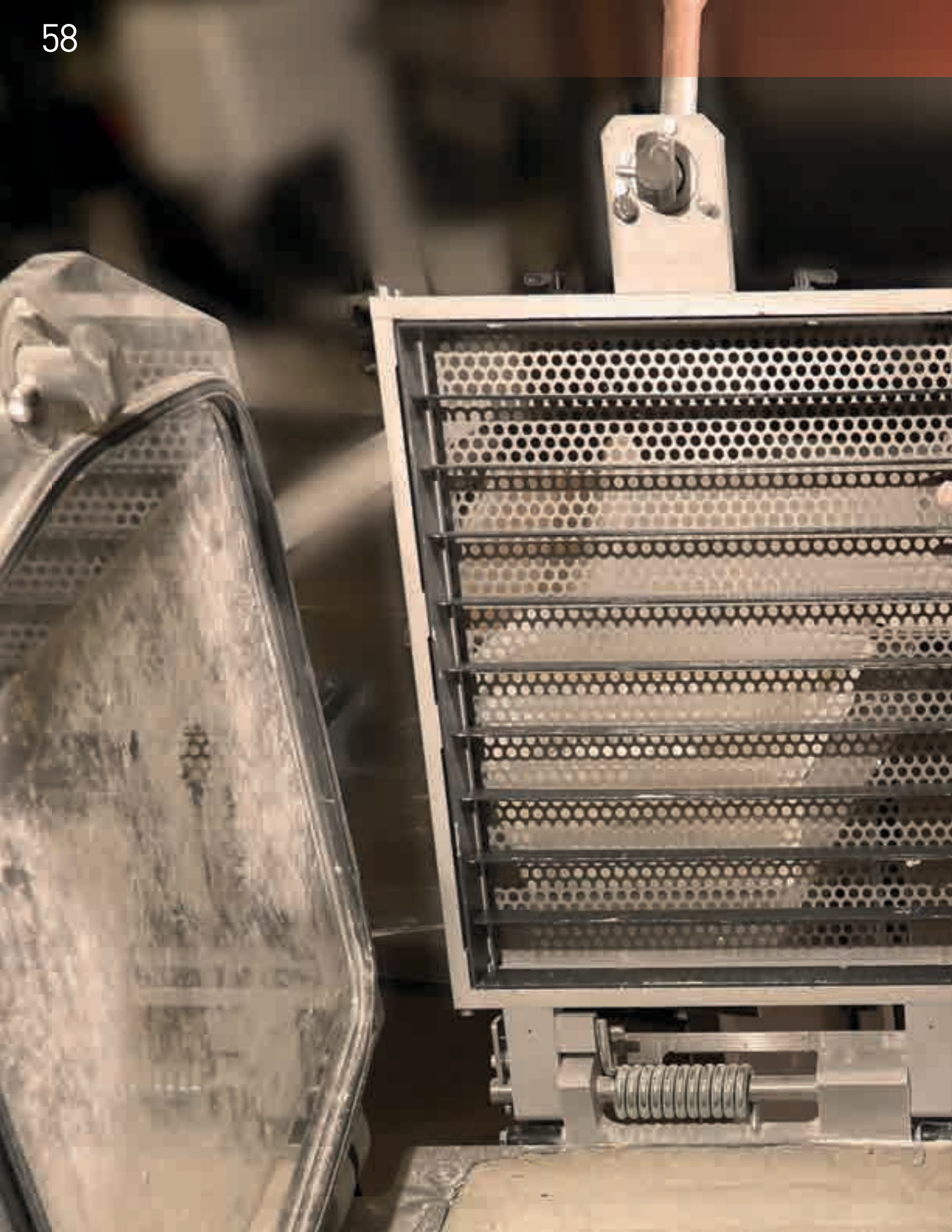





## (R)evolution

Re-organise your bakery. Offer warm bread throughout the day. Improve your profitability with up to 72-hour dough management. Increase your responsiveness with a concept that allows you to bake bread in 30 minutes and save space at the same time.

## A genuine range of products

Diviform+: All types of dough thanks to the pressing plate.

Tradiform: All types of dough, divide using the chamber or cutting grids.

## An overall concept

A work table, a catalogue containing 80 different grids, racks with convenient size trays: everything to provide you with a complete solution and efficient working environment.



# TRADIFORM

- ✓ Modular solution with cutting/forming grids
- ✓ Quick, efficient
- ✓ Versatile
- ✓ Minimal space required
- ✓ Pressure plate
- ✓ Stainless steel exterior
- ✓ 5 years parts / 1 year labor warranty



Side frame included. Sold without grid

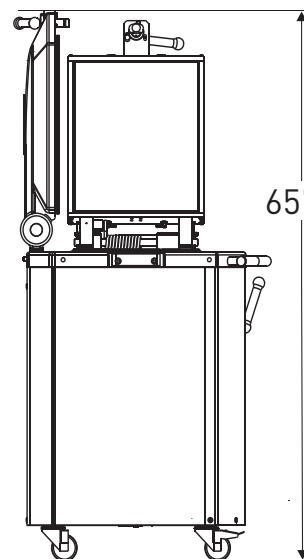
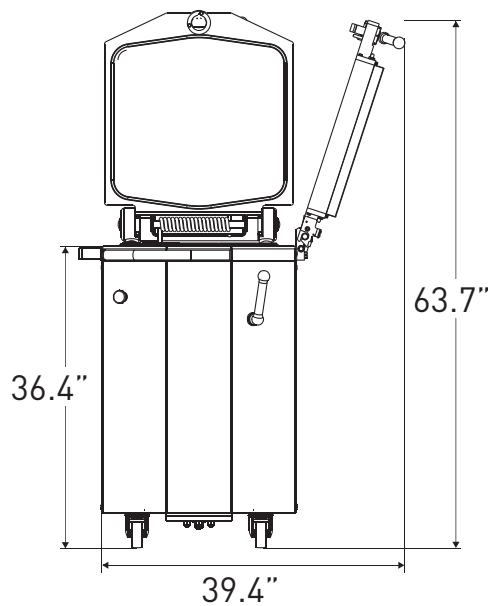

Traditionally Innovative



## Easylock

**Accroche automatique du support de grilles**  
Lors de sa fermeture, le support grille se verrouille automatiquement et lance le cycle auto de division.



**Stainless steel tank and knives**  
Includes automatic retraction for easy maintenance.



## Easy Clean

**Easy Clean treatment of the cast iron head**  
This extremely tough treatment is impregnated into the material; its exceptional non-stick qualities improve over time.



**Flour splash prevention system**  
Prevents flour dispersal.



## click&cut!

Système de changement rapide et ergonomique de grille



**Protection / movement handle**  
Allows easy handling of the machine.



**Adjustable pressure**  
Prevents de-gassing of the different types of dough.



**Option** Left or right side grid storage

## FEATURES

## TRADIFORM

Dimensions of tanks (L x W x H) in in	18.1" x 15.2" x 4.9"
Dimensions of heads (L x W) in in	4.5" x 2.9"
Min/max weight of dough pieces in oz	5.3 / 33.5
Tank capacity in lbs	41.9
Pressure plate	•
Automatic knife retraction	•
Flour splash prevention system	•
Supplied with a grid frame	•
Motor power in kW	1.8
Type of motor	3ph/208V/60Hz/11A
Net weight in lbs (including frame)	628.3

## OPTIONS

Left or right side grid storage

•

**The grids catalogue offers more than 100 different grids. The choice is yours!**

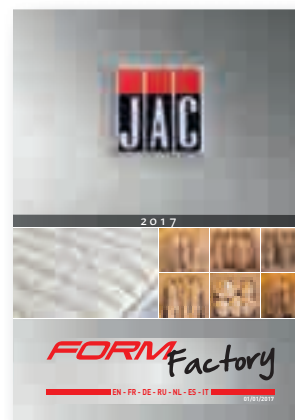



# EASYFORM

- ✓ Fully automatic pressing and dividing cycle
- ✓ Fast, efficient operation
- ✓ Adjustable pressure settings
- ✓ Choice between half and full tank
- ✓ Automatic grid locking system



Side frame included. Sold without grid

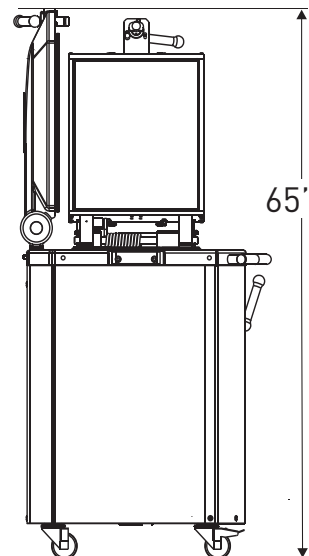
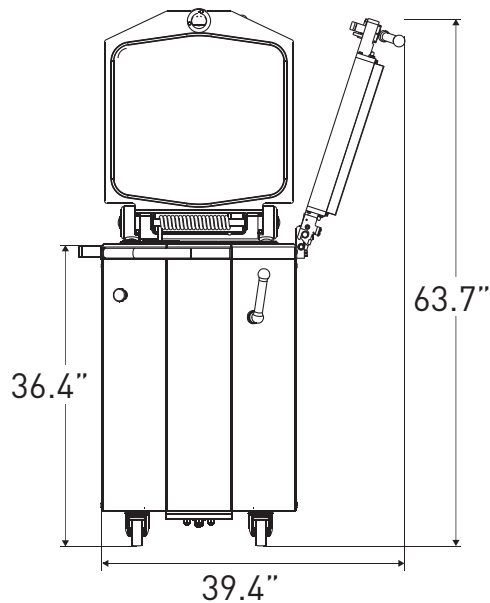

Traditionally Innovative



## Fullmatic

### Pressure setting time

To get the best dividing without de-gassing the dough.

Packing or cutting automatic cycle

### Choice between full or half-full tank

To optimize the dough volume.



## Easylock

### Automatic grid support locking system

You just close the grid and it's locked. Press the hook and the grid opens.



### Easy Clean treatment of the cast iron head

This extremely tough treatment is impregnated into the material; its exceptional non-stick qualities improve over time.



## click&cut!

Quick and ergonomic grid changing system.



Flour splash prevention system  
Prevents flour dispersal.



Adjustable pressure  
Prevents de-gassing of the different types of dough.



Stainless steel tank and knives  
Includes automatic retraction for easy maintenance.

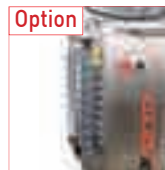

Option

Left or right side grid storage

## FEATURES

EASYFORM	
Dimensions of tanks (L x W x H) in in	18.1" x 15.2" x 4.9"
Dimensions of heads (L x W) in in	4.5" x 2.9"
Min/max weight of dough pieces in oz	5.3 / 33.5
Tank capacity in lbs	41.9
Pressure plate	•
Automatic knife retraction	•
Flour splash prevention system	•
Supplied with a grid frame	•
Motor power in kW	1.8
Type of motor	3ph/208V/60Hz/11A
Net weight in lbs (including frame)	628.3
Fullmatic	•
Easylock	•

## OPTIONS

Left or right side grid storage | •

The grids catalogue offers more than 100 different grids. The choice is yours!



# FORM FACTORY



The grids catalogue offers more than 100 different grids.  
The choice is yours!

## ANGLED KNIFE GRIDS

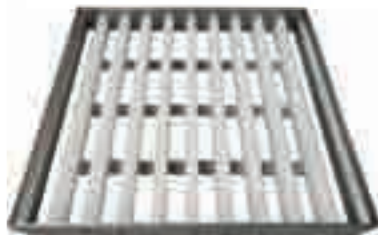

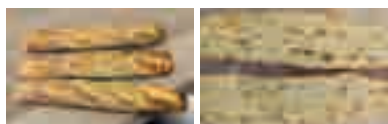

JAC now offers grids with angled knives that allow the dough to knit together perfectly.







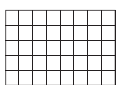











<b>D5</b>	OPTGRILFOR502	5 1x5	18.54" x 3"	14→28 oz		
<b>D5</b>	OPTGRILFOR501	5 5x1	3.67" x 15.3"	14→28 oz		
<b>D6</b>	OPTGRILFOR601	6 1x6	18.54" x 2.5"	11.75→23.5 oz		
<b>D8</b>	OPTGRILFOR802	8 1x8	18.54" x 1.85"	8.8→17.6 oz		
<b>D8</b>	OPTGRILFOR801	8 8x1	2.25" x 15.3"	8.8→17.6 oz		
<b>D9</b>	OPTGRILFOR901	9 9x1	2" x 15.3"	7.83→15.66 oz		
<b>D10</b>	OPTGRILFOR1001	10 10x1	1.77" x 15.3"	7→14 oz		
<b>D12</b>	OPTGRILFOR1201	12 2x6	9.2" x 2.5"	5.9→11.75 oz		
<b>D18</b>	OPTGRILFOR1801	18 9x2	2" x 7.6"	3.9→7.83 oz		
<b>D20</b>	OPTGRILFOR2001	20 10x2	1.77" x 7.6"	3.52→7.05 oz		

## TEFLON-COATED STAINLESS STEEL GRIDS

						
<b>D5</b>	OPTGRIL502	5 5x1	3.6" x 15.3"	21→35 oz		
<b>D10</b>	OPTGRIL1001	10 10x1	1.73" x 15.3"	10.6→17.6 oz		
<b>D10</b>	OPTGRIL1003	10 5x2	3.6" x 7.6"	10.6→17.6 oz		
<b>D12</b>	OPTGRIL1201	12 4x3	5" x 4.6"	8.8→14.7 oz		
<b>D20</b>	OPTGRIL2001	20 10x2	1.73" x 7.6"	5.3→8.8 oz		
<b>D30</b>	OPTGRIL3001	30 5x6	3.6" x 2.44"	3.5→5.9 oz		
<b>D40</b>	OPTGRIL4001	40 8x5	2.2" x 2.95"	2.64→4.4 oz		

**Non-standard grids on request (see FORM FACTORY catalogue).**

## TEFLON-COATED STAINLESS STEEL HALF-GRIDS

						
<b>D2</b>	OPTDEMIGRIL201	2 1x2	7.6" x 8.85"	26.45→44 oz		
<b>D4</b>	OPTDEMIGRIL401	4 2x2	7.6" x 4.37"	13.23→22 oz		
<b>D6</b>	OPTDEMIGRIL601	6 3x2	7.6" x 2.87"	8.8→14.7 oz		
<b>D30</b>	OPTDEMIGRIL3002	30 10x3	5" x 0.78"	1.76→2.9 oz		
<b>D30</b>	OPTDEMIGRIL3001	30 5x6	1.7" x 2.44"	1.76→2.9 oz		

**Non-standard half-grids on request (see FORM FACTORY catalogue).**

## Rack with special trays



14 high-density, food-grade polypropylene trays with lid.

Tray sizes:  
20 1/2" x 15 3/4 x 3"  
(tank dimensions)

Rack constructed entirely of welded stainless steel.

To facilitate and speed up your dividing and moulding process. JAC has designed rack with special trays whose size matches the size of the divider chamber so you can store your various dough recipes in the chamber, ready for division. A real time saving.









## Speed

Wholesale production requires appropriate solutions. JAC offers a range of volumetric dividers suitable for every dough and enabling increased productivity.

## Accuracy

It may appear negligible and yet, five grams of dough per loaf and an annual production of 800,000 pieces adds up to 4,000 kg lost per year. By choosing JAC, you make the right calculation.

## Continuous improvement

Our evolving product range has new features such as stainless steel exteriors and oil recycling for even better sanitation and profitability.



**GDS**

# Volumetric divider

- ✓ Open hopper volumetric divider
- ✓ Stainless steel exterior
- ✓ Consistently accurate scaling
- ✓ High volume
- ✓ Built-in flour dispenser
- ✓ Pre-rounding of dough pieces
- ✓ 5 years parts / 1 year labor warranty

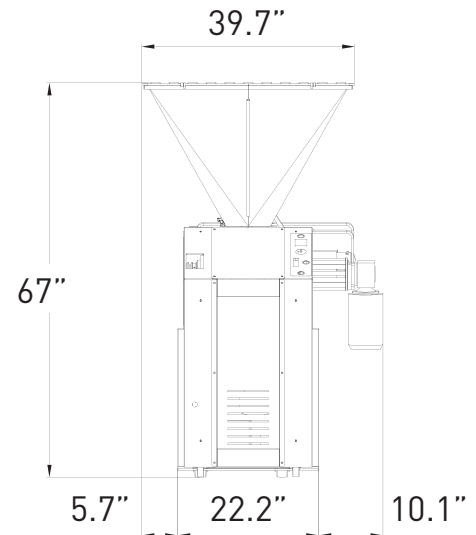
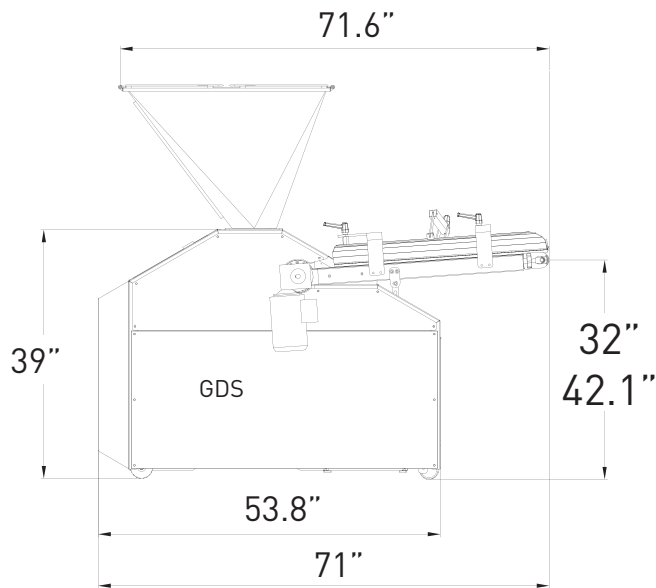



**Outfeed belt scraper**  
The belt is kept clean throughout use.



**Option**

**Built-in flour dispenser**  
Prevents the dough pieces from sticking to the belt.



**Oil recycling system**  
Reduces oil consumption.  
Fitted with a filter and a low level alert.



**Option**

**Moulding plate**



**Option**

**Dough piece lubrication**



**Adjustable pre-rounding**  
Pre-round dough balls on the outfeed belt.

## GDS

### FEATURES

Adjustable speed in pieces per hour	960 - 2000
Teflon-coated hopper. capacity in ounces	4230 oz
Capacity in pounds	260 lbs
Programmable counter. countdown counter	•
Stainless steel drum	•
Triple-seal Rilsan piston	•
Stainless steel exterior	•
Outfeed belt width in in	19.7"
Outfeed belt scraper	•
Adjustable pre-rounding tile	•
Oil recycling system	•
Motor power in kW	2.2
Type of motor	3ph/208V/60Hz/4.7A
Net weight in lbs	1270

### CHOICES

Outfeed belt length in in	41.7"
---------------------------	-------

### OPTIONS

Flour dispenser	•
Dough piece lubrication	•
440lb capacity Teflon-coated stainless steel hopper	•
Dough piece rolling belt	•

	3.14" PISTON	3.94" PISTON	4.33" PISTON	4.72" PISTON	5.12" PISTON
Max/min weight of dough pieces in ounces	1 / 13 oz	1.7 / 24.7 oz	2.47 / 30 oz	3.2 / 35.3 oz	4.6 / 45.8 oz





## Compact

Every inch saved in the bakery is useful. JAC has compact and efficient solutions like integrating our moulders into our proofer systems and retractable unloading belt.

## Adaptable

JAC equipment can be adapted to meet production requirements: with or without rounding belt, standard or wide felt or Arconet troughs, internal or external outlet.

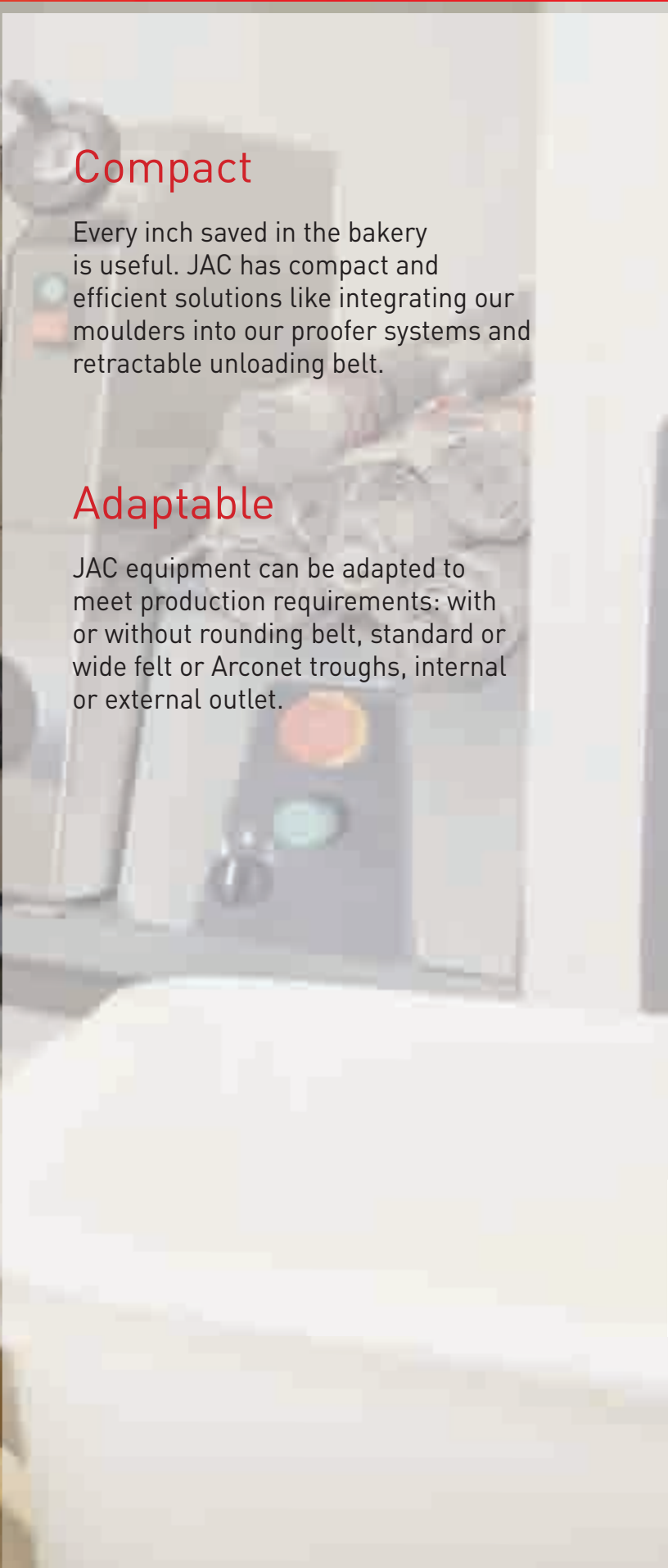



- ✓ Robust and silent
- ✓ Maximum respect for the dough's structure
- ✓ Compact
- ✓ Two trough sizes available
- ✓ Fitted with sockets to connect a moulder and divider
- ✓ 5 years parts / 1 year labor warranty

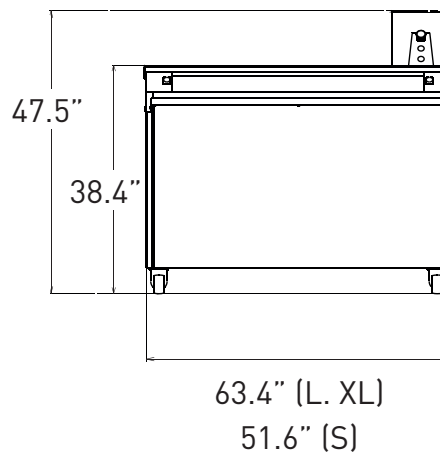
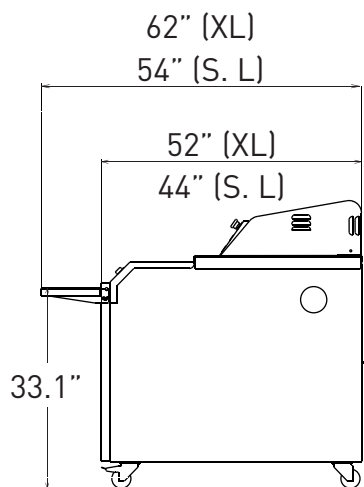

Traditionally Innovative





**Bronze ring gear wheel**  
Reduces friction and extends service life.



**Controls (right/left)**  
Simple and ergonomic



**Foot control**



**Folding rounding tray**

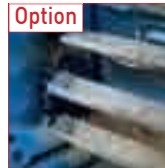

**Germicidal UV lamp with protection and air extractor**  
Sterilises the proofing area and evacuates humidity.

**MB**

**FEATURES**

Synthetic felt troughs	•
Motor power in kW	0.25
Type of motor	3ph/208V/60Hz/1.32A

	<b>MB S</b>	<b>MB L</b>	<b>MB XL</b>
Net weight in lbs	551	573	772
Maximum weight of dough pieces in ounces	33.5	33.5	33.5
Length/width of troughs in in	41.7 x 5.5	53.6 x 5.5	53.6 x 5.5
Total number of troughs	26	26	32
12.35 OZ* DOUGH PIECES			
Number of dough pieces per trough	7	9	9
Maximum capacity	182	234	288
19.5 OZ* DOUGH PIECES			
Number of dough pieces per trough	6	8	8
Maximum capacity	156	208	256
26.5 OZ* DOUGH PIECES			
Number of dough pieces per trough	5	7	7
Maximum capacity	130	182	224
33.5 OZ* DOUGH PIECES			
Number of dough pieces per trough	4	6	6
Maximum capacity	104	156	192

**OPTIONS**

Germicidal UV lamp with protection and air extractor	•
Folding rounding tray	•
Foot control	•
Monofilament troughs	•
Water-repellent troughs (Arconet®)	•

\*The capacities shown are approximate. The nature of the dough, its size, rounding or positioning can alter the number of dough pieces per trough.





## Materials

JAC's latest innovations include dough rollers in food-grade PETP and stainless steel exterior providing strength over time for your moulder and product uniformity.

## Technique

Not all customers have the same requirements or the same products.

## Range

Horizontal or vertical moulding? JAC has both options covered. Horizontal moulding. A more traditional method with minimum stress on the dough. Vertical moulding. For the ability to easily long mould dough pieces, using two counter-rotating belts.

## Innovation

Easily mould flat breads like pita, tortilla, pizza bases all with your bread moulder: JAC patented FORMA moulder can handle all of these products.



# UNIC

# Moulders

- ✓ Vertical moulding to save space
- ✓ Three flattening rollers
- ✓ Ergonomic controls
- ✓ Quick belt change
- ✓ Stainless steel exterior
- ✓ 5 years parts / 1 year labor warranty

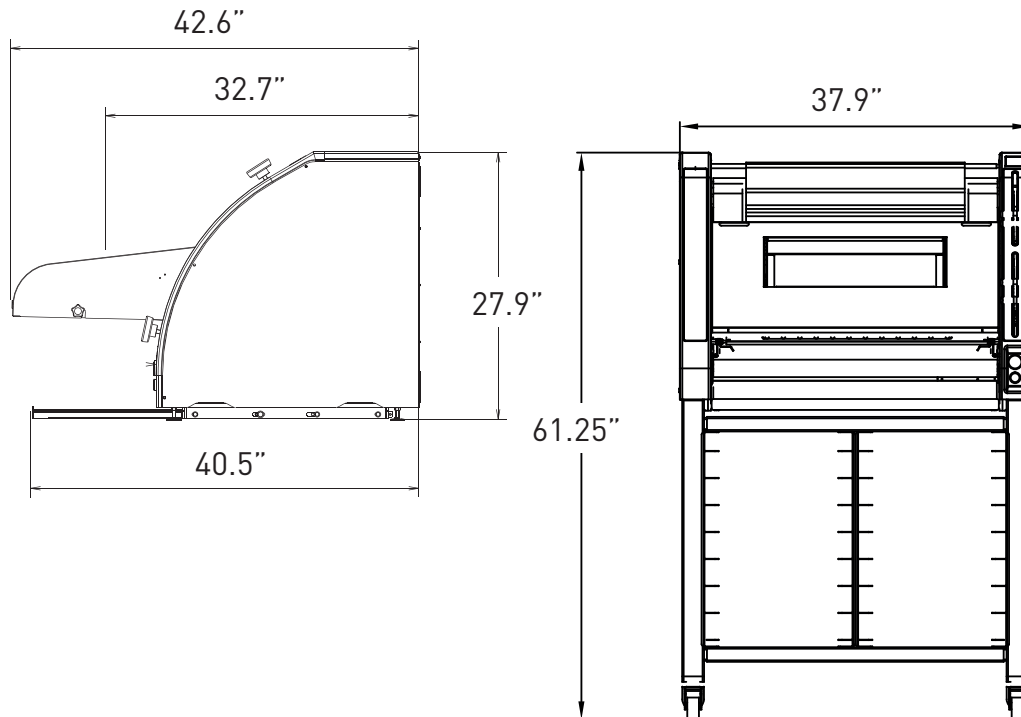

Traditionally Innovative

[www.jac-machines.com](http://www.jac-machines.com)

[office@jac-machines.com](mailto:office@jac-machines.com)



**Three food-grade polyethylene rollers**



**Retractable out-feed table**



**Adjustable rollers**  
The levers provide a high degree of accuracy and reduces the load on the wrist.



**Forming belt**  
Ultra-quick belt change without disassembling the machine.



**White board for marking product settings**

## FEATURES

	UNIC
Min/max weight of dough pieces in ounces	1.76 / 42.3 oz
Three food-grade PETP rollers	•
Maximum speed in pieces per hour	1200
Motor power in kW	1.1
Type of motor	3ph/208V/60Hz/4.8A
Belt type	Synthetic
Net weight in lbs	440

## OPTIONS

Pointed end belt	•
Outfeed guides	•
Standard wheeled base	•
Wheeled base with storage	•

## Stainless steel moulder bases

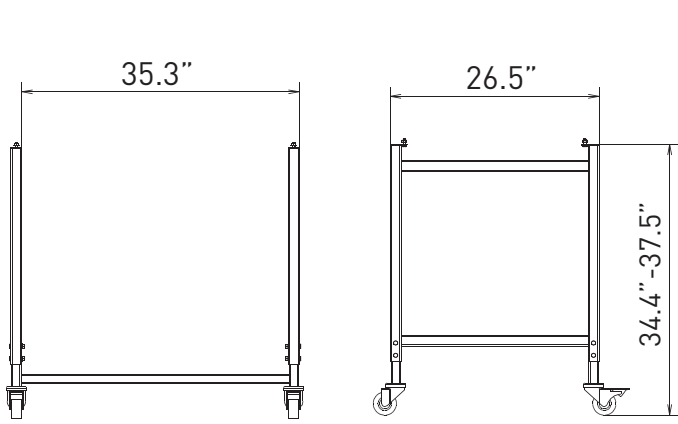

Simple base dimensions (in inches)

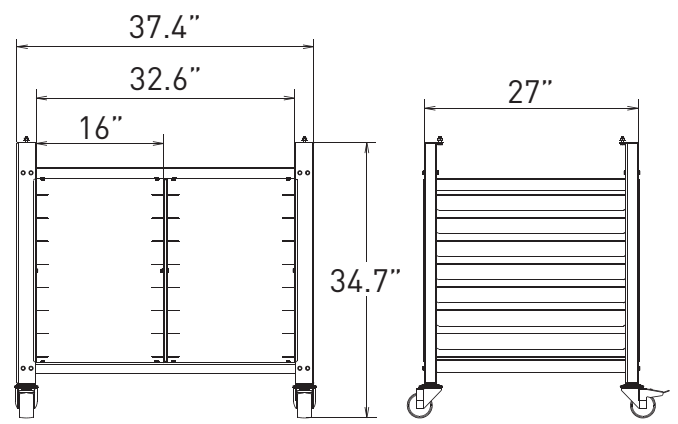

Dimensions of base with storage (in inches)



# With more than 250 partners around the world

## From specialist...

You know your business and demand the best quality for your production. Both in your bakery and in the store, you want everything to be perfect. Your production equipment is essential to you. You chose it for its performance.

It has to stand up to intensive use over time and not give the least cause for concern. In the event of problems, skilled technical department personnel can provide assistance by telephone or in person upon request.

## ... to specialist

Because service is often associated with geographical proximity, JAC has a network of 250 distributors around the world.

We take care to provide them with the technical and human support necessary, so that you can have 100% trust in JAC, whether you're in Tokyo, Paris, Dakar or Boston. Product knowledge, routine spare parts, competence and speed of response. Directly linked to the JAC repair centre, they also benefit from all the recommendations from our factories.

## Health and safety standards

All new products from JAC are subject to the most stringent health and safety checks. Our frequent meetings with international inspection bodies allow us to pre-empt future standards. When you buy JAC equipment, conformity is guaranteed.



This guarantee applies to all the parts of your machine, including electronic components but excluding wearing parts. Please do not hesitate to contact your authorised dealer today for more information.



## Servicing - Spare parts

JAC Inc. Boston  
149, River Street  
Suite#2  
Andover, MA 01810  
Tel.: + 1 781-721-2100  
Fax: + 1 781-721-2112  
office@jac-machines.com







[www.jac-machines.com](http://www.jac-machines.com)



This guarantee applies to all the parts of your machine, including electronic components but excluding wearing parts. Please do not hesitate to contact your authorised dealer today for more information.

JAC Inc. Boston  
149, River Street  
Suite#2  
Andover, MA 01810  
Tel.: + 1 781-721-2100  
Fax: + 1 781-721-2112  
office@jac-machines.com

[www.jac-machines.com](http://www.jac-machines.com)